

High Level Assembler for MVS® & VM & VSE

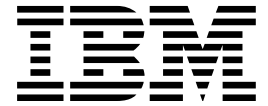

# Toolkit Feature Interactive Debug Facility User's Guide

*Release 4*



High Level Assembler for MVS® & VM & VSE

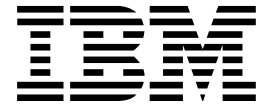

# Toolkit Feature Interactive Debug Facility User's Guide

*Release 4*

**Note!**

Before using this information and the product it supports, be sure to read the general information under "Notices" on page 276.

**Fourth Edition (September 2000)**

This edition applies to IBM High Level Assembler for MVS & VM & VSE, Release 4, Program Number 5696-234 and to any subsequent releases until otherwise indicated in new editions. Make sure you are using the correct edition for the level of the product.

Order publications through your IBM representative or the IBM branch office serving your locality. Publications are not stocked at the address below.

A form for reader's comments is provided at the back of this publication. If the form has been removed, address your comments to:

IBM Corporation, Department BWE/H3  
P.O.Box 49023  
SAN JOSE, CA 95161-9023  
United States of America

When you send information to IBM, you grant IBM a nonexclusive right to use or distribute the information in any way it believes appropriate without incurring any obligation to you.

© Copyright International Business Machines Corporation 1982, 2000. All rights reserved.

US Government Users Restricted Rights – Use, duplication or disclosure restricted by GSA ADP Schedule Contract with IBM Corp.

---

# Contents

<b>About This Book</b> . . . . .	xiii
Syntax Notation . . . . .	xiii
<b>Summary of Changes</b> . . . . .	xvi

---

## Part 1. What is IDF and How Do I Start Using It? . . . . . 1

<b>Chapter 1. Introduction to the Interactive Debug Facility</b> . . . . .	2
Capabilities . . . . .	2
Execution Control . . . . .	3
Symbol Support . . . . .	3
Typeover Storage Modification . . . . .	4
Intelligent Cursor Sensing . . . . .	4
Screen Swapping . . . . .	4
Record and Playback . . . . .	4
Customization - Profile and Macros . . . . .	5
Where Can I Run IDF? . . . . .	5
Environments Supported . . . . .	5
Limitations when Debugging on TSO . . . . .	5
Limitations when Debugging on CMS . . . . .	6
Limitations when Debugging under VSE . . . . .	7
<b>Chapter 2. Getting Started with IDF</b> . . . . .	8
Program Preparation . . . . .	8
Program Debug Basics . . . . .	8
Sample Debug Session on TSO . . . . .	9
Sample Debug Session on CMS . . . . .	9
Sample Debug Session on VSE . . . . .	10
Running IDF on Sample Program . . . . .	11

---

## Part 2. Guide to Using IDF . . . . . 13

<b>Chapter 3. Using ASMLANGX to Extract Source-Level Information</b> . . . . .	14
Assembly Requirements . . . . .	14
Program Build Requirements . . . . .	14
Running ASMLANGX . . . . .	15
Return Codes . . . . .	18
<b>Chapter 4. Invoking IDF to Debug Your Program</b> . . . . .	19
IDF Invocation . . . . .	19
IDF Options at Invocation . . . . .	20
1ADSTOP (CMS only) . . . . .	21
AMODE24   AMODE31 . . . . .	21
ASCII . . . . .	21
AUTOLOAD   NOAUTOLD . . . . .	21
AUTOSIZE   NOAUTOSZ . . . . .	22
BCX   NOBCX . . . . .	22
CKSUBCM . . . . .	22
CMDLOG . . . . .	22

CMPEXIT	23
COLORS   COLOURS	23
COMMAND	23
DMSO (CMS only)	23
EXITEXEC	24
FASTPATH   PATH   PATHFILE	24
FULLQUAL	24
HEXDISP	24
HEXINPUT	25
IMPMACRO   NOIMPMAC	25
INVPSW   NOINVPSW	25
ISA (CMS only)	25
LIBE (TSO and CMS)	25
LINE (CMS only)	26
LUNAME (VSE only)	26
LSMDEBUG	26
MACROLOG	26
MODE (CMS only)	26
MODMAP   NOMODMAP (CMS only)	27
NODSECTS	27
NUCEXT (CMS only)	27
OFFSET	27
OLDBREAK	27
PASSPGM	28
PROFILE   NOPROFIL	28
QWDUMP	28
RISK	28
RLOG	28
ROWSTYLE	29
SBORDER	29
SCDACTIV	29
SELFNUCX (CMS only)	29
STOPNOP   NOSTOPNP	29
STOPSTMT   NOSTOPST	30
SVC97   NOSVC97 (TSO only)	30
SWAP	30
SYSTEM (CMS only)	30
TRACEALL	31
TRANS (CMS only)	31
UNFTDUMP	31
Initialization of General-Purpose Registers (GPRs)	31
Initialization of Floating Point Registers	32
Initialization of Access Registers	32
The PATH, FASTPATH, and PATHFILE Options	32
Using the PATH Option	32
Using the PATHFILE Option	33
Using the FASTPATH Option	33
Excluding Called Subroutines	34
<b>Chapter 5. Debugging Programs on TSO</b>	<b>35</b>
Dataset Naming Conventions	35
Breakpoint Method Selection	35
How to Specify Parameters for Your Program	36
Loading Programs	37

Programs Requiring Environmental Setup . . . . .	39
Dynamically Loaded Programs . . . . .	39
Programs Invoked by REXX . . . . .	41
ISPF Applications . . . . .	41
DB2 Applications . . . . .	41
Causing a Break-In Event . . . . .	42
Your Program's Defined Limits . . . . .	42
Programs Performing Full-Screen I/O . . . . .	43
<b>Chapter 6. Debugging Programs on CMS . . . . .</b>	<b>44</b>
Program Preparation on CMS . . . . .	44
How to Specify Parameters for Your Program . . . . .	44
User-Area Programs . . . . .	45
CMS Transient Programs . . . . .	45
CMS Nucleus Extensions Loaded Explicitly . . . . .	46
Self-Loading CMS Nucleus Extensions . . . . .	46
Programs Requiring Environmental Setup . . . . .	47
Dynamically Loaded Programs . . . . .	48
Programs Invoked by REXX . . . . .	49
Programs Declaring Interrupt Routines . . . . .	49
Causing a Break-In Event . . . . .	50
Your Program's Defined Limits . . . . .	50
PER Versus non-PER Mode . . . . .	51
Programs Performing Full-screen I/O . . . . .	52
Using a Message-Trapping Tool . . . . .	52
<b>Chapter 7. Debugging Programs on VSE . . . . .</b>	<b>54</b>
Dataset Naming Conventions . . . . .	54
How to Specify Parameters for Your Program . . . . .	54
Loading Programs . . . . .	54
Dynamically Loaded Programs . . . . .	55
Running with Subtasks . . . . .	56
Running with CICS . . . . .	56
Debugging STXIT code . . . . .	56
Causing a Break-In Event . . . . .	57
Your Program's Defined Limits . . . . .	57
Programs Performing Full-Screen I/O . . . . .	58
<b>Chapter 8. Windows, PF Keys, Cursor Positioning, and Other Operational Details . . . . .</b>	<b>59</b>
Windows . . . . .	59
AdStops window (CMS only) . . . . .	60
Additional Floating-Point Registers window . . . . .	61
Break window . . . . .	61
Current Registers window . . . . .	62
Disassembly window . . . . .	63
Dump window . . . . .	64
LSM Information window . . . . .	66
Minimized Windows Viewer . . . . .	67
Options window . . . . .	68
Old Registers window . . . . .	68
Skipped Subroutines window . . . . .	69
Target Status window . . . . .	69
Some Examples of Actual Screens . . . . .	70

Specifying a Window . . . . .	71
PF Keys . . . . .	72
Command Record and Playback Features . . . . .	72
Address Expressions . . . . .	73
Addresses Displayed by IDF . . . . .	75
Arguments and Cursor Positioning . . . . .	75
<b>Chapter 9. Source-Level Debug Additional Capabilities . . . . .</b>	<b>78</b>
Controlling Single-stepping your Program . . . . .	79
Displaying and Changing Items . . . . .	80
Variable Expressions . . . . .	81
Variable Scope . . . . .	81
Variable Names . . . . .	81
Simple Variables . . . . .	81
Aggregate Variables . . . . .	81
Dot Qualification . . . . .	82
Based Variables . . . . .	82
Array Indexing . . . . .	82
Substrings . . . . .	83
Examples . . . . .	84
Displaying Variable Names . . . . .	84
Displaying CALLERS . . . . .	84
<b>Chapter 10. Commands and Operating Procedures . . . . .</b>	<b>85</b>
IDF Commands Cross-reference . . . . .	85
ABEND (CMS and TSO) . . . . .	88
ADSTOP (CMS only) . . . . .	88
ADSTOPS (CMS only) . . . . .	89
AFPR . . . . .	89
ALARM . . . . .	89
ALET . . . . .	90
APROGMSG (CMS only) . . . . .	90
AREGS . . . . .	91
ARRAY . . . . .	91
AUDIT . . . . .	92
BACK . . . . .	93
BASE . . . . .	93
BINARY . . . . .	93
BIT . . . . .	94
BOTTOM . . . . .	94
BREAK . . . . .	95
BRIEF . . . . .	97
CALLERS . . . . .	98
CHARACTER . . . . .	99
CHECK . . . . .	100
CLOSE . . . . .	101
COLORS . . . . .	101
COMMAND . . . . .	102
COMPACT . . . . .	102
CREGS (CMS only) . . . . .	103
CURSOR . . . . .	104
DBREAK . . . . .	104
DETAIL . . . . .	106
DISASM . . . . .	107

DOWN	108
DROP GLOBAL	108
DROP MODULE	108
DROP SYMBOLS	109
DUMP	109
DUMPMODE	110
EPOFFSET	110
EXITEXEC	110
EXLIMIT	111
FIND	111
FIRST	113
FIXED	113
FLOAT	114
FMT	114
FOLLOW	114
FORMAT	115
FPC	116
FPR	117
GLOBALS	117
GOTO	117
GPACK	118
GPR	118
GSTATUS	118
HIDE	119
HISTORY	120
ICOUNT	121
KWDSYN	121
LANGUAGE +	121
LANGUAGE COLOR	122
LANGUAGE COMMENTS	123
LANGUAGE DEBUG	123
LANGUAGE DECLARES	124
LANGUAGE DROP	124
LANGUAGE LOAD	125
LANGUAGE MACROS	127
LANGUAGE OPTIONS	128
LANGUAGE SCROLL	128
LANGUAGE STATUS	129
LANGUAGE STEM	130
LANGUAGE VERSION	130
LANGUAGE XPATH (CMS and TSO)	131
LAST	131
LASTMSG	132
LEFT	132
LIBE (CMS and TSO)	133
LOAD	134
LOCATE	137
LOCATION	137
LOCATION ALET	138
MACRO	138
MAJOR	139
MAP	139
MAXIMIZE	140
MINIMIZE	140

MODE (CMS only)	141
MODULE	141
MODULE	141
MODULE BASE	142
MODULE SIZE	143
MOVE	144
MPACK	146
MRUN	146
MRUN invoked through address ASM on CMS	147
MSG	148
MSGID (CMS and TSO)	148
MSGMODE	149
MSTATUS	150
MSTEP	150
NAMES	151
NEXT	152
OFFSET	153
OPEN	154
OPTIONS	155
ORDER	155
OREGS	156
PACKED	156
PARMS	156
PAUSE	157
PER (CMS only)	157
PFK	158
PFKDISP	158
PLOCATES	159
PRESERVE	159
PREVIOUS	160
PROGCHK (CMS only)	161
PROGCK	162
PSW	162
PSWSTEAL (CMS only)	162
QUALIFY	164
QUIT	164
QUIET	164
QUIETLY	164
QUIT	165
RCQUIT	165
REFRESH	166
REGS	167
REGSTOPS (CMS only)	167
RESTORE	167
RETRIEVE	167
RIGHT	168
RLOG	168
RUN	169
RUNEXIT	169
R0-R15	170
SALIMIT	170
SAREGS	171
SAVE	171
SEARCH	171

SELFNUCX (CMS only)	172
SET ADSTOP (CMS only)	173
SET AREG	173
SET BREAK	173
SET COMMAND	174
SET EXITEXEC	174
SET GLOBAL STEM	175
SET GLOBAL TEXT	176
SET ICOUNT	176
SET OFFSET	176
SET OPTION	177
SET PSW	178
SET REGSTOP (CMS only)	179
SET SIZE	179
SHOW	179
SIZE	181
SKIPSTEP	183
SPACE	184
STATUS	184
STEP	185
STMTSTEP	185
STOKEY	186
STOREMAP	187
STRUCTURE	187
SUBSET (CMS only)	189
SVC (CMS only)	189
SWAP	189
SYMBOL	190
TASKS (TSO only)	191
TITLE	191
TOP	192
TRIGGER LOAD	192
TYPE	193
UNION	194
UNTIL	194
UP	194
VALUE	194
VARIABLE	195
VCHANGE	196
VERSION	196
VS	197
VSEP	197
WATCH	197
WHERE	199
XEXIT (CMS only)	200
ZONED	200

---

**Part 3. Advanced Topics, Macros, Profiles, Exit Routines** . . . . . 203

<b>Chapter 11. Writing an IDF Profile</b>	204
When the PROFILE is Executed	205
Command Restrictions Related to PROFILE Execution	205

<b>Chapter 12. Writing IDF macros</b>	207
REXX Linkage Considerations	208
The REXX ADDRESS Statement	208
Initial or Default ADDRESS Environment	209
Overriding the Default ADDRESS Environment	209
Saving and Restoring an ADDRESS Environment	210
Example macros	210
<b>Chapter 13. The IDF Exit Routine</b>	214
Naming the Exit Routine	214
Controlling Exit Routine Processing	214
Passing the Reason for Invocation	214
Looking at the Address	215
Ignoring the Event	216
Other Techniques	216
Writing a Compiled-Language IDF Exit Routine	216
Specifying that an exit routine is compiled code	216
Requirements for compiled-language exit routines	217
<b>Chapter 14. REXX Variables Available to Macros</b>	219
REXX Variables with Fixed Names	219
REXX Variables with Variable Names	220
<b>Chapter 15. EXTRACT Command</b>	222
Function	222
Return Codes	222
ADSTOPS (CMS only)	222
ALET	223
AREGS	223
ARGUMENT   ARGS	223
ARRAY	224
BREAK	225
CALLERS	225
CMDMSG	226
COLORS	227
CURSOR	227
DISASM	228
EVENT	230
EXITEXEC	230
GLOBAL	230
GLOBAL STEM	230
GLOBAL STEMS	231
GSTATUS	231
ICOUNT	231
LANGUAGE ARGUMENTS   ARGS	232
LANGUAGE COMMANDS   CMDS	232
LANGUAGE OPTIONS	232
LANGUAGE STATUS	233
LANGUAGE STEM	233
LANGUAGE VERSION	234
LASTMSG	234
LOAD	235
LOCATION	235
LOCATION ALET	236

MAP	236
MODE (CMS only)	237
MODULES	237
MSTATUS	238
NAMES	238
OPTIONS	239
PER (CMS only)	239
PFK	239
PLIST	240
PLOCATES	240
QUALIFY	240
QUERY SETTING	241
REGS	241
REGSTOPS (CMS only)	242
SCOPE	242
SCRVAR	242
SELFNUCX	243
SKIPSTEP	243
SOURCE	244
STOREMAP	244
STRUCTURE	245
SVC (CMS only)	245
SYMBOLS	245
TASKS	247
TYPE	247
UNION	248
VALUE	248
VARIABLE	248
VDECLARE   VDCL	249
VERSION	249
VLOC	250
VVALUE	250
WINDOWS	251
<b>Appendix A. ASMLANGX Options</b>	<b>252</b>
ASM	252
CONDASM   NOCONDASM	252
DCL   NODCL	252
DEBUG	252
ERROR	252
INCL   NOINCL	253
IFM (CMS only)	253
LOUD   QUIET	253
MACDEF   NOMACDEF	254
OFM (CMS only)	254
OFN	254
OFT	254
PACK   NOPACK	254
PFM (CMS only)	255
PFT	255
SEQ   NOSEQ	255
<b>Appendix B. Diagnostic Messages</b>	<b>256</b>
Message Numbers and Severity Levels	256

ASMLKEDT Messages (VSE only)	257
IDF Language Support Messages	257
IDF Base Debugger Messages	260
ADATA Extraction Utility Messages	267
<b>Appendix C. Abbreviations</b>	<b>272</b>
<b>Appendix D. Performance Considerations</b>	<b>273</b>
<b>Appendix E. Migrating from TSO/E TEST to IDF</b>	<b>274</b>
General Considerations	274
Invoking the target program	274
Specifying the target program parameters	275
<b>Notices</b>	<b>276</b>
Trademarks	277
<b>Glossary</b>	<b>278</b>
<b>Bibliography</b>	<b>285</b>
High Level Assembler Publications	285
Toolkit Feature Publications	285
Related Publications (Architecture)	285
Related Publications for MVS	285
Related Publications for VM	286
Related Publications for VSE	286
General Publications	286
<b>Index</b>	<b>287</b>

---

## About This Book



This book provides information on how to use the High Level Assembler Toolkit Feature Interactive Debug Facility (IDF).

Throughout this book, we use these indicators to identify platform-specific information:

- Prefix the text with platform-specific text (for example, “Under CMS...”)
- Add parenthetical qualifications (for example, “(CMS only)”)
- Bracket the text with icons. The following are some of the icons that we use:

 Informs you of information specific to MVS 

 Informs you of information specific to CMS 

 Informs you of information specific to VSE 

MVS is used in this manual to refer to Multiple Virtual Storage/Enterprise Systems Architecture (MVS/ESA™) and to OS/390®.

CMS is used in this manual to refer to Conversational Monitor System on Virtual Machine/Enterprise Systems Architecture (VM/ESA®).

VSE is used in this manual to refer to Virtual Storage Extended/Enterprise Systems Architecture (VSE/ESA®).

---

## Syntax Notation

Throughout this book, syntax descriptions use the structure defined below.



- Read the syntax diagrams from left to right, from top to bottom, following the path of the line.

The  symbol indicates the beginning of a statement.

The  symbol indicates that the statement syntax is continued on the next line.

The  symbol indicates that a statement is continued from the previous line.

The  symbol indicates the end of a statement.

Diagrams of syntactical units other than complete statements start with the  symbol and end with the  symbol.

- **Keywords** appear in uppercase letters (for example, ASPACE) or upper and lower case (for example, PATHFile). They must be spelled exactly as shown. Lower case letters are optional (for example, you could enter the PATHFile keyword as PATHF, PATHFI, PATHFIL or PATHFILE).

**Variables** appear in all lowercase letters in a special typeface (for example, *integer*). They represent user-supplied names or values.

- If punctuation marks, parentheses, or such symbols are shown, they must be entered as part of the syntax.
- Required items appear on the horizontal line (the main path).

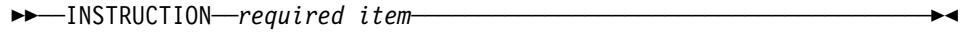

- Optional items appear below the main path. If the item is optional and is the default, the item appears above the main path.

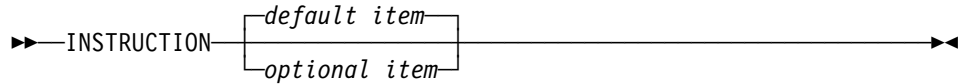

- When you can choose from two or more items, they appear vertically in a stack.

If you **must** choose one of the items, one item of the stack appears on the main path.

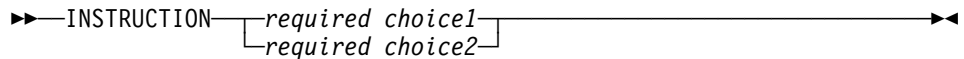

If choosing one of the items is optional, the whole stack appears below the main path.

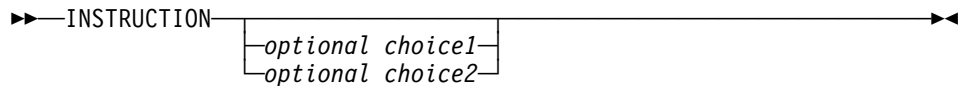

- An arrow returning to the left above the main line indicates an item that can be repeated. When the repeat arrow contains a separator character, such as a comma, you must separate items with the separator character.

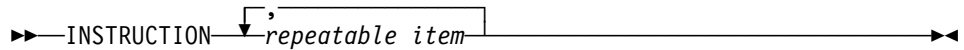

A repeat arrow above a stack indicates that you can make more than one choice from the stacked items, or repeat a single choice.

The following example shows how the syntax is used.

**Format**

**A**                      **B**                      **C**

►►—*optional item*—INSTRUCTION—  
   *1*—  
   *operand choice1*  
   *operand choice2*<sup>(1)</sup>  
   *operand choice3*

**1** :  
 |  
 |  
 |

**Note:**  
<sup>1</sup> *operand choice2* and *operand choice3* must not be specified together

- A** The item is optional, and can be coded or not.
- B** The INSTRUCTION key word must be specified and coded as shown.

- C** The item referred to by **1** is a required operand. Allowable choices for this operand are given in the fragment of the syntax diagram shown below **1** at the bottom of the diagram. The operand can also be repeated. That is, more than one choice can be specified, with each choice separated by a comma.

---

## Summary of Changes

This manual has been reorganized in response to user requests.

---

## **Part 1. What is IDF and How Do I Start Using It?**

<b>Chapter 1. Introduction to the Interactive Debug Facility . . . . .</b>	<b>2</b>
<b>Chapter 2. Getting Started with IDF . . . . .</b>	<b>8</b>

---

## Chapter 1. Introduction to the Interactive Debug Facility

The Interactive Debug Facility (IDF) is a symbolic debugging tool for Assembler Language programs. You can also use it to debug programs written in compiled languages, at the object code level.

The *Language Support Module* (LSM) functions provide for debugging Assembler Language programs at the source level. The ASMLANGX utility reads the ADATA file, produced by the High Level Assembler when you assembled your program, and builds a file that IDF can use for source-level debugging.

You do not have to learn a new command language to use IDF. All IDF's basic functions can be performed by using the default PF keys.

IDF is window oriented. The screen can be filled with windows of various types, including:

- Current Registers window
- Disassembly window
- Dump window
- LSM Information window

Windows can be mixed and matched in any order or combination on the screen. You can open multiple:

- Dump windows to view multiple areas of non-contiguous storage
- LSM Information windows
- Disassembly windows to view and modify your program at the object code level

These windows will show the source statements if they are available.

In general, the command that opens the window (for example, REGS for Current Registers) is used to close that window on the screen.

---

### Capabilities

IDF can be used for disassembly-level (object code level) or source-level debugging of user programs under TSO, CMS and VSE.

- On TSO
  - Programs can be “batch” or TSO Command Processors, with support provided for reentrant modules.
  - IDF provides for debugging programs (for example, ISPF programs) for which some environmental setup is needed.
  - Parameters are passed to your program using standard MVS\* EXEC PGM or TSO Command Processor linkage conventions.
- On CMS
  - Programs can be a mix of user-area programs, transients, nucleus extensions, and self-relocating nucleus extensions.
  - Unless one of the debugged programs is a transient, CMS SUBSET is available throughout the debugging session.

- IDF provides for debugging programs (for example, a REXX function package) for which some environmental setup is needed.
- Parameters are passed to your program using standard CMS linkage conventions, with both tokenized and untokenized lists.
- On VSE
  - Parameters are passed to your program using standard VSE EXEC PGM linkage.

The following sections provide an overview of IDF's capabilities.

## Execution Control

You can single-step through a program. If a Disassembly window is open as the program progresses, the next instruction to be executed is highlighted.

You can use exit routines, written in REXX or compiled languages, to examine conditions surrounding a breakpoint and determine whether or not to inform you of its occurrence, or to ignore the breakpoint and continue execution.

By using the PATH option you can capture the number of times each instruction in your program is executed. This can be helpful in locating "dead code".

You can use the HISTORY command to review the last 1,023 machine instructions executed by your program. This is often useful in determining the circumstances leading to a "wild branch" or similar error.

An exit routine can use the MSTEP command to perform a dynamic path analysis of your program. (This analysis is slow, since part of a REXX exit routine is executed for each instruction your program executes.)

**CMS** If Extended Control (EC) mode is available to IDF, PER is used to provide register or storage alteration stops. Breakpoints and single-step mode are available regardless of EC mode availability.

All SVC instructions issued by your program can be trapped.

If your program invokes a nucleus extension through BALR linkage, an option lets you single-step through that nucleus extension.

IDF can debug programs that "steal" the new PSWs, if your program's instructions which access these PSWs are declared to IDF. **CMS**

## Symbol Support

You get symbol support by assembling with the ADATA option and using ASMLANGX to create an extraction file from the SYSADATA file.

This allows you to enter instruction and data addresses in symbolic notation, and show data areas with their associated labels, or in an unformatted display.

IDF provides a disassembly capability, with code section (CSECT) and external symbols intensified. Storage references are disassembled to their symbolic names wherever possible.

## Capabilities

Conditional branch instructions are disassembled to their extended mnemonics unless you specify otherwise.

### Typeover Storage Modification

When a Dump window is open or when a Disassembly window contains storage being dumped, you can change locations by positioning the cursor to the desired area and typing over the contents; you can do this in either the hex or character area of the display.

If the Current Registers window is displayed, you can alter the PSW, general purpose registers, and floating point registers in the same way.

When a Disassembly window is open, you can modify the hex values of the instructions by typing over them. These changes are immediately reflected on the screen with different instruction mnemonics, addresses, and so on.



### Intelligent Cursor Sensing

When the Current Registers window is open, you can display the area of storage addressed by a general purpose register by placing the cursor in the register and pressing the correct PF key. Similarly, you can display storage addressed by the instruction address of the PSW. If the cursor is in an access register, commands that can use an *access-list-entry token* (ALET) use the contents of the access register in addition to the contents of the associated general purpose register.

The same things can be done in the Old Registers window as in the Current Registers window.

When a Dump window is open or when the Disassembly window contains storage being dumped, a full word memory location may be used to specify the next area to be displayed by positioning the cursor in it and pressing a PF key. This is useful for following a chain of control blocks.

When a Disassembly window is open, you can set breakpoints by positioning the cursor on the desired instruction and pressing a PF key.

 When a Dump window is open or when the Disassembly window contains storage being dumped, you can set PER address (storage alteration) stops by positioning the cursor on the desired location and issuing an ADSTOP command. 

### Screen Swapping

IDF provides a screen swapping facility for debugging programs that perform full-screen I/O. When you use this facility, your program's screen is captured when a breakpoint is reached, and restored when control is returned to your program for more than a single instruction.

### Record and Playback

The IDF command record and playback facility makes recreating debugging sessions easier.

## Customization - Profile and Macros

You can use a profile, written in the REXX programming language, to redefine display colors, PF key functions, initial display format, and many other options.

A subcommand environment supports IDF macros written in REXX. The ENTER key or any of the 24 PF keys can be assigned to run a macro or an IDF command.

User-written macros can:

- extract an argument based on cursor position
- set the cursor into a given window
- set data into either of IDF's message areas
- place data on the command line
- sound the terminal's audible alarm
- obtain the disassembled text associated with an instruction

---

## Where Can I Run IDF?

IDF can be run on most ESA/370, or later, processors, from terminals (or emulators) of the 3270 family (or equivalents).

## Environments Supported

IDF runs on the operating systems listed below, and unless otherwise stated, on subsequent versions, releases, and modification levels of these systems:

### TSO

MVS SP Version 5 Release 1  
OS/390 Version 1

**Note:** TSO/E Version 2 or higher is required to use IDF's macro capabilities.

DFSMS/MVS 1.3 is required to access PDSE datasets.

### CMS

VM/ESA Release 2

### VSE

VSE/ESA Release 2.3

## Limitations when Debugging on TSO

The following limitations apply on TSO:

- IDF can only be used to debug programs that have their own (E)SPIE or (E)STAE exits if SVC 97 is used for breakpoints. The default is to use SVC 97 for breakpoints. You can override this by using the NOSVC97 option, or a SET OPTION ON NOSVC97 command in the PROFILE macro. For more details see "Breakpoint Method Selection" on page 35.
- IDF cannot debug programs that issue ISPF SELECT service calls or those that involve MVS multitasking *unless* SVC 97 is used for breakpoints. The default and override are as for the previous point.

## Limitations

- The REXX system interface requires that external functions return an EVALBLOK. If you are debugging a REXX function package that has been called by a REXX exec and you quit from IDF before the function has completed, the REXX interpreter issues an error message. You may need to logoff TSO and log back on.

## Limitations when Debugging on CMS

The following limitations apply on CMS:

- You must take special care when debugging programs which:
  - Employ interrupt-driven exit routines, such as ABNEXIT or HNDEXT exit routines
  - Reside above the address contained in the VMSIZE word of NUCON
  - Reside in DCSS, whether read only or read-write
- The REXX system interface requires that external functions return an EVALBLOK. If you are debugging a REXX function package that has been called by a REXX exec and you quit from IDF before the function has completed, the REXX interpreter issues an error message. You may need to re-IPL CMS.
- An IDF macro should invoke MRUN or MSTEP (or any other IDF command which causes immediate execution of the target program) using the LPSW Fastpath REXX addressing environment, which is the default addressing on entry to IDF macros. Detailed usage notes under “MRUN” on page 146 indicate the limitations of and effects of using Address ASM.
- If you use IDF's PER Y mode to debug your program, IDF uses the hardware Program Event Recording (PER) support for register and storage alteration events.

PER events might be triggered during the execution of CMS's SVC handling (for example, for a register alteration). If the event occurs in the small window between the start of that CMS SVC handling and the point where it has saved the SVC interrupt status, there is a problem if IDF tries to issue an SVC itself (for example, to obtain working storage or to display a full-screen panel). CMS would recognize an illegal SVC recursion, issue a message, and require a re-IPL.

IDF uses special logic when running on CMS level 8 (or higher) to detect when CMS is in that small window of its SVC handler; if you are on CMS 7 (or lower), the IDF detection logic is bypassed. CMS may detect an *illegal reentry into INTSVC*, and require a re-IPL of CMS.

Because IDF cannot issue an SVC itself when in the *SVC window*, it cannot display a full-screen panel, or even issue a normal LINEDIT or LINEWRT or WRTERM (which each require an SVC). Instead, it generates a set of CP MSG \* messages to the terminal to provide some basic information about the event that could not be handled normally. IDF execution continues normally after these messages.

## **Limitations when Debugging under VSE**

The following limitations apply on VSE:

- IDF only supports debugging of phases that are loaded into the same partition as IDF.
- Logical Transients or phases loaded into the SVA cannot be debugged
- The VSE Linkage Editor does not include any SYM records in the phase. Therefore only external symbols are available for IDF processing on VSE, unless you use the source level facilities provided by ASMLANGX, see “Batch Language Extraction on VSE” on page 17.

---

## Chapter 2. Getting Started with IDF

This chapter provides a description of the steps to debug the IDF sample program.

IDF needs some changes to your normal run-time environment to allow it to debug your programs. These changes ensure that IDF receives and retains control when your program runs.

---

### Program Preparation

Before invoking IDF, you need to make some information about your program available to IDF.

In any case where IDF's source-level debug capabilities are used, before a debugging session you must generate an IDF language extract file, using the ASMLANGX utility.

Detailed information about program preparation is provided in Chapter 3, "Using ASMLANGX to Extract Source-Level Information" on page 14.

---

### Program Debug Basics

Having prepared your program, you can use IDF to help you debug it.

A typical sequence of operations is:

- Start the debugging session by invoking ASMIDF (IDF), specifying your program name, IDF options (if appropriate), and parameters to pass to your program.
- Issue the LANGUAGE LOAD command to load the IDF Language extract files for all other program sections which are relevant to the problem being debugged.
- Issue IDF commands to tailor your debugging environment and to determine where your program is in error. You can issue commands as IDF macros, or interactively at the command prompt.

Commands to IDF come from:

- Entering them on the IDF command line.
- Pressing PF keys, which issues the associated IDF command.

The IDF commands on PF keys are the default set of commands provided by IDF, or user commands, registered using the PFK command.

- IDF macros (written in REXX).
- User programs.

Refer to Chapter 8, "Windows, PF Keys, Cursor Positioning, and Other Operational Details" on page 59 and Chapter 10, "Commands and Operating Procedures" on page 85 for more details.

---

## Sample Debug Session on TSO

This section provides a simple example of preparing and debugging an assembler language program. It assumes that both the High Level Assembler and the IDF components of the Toolkit were installed on your system and you have access to them.

### Sample Program Preparation

1. Assemble and link the sample program:

```
//jobname JOB
//ASMMMSAMP EXEC ASMACL,PARM.C=(OBJ,ADATA)
//C.SYSIN DD DSN=<hlq>.SASMSAM2(ASMMMSAMP),DISP=SHR
//C.SYSADATA DD DSN=<myid>.SYSADATA(ASMMMSAMP),DISP=SHR
//L.SYSLMOD DD DSN=<myid>.LOAD(ASMMMSAMP),DISP=SHR
```

2. Create the source-level extract file:

```
//jobname JOB
//ASMMMSAMP EXEC PGM=ASMLANGX,PARM='ASMMMSAMP'
//SYSADATA DD DSN=<myid>.SYSADATA,DISP=SHR
//ASMLANGX DD DSN=<myid>.ASMLANGX,DISP=SHR
```

### Invoking IDF

At the TSO/E READY prompt allocate the required datasets:

```
ALLOC FI (ASMLANGX) DS('<myid>.ASMLANGX') SHR
TSOLIB ACT DS('<myid>.LOAD')
```

Invoke IDF by entering:

```
ASMIDF ASMMMSAMP
```

Wait until the initial IDF panel is displayed, and then continue at “Running IDF on Sample Program” on page 11.

---

## Sample Debug Session on CMS

This section provides a simple example of preparing and debugging an assembler language program. It assumes that both the High Level Assembler and the IDF components of the Toolkit were installed on your system and you have access to them.

### Sample Program Preparation

1. Assemble the sample program:

```
ASMAHL ASMMMSAMP (ADATA)
```

2. Generate the load module and rename the LOAD MAP file:

```
LOAD ASMMMSAMP (RLDSAVE
GENMOD ASMMMSAMP
RENAME LOAD MAP A ASMMMSAMP = =
```

3. Create the source-level extract file:

```
ASMLANGX ASMMMSAMP
```

### Invoking IDF

Invoke IDF by entering:

```
ASMIDF ASMMSAMP
```

Wait until the initial IDF panel is displayed, and then continue at “Running IDF on Sample Program” on page 11.

---

## Sample Debug Session on VSE

This section provides a simple example of preparing and debugging an assembler language program. It assumes that both the High Level Assembler and the IDF components of the Toolkit were installed on your system and you have access to them.

### Sample Program Preparation

```
* $$ JOB JNM=ASMMSAMP,CLASS=0,DISP=L,LDEST=*,PDEST=*
// JOB ASMMSAMP
// LIBDEF *,SEARCH=(PRD2.PROD,yourlib.sublib)
// DLBL SYSADAT,'SYSADATA',0,VSAM,                                X
        CAT=VESPUC,RECSIZE=8192,                                X
        DISP=(,KEEP),RECORDS=(500,500)
// LIBDEF PHASE,CATALOG=yourlib.sublib
// OPTION NODECK,CATAL
    PHASE ASMMSAMP,*
// EXEC ASMA90,SIZE=ASMA90,PARM='ADATA'
COPY ASMMSAMP
/*
// EXEC ASMLKEDT
/*
// EXEC ASMLANGX,PARM='ASMMSAMP'
/*
/&
* $$ EOJ
```

### Invoking IDF

Invoke IDF by running:

```
* $$ JOB JNM=ASMMSAMP,CLASS=0,DISP=L,LDEST=*,PDEST=*
// JOB ASMMSAMP
// SETPFIX LIMIT=24K
// LIBDEF *,SEARCH=(PRD2.PROD,yourlib.sublib)
// EXEC ASMIDF,PARM='ASMMSAMP (LU luname)'
/*
/&
* $$ EOJ
```

Wait until the initial IDF panel is displayed on *luname*, and then continue at “Running IDF on Sample Program” on page 11.

---

## Running IDF on Sample Program

1. Open Current Registers window by pressing PF2.

The Current Registers window shows the PSW, 16 general purpose registers and 4 floating point registers.

2. Open Disassembly window by pressing PF9.

The Disassembly window shows the sample program in object and disassembled forms.

3. Execute the first instruction by pressing PF1. This will cause IDF to automatically load the language extract file for source-level debugging.

4. Open windows to display source variables:

- open var vpacked
- open var vhalf
- open var vfull
- open var vchar

**Tip:** Use PF12 to retrieve the previous command and then overwrite the last few characters.

5. Press PF1 until end of program, observing the changing values in the Current Registers window, and values being set in storage as displayed in the LSM Variable Information windows.
6. Press PF3 twice to exit IDF.

## Getting Started

---

## Part 2. Guide to Using IDF

Chapter 3. Using ASMLANGX to Extract Source-Level Information . . . . .	14
Chapter 4. Invoking IDF to Debug Your Program . . . . .	19
Chapter 5. Debugging Programs on TSO . . . . .	35
Chapter 6. Debugging Programs on CMS . . . . .	44
Chapter 7. Debugging Programs on VSE . . . . .	54
Chapter 8. Windows, PF Keys, Cursor Positioning, and Other Operational Details . . . . .	59
Chapter 9. Source-Level Debug Additional Capabilities . . . . .	78
Chapter 10. Commands and Operating Procedures . . . . .	85

---

## Chapter 3. Using ASMLANGX to Extract Source-Level Information

Source-level debug support extends IDF by adding source code and variable display.

ASMLANGX collects information about the program sections in the program being debugged, from the SYSADAT(A) file created by the High Level Assembler.

---

### Assembly Requirements

The first step is to assemble the program.

The ADATA assembler option is *needed* to generate a file containing detailed information about the assembly.

---

### Program Build Requirements

The next step is to build the executable module, as appropriate for the operating system environment in which you intend to run IDF.

#### Building a Module on TSO

IDF uses information from the Load Module file to determine locations of the program CSECTs and external symbols.

- If both the assembler TEST option and the linkage editor TEST option are specified, the Load Module file also contain records that describe many of the assembler internal symbols. If present, IDF uses these records to help disassemble the program. They are not essential and tend to make the final Load Module file quite large. If you prefer to suppress them, omit the linkage editor TEST option or specify the NOTEST option.

The Linkage Editor Test option increases Load Module size, so do not use it for production modules.

#### Building a Module on CMS

The LOAD MAP file that results from the LOAD/GENMOD operation must be retained.

- Rename this file so that its name matches the file name of the executable module.
- This file is used by IDF to determine locations of the program CSECTs and external symbols.
- If the assembler TEST option is specified, this file also contains records that describe many of the assembler internal symbols. If present, IDF uses these records to help in the disassembly of the program. Since they are not essential, and tend to make the final MAP file quite large, you may suppress them by specifying the LOAD NOINV option.

## Building a Phase on VSE

IDF uses the librarian member `phasename.MAP` created by `ASMLKEDT`, which is a linkage editor *front-end* program.

- This member is used by IDF to determine locations of the program CSECTs and external symbols.
- The assembler `TEST` option does not apply.

If IDF cannot locate a `MAP` for a referenced phase then a dummy map is created. The dummy map has one CSECT with the same name as the phase and one entry point name **ENTRY**.

To produce a map for IDF on VSE, replace the program `LNKEDT` in the link-edit step with program `ASMLKEDT`. `ASMLKEDT` calls the linkage editor and produces a librarian member `phasename.MAP` on the `PHASE` catalog library.

To invoke `ASMLKEDT`, adjust the `JCL`, replacing

```
// EXEC LNKEDT,PARM='...'
```

with

```
// EXEC ASMLKEDT,PARM='...'
```

The `PARM` values remain the same.

For example:

```
// LIBDEF PHASE,CATALOG=MY.SUBLIB
// LIBDEF *,SEARCH=(MY.SUBLIB,...)
// OPTION CATAL
   PHASE MYPROG,*
   INCLUDE MYPROG
/*
* Invoke linkage editor and create MYPROG.MAP
// EXEC ASMLKEDT,PARM='AMODE=24'
/*
```

---

## Running ASMLANGX

The following sections describe how to run `ASMLANGX` to create a file to allow source-level debugging.

`ASMLANGX` handles the case where several programs are included in a single source file and the assembler `BATCH` option is used to process this composite program.

For all operating systems, the input file must be a `SYSADATA` file created by High Level Assembler Release 2 or higher.

### Extraction File Allocation on MVS

You may use `ASMLANGX` to create the extract files as sequential files on `MVS`, but normally you create a `PDS` to contain the extracted data for actually debugging the target program using IDF's Language Support.

The recommended format of the extract file is:

```
RECFM(VB) LRECL(1562) BLKSIZE(27998)
```

Memory above the 16MB line is exploited for extract information.

ASMLANGX does not perform any dynamic allocation. You will need to allocate the SYSADATA dataset to DDname SYSADATA and the ASMLANGX dataset to DDNAME ASMLANGX before you invoke the ASMLANGX command processor.

### Online Language Extraction on TSO

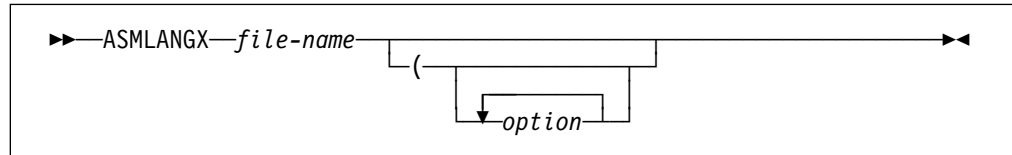

*file-name*

The PDS member name of the input and output files.

For TSO sequential files (DSORG(PS)), the name is ignored.

The default input file DDname is SYSADATA. Please see “PFT” on page 255.

The default output file DDname is ASMLANGX. Please see “OFT” on page 254.

*option*

Options are described in Appendix A, “ASMLANGX Options” on page 252.

Example TSO commands:

```
alloc dd(sysadata) ds(my.adata) shr
alloc dd(asmlangx) ds(my.langx) old
asmlangx myprog (asm loud error
```

### Batch Language Extraction on MVS

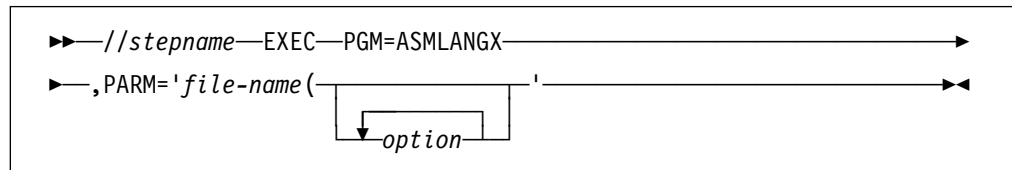

*file-name*

The PDS member name of the input and output files.

For TSO sequential files (DSORG(PS)), the name is ignored.

The default input file DDname is SYSADATA. Please see “PFT” on page 255.

The default output file DDname is ASMLANGX. Please see “OFT” on page 254.

*options*

Options are described in Appendix A, “ASMLANGX Options” on page 252.

Example JCL:

```

/*
/*      --ASMLANGX -- EXTRACTION --
/*
/*      Replace member with the correct member name
/*      Replace hlq. with the correct high-level qualifiers
/*
/*ASMLANGX EXEC PGM=ASMLANGX,REGION=4096K,
/* PARM='member (ASM LOUD ERROR'
/*SYSADATA DD  DISP=SHR,DSN=hlq.SYSADATA
/*ASMLANGX DD  DISP=OLD,DSN=hlq.ASMLANGX

```

## Online Language Extraction on CMS

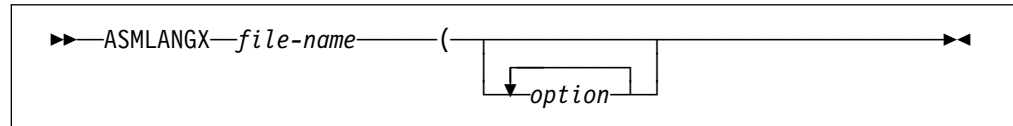

### *file-name*

The file name (FN) of the input and output files.

The default input file type is SYSADATA. Please see “PFT” on page 255.

The default output file type is ASMLANGX. Please see “OFT” on page 254.

### *option*

Options are described in Appendix A, “ASMLANGX Options” on page 252.

## Batch Language Extraction on VSE

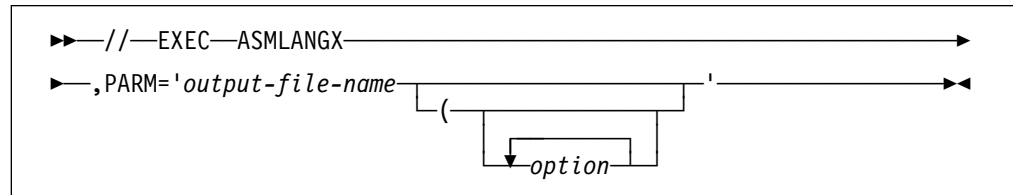

### *output-file-name*

The librarian member name of the ASMLANGX member that is either created or replaced on the specified PHASE CATALOG library.

The default input file DLBL name is SYSADAT. Please see “PFT” on page 255.

The default output file name can be overridden. Please see “OFN” on page 254.

### *option*

Options are described in Appendix A, “ASMLANGX Options” on page 252.

JCL example:

```
* Create language member ASMSAMP.ASMLANGX on MY.LIB
* for source level debug
// LIBDEF *,SEARCH ...
// LIBDEF *,CATALOG=MY.LIB <===== Required
// DLBL SYSADAT,'my.adata',0,VSAM,CAT=VSESPUC,DISP=(,KEEP)
// EXEC ASMLANGX,PARM='myprog (ASM LOUD ERROR'
/*
```

### Which Files to Keep

Once you have generated an extraction file, you can choose to discard or keep the input files. IDF needs only the extraction file and the module file, and the LOAD MAP on CMS.

**CMS, MVS** If you have several separately compiled programs which are linked into a single module, you can either retain an extraction file for each of them, or you can copy them into a single appended file for convenience. It is recommended you keep them separate, in case you want to change and recompile one of the separate compiles. **CMS, MVS**

---

## Return Codes

<b>0</b>	Operation successful, output file was written.
<b>0xxx</b>	Error discovered while parsing arguments or options, values for xxx are:
<b>1</b>	token too long
<b>2</b>	left parenthesis found inside options
<b>3</b>	unknown option
<b>4</b>	no primary input file name (PDS member name) was specified
<b>2xxx</b>	Error occurred during scan of ADATA file.
<b>3xxx</b>	Error occurred while writing output file.

For return codes 2xxx, and 3xxx, the values for xxx are:

<b>0yy</b>	yy is the RC from File_Write
<b>1yy</b>	yy is the RC from File_Open
<b>2yy</b>	yy is the RC from File_Read
<b>3yy</b>	yy is one of the following ASMLANGX codes: 10 = file not in expected format
<b>4yy</b>	yy is the RC from File_Point
<b>5yy</b>	yy is the RC from Mem_Allocate
<b>6yy</b>	yy is the RC from Mem_Free
<b>7yy</b>	yy is the RC from File_Close
<b>8yy</b>	yy is the RC from File_Note

## Chapter 4. Invoking IDF to Debug Your Program

This chapter describes how to invoke IDF to debug your program.

When preparing to use IDF, you should understand:

- How the program is packaged
- How the program is to be loaded into storage
- The conventions used to pass parameters to the program

This section explains how to invoke IDF to perform different kinds of debugging jobs.

For a complete list of options, see “IDF Options at Invocation” on page 20.

When you invoke IDF, double-check that your options are correct. If you make mistakes setting up a debugging session, you are making the session more complicated.

### IDF Invocation

#### Running IDF on TSO and CMS

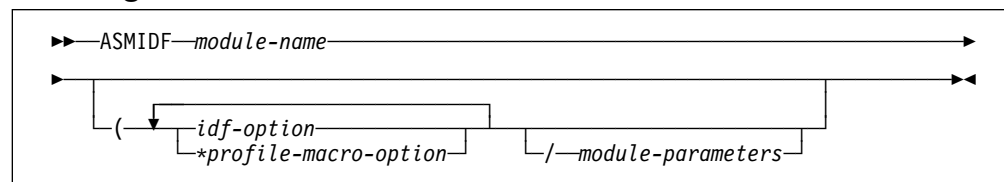

#### *module-name*

The name of the module to be debugged.

#### *idf-option*

An option directed to IDF.

See “IDF Options at Invocation” on page 20 for details on the options.

#### *\*profile-macro-option*

An option that begins with an asterisk (\*) is not examined by IDF. Instead, it is made available for processing by the PROFILE macro. Retrieve these options by issuing the EXTRACT PLIST command within the macro and parsing the result.

#### *module-parameters*

Parameters directed to the module that is to be debugged.

IDF only operates as a TSO command processor on a 3270 terminal, either real or emulated.

## Running IDF on VSE

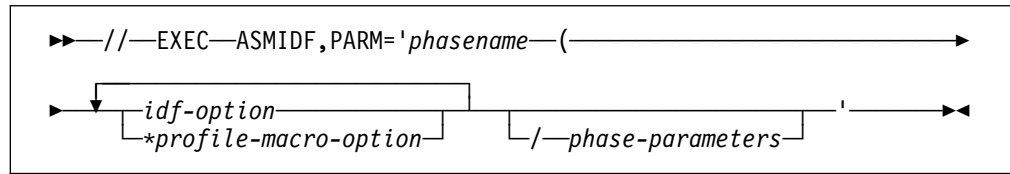

### *phasename*

The name of the phase to be debugged.

### *idf-option*

An option directed to IDF.

See “IDF Options at Invocation” for details on the options.

The LUNAME option is *required*.

### *\*profile-macro-option*

An option that begins with an asterisk (\*) is not examined by IDF. Instead, it is made available for processing by the PROFILE macro. Retrieve these options by issuing the EXTRACT PLIST command within the macro and parsing the result.

### *phase-parameters*

Parameters directed to the phase that is to be debugged.

Example JCL:

```

// SETPFIX LIMIT=24K
// LIBDEF PHASE,SEARCH=(MY.LIBRARY,HLASM.LIBRARY)
// LIBDEF PROC,SEARCH=(MY.PROCLIB,HLASM.LIBRARY)
// EXEC ASMIDF,PARM='MYPROG (LU MYterm /phase-parameters'
/*
  
```

These JCL statements are needed:

**SETPFIX LIMIT** Sets the page fix limit. This must be set to 24K for the product exit to function correctly.

**LIBDEF PHASE** Defines the library that contains the phase map created with the ASMLKEDT, or the dummy map, and the phase to be debugged.

**LIBDEF PROC** Defines the procedure library which contains any REXX macros.

**EXEC ASMIDF** Executes the program ASMIDF (IDF) using the parameters specified with the PARM option.

---

## IDF Options at Invocation

| You can set most of these options after invocation using the SET OPTION  
 | command (see “SET OPTION” on page 177). However some options only make  
 | sense if they are specified at invocation and the descriptions below will indicate  
 | those options.

## 1ADSTOP (CMS only)

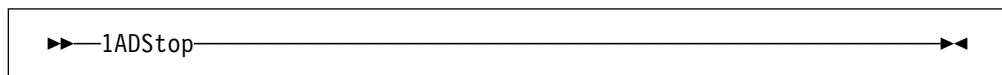

When PER is enabled, four address ranges are provided and storage modifications in any of these ranges should cause IDF to present a message. Because of the way the PER hardware works, IDF must partially disassemble the instruction being executed to obtain an address to check against the address ranges. In some cases storage modification events are missed.

However, if the 1ADSTOP option is set, the four address ranges are treated as a single address range, beginning at the lowest address in any range and ending at the highest address in any range. In this case events are recognized without partial disassembly.

## AMODE24 | AMODE31

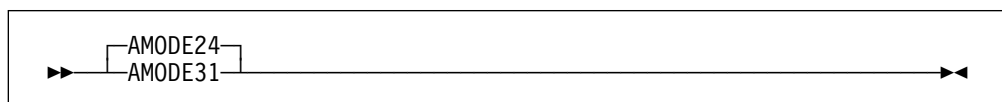

AMODE24 is valid on any XA or ESA system. It initializes the target program as AMODE-24, regardless of the CMS, MVS, or VSE defaults.

AMODE31 is also valid on any XA or ESA system. It initializes the target program as AMODE-31, regardless of the CMS, MVS, or VSE defaults.

**Note:** On CMS, if the target program is *not* a nucleus extension, and is AMODE-ANY, this option is needed to enable IDF to recognize the program as AMODE-31.

## ASCII

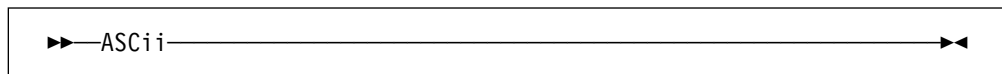

ASCII tells IDF to display the character portion of dumped storage in ASCII rather than in EBCDIC. Data overtyped in these areas is also in ASCII, rather than EBCDIC.

## AUTOLOAD | NOAUTOLD

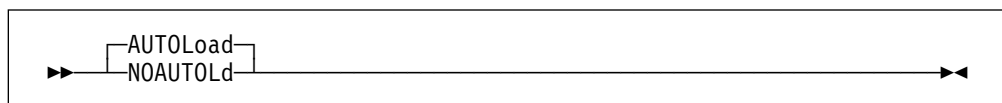

AUTOLOAD tells IDF to issue LANGUAGE LOAD commands for you if you STMTSTEP to a location that is not within a code section for which IDF Language extract data was loaded. This is done in an attempt to automatically load IDF Language extract files for you. **This only works if the code section name matches the file name of the extract file.**

NOAUTOLD tells IDF not to issue LANGUAGE LOAD commands for you if you STMTSTEP to a location that is not within a code section for which IDF Language

## Running IDF

extract data was loaded. For more information on the LANGUAGE LOAD command, see “LANGUAGE LOAD” on page 125.

## AUTOSIZE | NOAUTOSZ

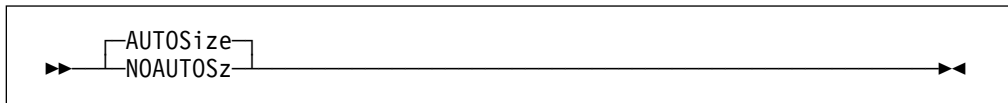

AUTOSIZE tells IDF to automatically size Disassembly windows, Dump windows, and LSM Information windows when a window is opened or closed. IDF also automatically places all opened windows so that each window's upper border overlays the lower border of the window last opened.

NOAUTOSZ tells IDF to not automatically size Disassembly windows, Dump windows, and LSM Information windows when a window is opened or closed. When a window is opened, IDF places it at the top of the screen.

## BCX | NOBCX

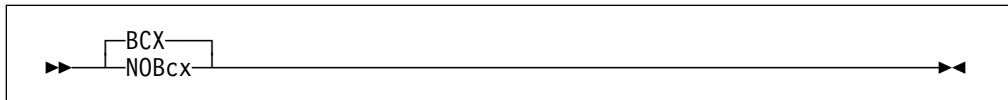

When the instruction displayed on the main panel is a BC or BCR, BCX shows an extended branch mnemonic instead of the CC mask when disassembling the instruction. Mnemonics used are those for use after compare instructions. This option has no effect on branch relative instructions.

NOBCX does not show BC and BCR instructions as their extended mnemonics, but shows the CC mask instead.

## CKSUBCM

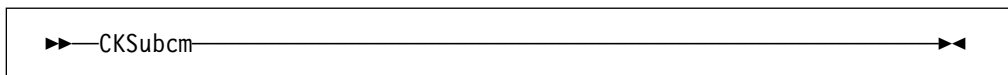

When the CKSUBCM option is set, IDF checks that its subcommand environment is intact before executing a REXX exit routine. The CKSUBCM option is intended for use in hostile environments which cut off the subcommand chain.

## CMDLOG

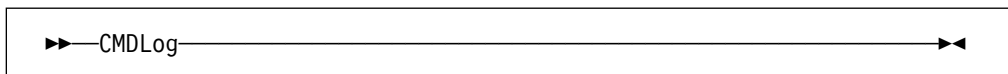

When the CMDLOG option is set, IDF logs each operator command in the command log. For the location of the command log, and more information about logging, see “Command Record and Playback Features” on page 72.



### EXITEXEC

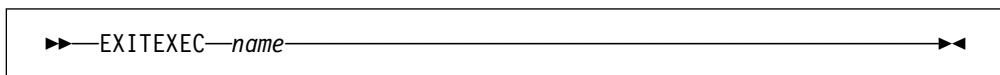

EXITEXEC supplies the name of the exit routine.

### FASTPATH | PATH | PATHFILE

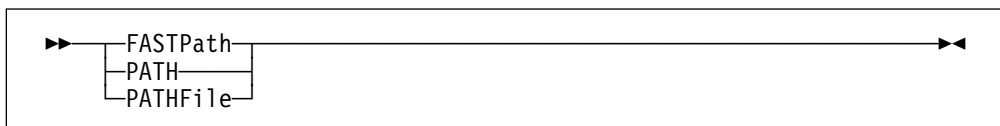

FASTPATH displays the number of times each instruction was executed, at the right side of the disassembly listing. Equivalent to the PATH option in function, but provides enhanced performance.

PATH produces the same display.

PATHFILE produces the same display as PATH, but at the end of operation, writes the collected data to:

- On CMS, file "ASM PATHDATA *fm*", where *fm* is specified by the MODE option (and defaults to file mode A1).
- On TSO, the dataset pointed to by the PATHDATA DD name.
- On VSE, to SYSLST.

See "The PATH, FASTPATH, and PATHFILE Options" on page 32 for more information.

### FULLQUAL

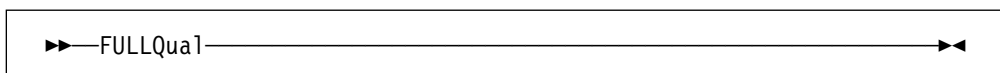

FULLQUAL always displays and returns symbolic addresses with the module name included. The default is to include only the module name, if the module containing the address is not the currently qualified module. See "Addresses Displayed by IDF" on page 75 for more information.

### HEXDISP

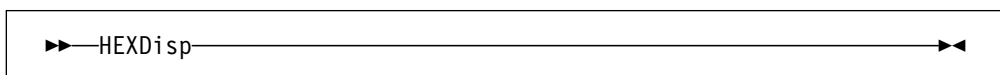

When the HEXDISP option is set, hexadecimal notation is used in disassembled instructions for all displacements from symbols, or displacements which cannot be related to symbols.

## HEXINPUT

```
▶▶—HEXInput—————▶▶
```

When the HEXINPUT option is set, IDF assumes that numbers input without any explicit indication of base are hexadecimal. If the first digit of a hexadecimal constant is not zero, IDF interprets it as the name of a symbol.

## IMP Macro | NOIMP Macro

```
▶▶—IMP Macro  
NOIMP Macro—————▶▶
```

IMP Macro permits implied macros to be executed from the command line.

NOIMP Macro disallows the implied execution of macros from the command line. With this option in effect, macro invocations must be prefixed by the MACRO keyword if they are to be found and executed.

## INVPSW | NOINVPSW

```
▶▶—NOINVPSW  
INVPSW—————▶▶
```

When the INVPSW option is set, it lets you set the PSW to any combination of hexadecimal digits through the SET PSW command.

When the NOINVPSW option is set, the PSW may only be set to a valid PSW through the SET PSW command.

## ISA (CMS only)

```
▶▶—ISA—address—————▶▶
```

ISA defines the address of a 16-byte doubleword-aligned interrupt save area that is to be used by all of IDF's first level interrupt handlers.

Valid forms for *address* are X'*nn*', F'*nn*', and *nn*. The address must reside in the first 4k of storage. The default value is X'500.'

## LIBE (TSO and CMS)

```
▶▶—LIBE—fn—————▶▶
```

- On TSO, the LIBE option specifies that the target load module should be loaded from an alternate DD name. A "\$" indicates that the target should be loaded from the standard OS load module search order.
- On CMS, the LIBE option specifies that the target program is to be loaded from an OS-style LOADLIB rather than from a CMS-style MODULE file. The *fn*

## Running IDF

provided is "\$", which indicates a CMS GLOBAL command has specified the necessary LOADLIB, or the file name of the LOADLIB, which is added to the list of GLOBAL LOADLIBs as the first library.

### LINE (CMS only)

▶▶—LINE—*line-address*————▶▶

The LINE option provides a means of telling IDF to use a terminal other than the virtual console, and is useful when debugging full-screen applications. Specify the line address in explicit hexadecimal or explicit decimal notation.

### LUNAME (VSE only)

▶▶—LUName—*lu-unit*————▶▶

The LUNAME option defines the *lu-unit*, the VTAM logical unit name of the terminal to be used by IDF. This is *needed* to run IDF in VSE.

### LSMDEBUG

▶▶—LSMDebug————▶▶

Not for general use.

LSMDEBUG enables the internal diagnostic trace of the IDF Language Support subsystem.

### MACROLOG

▶▶—MACROLog————▶▶

When the MACROLOG option is set, all IDF commands that are issued by macros or exit routines are written to:

- On CMS, "ASM MACROLOG *fm*", where *fm* is specified by the MODE option (and defaults to file mode A1).
- On TSO, the commands are written to the dataset defined by the MACROLOG DD name.
- On VSE, the commands are written to the dataset defined by the MACROLG DLBL.

### MODE (CMS only)

▶▶—MODE—*file-mode*————▶▶

When the MODE option is set, the "CMDLOG" and "PATHDATA" files are read from or written to the minidisk at the specified *file-mode*. The "MACROLOG" file is written to the minidisk at the specified *file-mode*.

## MODMAP | NOMODMAP (CMS only)

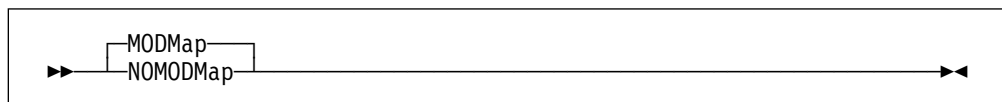

When the MODMAP option is set, IDF prefers the "fn MAP \*" file over a "LOAD MAP \*" file for symbol information. If no "fn MAP \*" is found, IDF checks for a "LOAD MAP \*" file.

When the NOMODMAP option is set, IDF prefers the "LOAD MAP \*" file over a "fn MAP \*" file for symbol information. If no "LOAD MAP \*" is found, IDF checks for a "fn MAP \*" file.

## NODSECTS

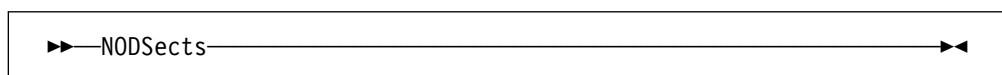

The default is to load symbols that occur in DSECTS. The NODSECTS option ignores these symbols.

## NUCEXT (CMS only)

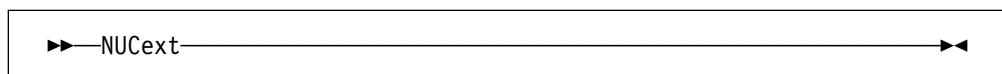

When the NUCEXT option is set, the program is supposed to run as a CMS nucleus extension and is already loaded.

## OFFSET

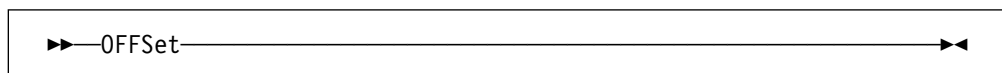

When the OFFSET option is set, IDF shows dump and disasm addresses in terms of the currently set offset value. Data at the address specified by the current offset is shown as +00000000.

## OLDBREAK

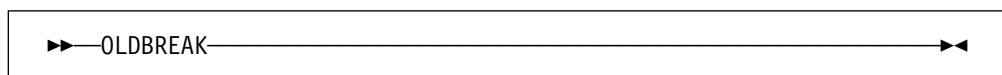

The OLDBREAK option sets an alternative mode of operation for the BREAK command. This mode of operation does not "toggle" a breakpoint. If the BREAK command is issued against an address where a breakpoint is already set, IDF issues an error message.

## Running IDF

### PASSPGM

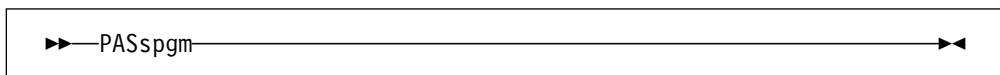

The PASSPGM option makes IDF pass program interruptions that are not the result of a PER event to the CMS, MVS or VSE program interrupt handler. Used for debugging exit routines.

**Warning:** If the target program has not activated an exit routine to trap the interrupt, IDF abends. You may need to re-IPL CMS or logon to TSO again following the debugging session. On VSE, PASSPGM occurs immediately on STXIT PC entry. If the STXIT is not present, then IDF traps the program check.

### PROFILE | NOPROFIL

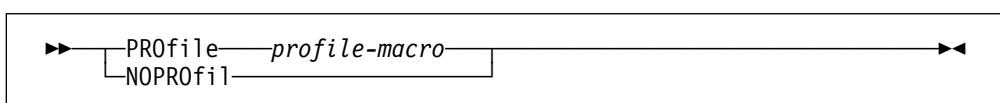

PROFILE specifies the name of the initial profile macro to be run.

NOPROFIL stops IDF executing an initial profile macro.

If neither PROFILE nor NOPROFIL are specified, IDF attempts to run an initial profile macro called PROFILE. If PROFILE is not found, then no initial profile macro is run.

### QWDUMP

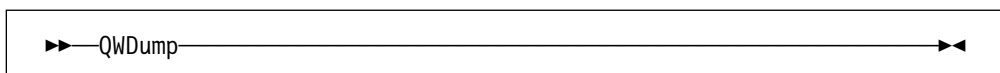

QWDUMP applies to unformatted dump displays only; it forces all displays to begin on a "quad-word" boundary (the low order hex digit is zero).

### RISK

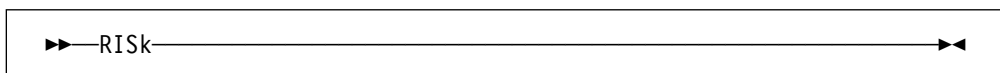

When the RISK option is set, IDF ignores as many error indications as possible. This may result in an IDF crash.

Setting the option may allow tracing of CMS services or DCSS-resident code under some circumstances.

### RLOG

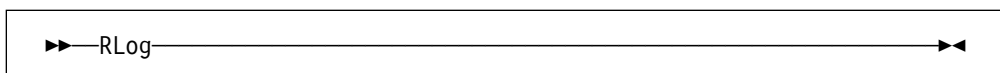

When the RLOG option is set, as soon as the PROFILE macro has completed and the target program is ready for execution, all the commands in the command log

file are executed. Then the CMDLOG option is set. This provides a means of resuming an interrupted earlier debugging session.

For more information about command logging, see “Command Record and Playback Features” on page 72.

## ROWSTYLE

```

>>—ROWstyle—————><

```

When the ROWSTYLE option is set, IDF uses the "traditional" row-style arrangement for the register display. The default is to display in columns.

## SBORDER

```

>>—SBORder—————><

```

When the SBORDER option is set, IDF does not use APL characters in window borders. This is useful when running IDF on a terminal emulator that does not support APL characters.

## SCDACTIV

```

>>—SCDACTIV—————><

```

When the SCDACTIV option is set, IDF collapses its subcommand environment before activating the target program, and re-creates it when control returns to IDF. This option is not expected to be useful in general.

## SELFNUCX (CMS only)

```

>>—SELFNUcx—symbol—————><

```

The code is self-nucxloading, so IDF does not check the length shown in the SCBLOCK to see that it matches the length in the MODULE.

*symbol* defines the start of the nucxloaded code.

For example: selfnucx freego

## STOPNOP | NOSTOPNP

```

>>—STOPNOP
   | NOSTOPNP—————><

```

STOPNOP tells IDF to stop on NOP and NOPR instructions that follow BAL, BALR, BAS, and BASR instructions.

NOSTOPNP prevents IDF from stopping on NOP and NOPR instructions that follow BAL, BALR, BAS, and BASR instructions.

### STOPSTMT | NOSTOPST

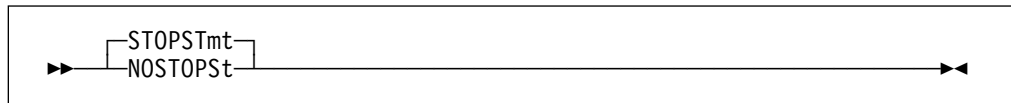

STOPSTMT tells IDF to stop single-stepping for a STMTSTEP or STEP command if it reaches a location that is within a code section for which IDF Language extract data was not loaded. This is done in an attempt to avoid what otherwise appears to be a loop.

NOSTOPST tells IDF to continue single-stepping for a STMTSTEP or STEP command if it reaches a location that is not within a code section for which IDF Language extract data was loaded. For more details see “Controlling Single-stepping your Program” on page 79

### SVC97 | NOSVC97 (TSO only)

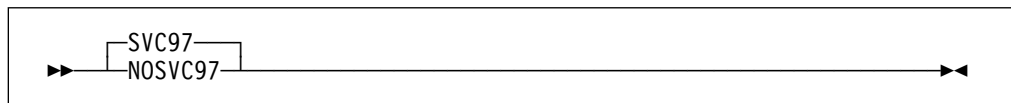

When the SVC97 option is set, IDF uses SVC 97 for breakpoints.

When the NOSVC97 option is set, IDF does not use SVC 97 for breakpoints. Instead, it uses invalid opcodes.

For more details see section “Breakpoint Method Selection” on page 35.

### SWAP

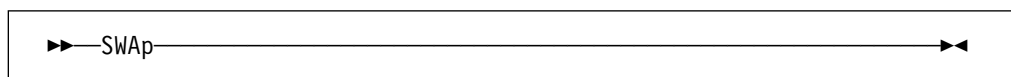

SWAP tells IDF to capture the target's screen. You need this option when you are debugging full-screen applications, and need to enter information on the screen. You switch between the IDF debugging screen and the target application through the SWAP command.

### SYSTEM (CMS only)

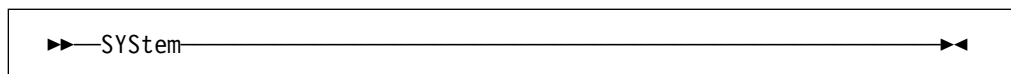

When the SYSTEM option is set, the program runs in system key (key=0).

## TRACEALL

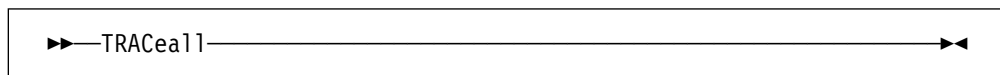

When the TRACEALL option is set, and single-step mode is on, IDF traces executed instructions as much as possible.

This *does not* include tracing in CMS services (though the RISK option may provide access) or other code that resides above the address in the VMSIZE word of NUCON. It *does* include tracing in nucleus extensions called through BALR linkage if they fall below the VMSIZE limit.

The default is to limit tracing to the target program's defined limits.

This option is set off through the SET OPTION command.

## TRANS (CMS only)

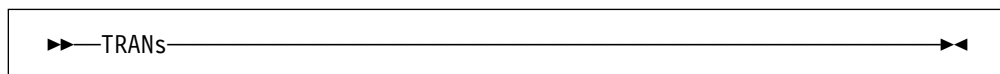

When the TRANS option is set, the program runs as a transient.

## UNFTDUMP

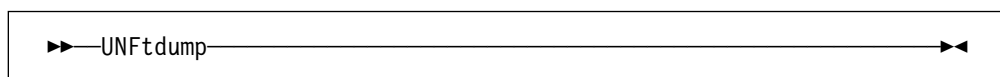



When the UNFTDUMP option is set, the memory dump does not show symbols. The formatted dump display may still be obtained with the DUMPMODE command.

---

## Initialization of General-Purpose Registers (GPRs)

The GPRs are initialized by IDF to the value  $X'FEFEnn0F'$  (where  $nn$  is the register number, 00 through 0F), with the following exceptions:

- R12 and R15 contain the target program's entrypoint address.
- R13 points to a 24-word save area (doubleword aligned).
- **TSO**
  - R1 contains the parameter pointer
    - If the COMMAND option is *not* specified, R1 points to a standard MVS CALL format parameter list.
    - If the COMMAND option is specified, R1 points to a standard TSO Command Processor Parameter List (CPPL). For more details, see “Loading Programs” on page 37.
  - If SVC 97 is being used for breakpoints, R14 points to an SVC 97; otherwise, it points to an  $X'01FF'$ . IDF uses either of these to determine if control was returned by the target program. **TSO**
- **CMS**

- R0 and R1 contain parameter pointers in the usual CMS fashion (for more information, see “How to Specify Parameters for Your Program” on page 44).
- If the program is a nucleus extension, R2 contains the address of its SCBLOCK.
- R14 points to an X'01FF' used by IDF to determine that the target program has returned control. 
- 
  - R1 contains the parameter pointer
  - R14 points to an X'01FF' used by IDF to determine if control was returned by the target program. 

---

### Initialization of Floating Point Registers

The FPRs are initialized by IDF to X'0000000000000000'.

---

### Initialization of Access Registers

Access registers AR0 and AR2 to AR15 are initialized by IDF to X'00000000'.  
AR1 is initialized by IDF to X'00000001'.

---

### The PATH, FASTPATH, and PATHFILE Options

Use these options to display how many times an executed instruction was executed. From the display you can determine:

- Sections of code that were not executed  
These sections are either sections not exercised by testing, or "dead code" that will never be executed, and hence you can remove from the program.
- Sections of code that were executed many times  
These are called "hotspots" in your program: sections where by refining the program algorithm or implementation, you can speed up program execution.

For example, to execute the CMS program "MYPROG" with the PATH support enabled, issue the command:

```
ASMIDF MYPROG (PATH /Parms for MYPROG
```

If you specified the PATH or PATHFILE options when IDF was invoked, you can choose an alternative algorithm for collecting the instruction execution count information. You can set the FASTPATH option only after the target program is loaded, and before any execution counts are collected.

### Using the PATH Option

If you specify the PATH option, the number of times each instruction was executed is displayed in a column on the right of the open Disassembly windows. You must also have the disassembled text displayed (SHOW DISASM), as the numbers are displayed to the right of these disassembled lines. The same applies if the HISTORY command is used in conjunction with the PATH option.

If the count exceeds 7 digits, the leftmost digits are truncated. This is unlikely, as executing individual instructions 10 million times through IDF imposes quite a load on the system.

## Using the PATHFILE Option

If you want to capture the PATH information for more detailed analysis, you can specify the PATHFILE option rather than PATH. When you leave IDF, this information is saved in a file:

- On CMS, the file "ASM PATHDATA A1" is written to disk.
- On TSO, data is written to the dataset pointed to by the "PATHDATA" DD statement.
- On VSE, data is written to SYSLST.

The columns in this file are, from left to right:

1. Execution count
2. Absolute memory address of the instruction
3. Name of the module containing the address
4. Address of the instruction within the module (offset)
5. Symbolic name of the instruction

If you plan to use this option, make sure you have plenty of free disk space. Also be aware that each instruction needs 8 bytes of free storage, plus 20 bytes of control information for every 64K block of information.

## Using the FASTPATH Option

You can also consider the FASTPATH option, which records execution counts in a different way. Where the PATH option uses 8 bytes of storage for every instruction executed, FASTPATH uses only 4, but allocates a contiguous block of storage to record information by assuming that the maximum number of instructions in your program is the program size divided by 2. Thus the FASTPATH option may, or may not, take more storage than the PATH option. However, it does not have to scan a list to find the instruction count information, so it executes in *much* less time.

The FASTPATH option is really a "mode" type of setting. The type of storage allocation and recording performed is determined by whether you issue a SET OPTION ON FASTPATH or a SET OPTION ON PATH command first. Once you have set the FASTPATH option to ON, you can use SET OPTION ON/OFF PATH to turn execution recording on and off; the allocation method does not change once it is initially set. Because the allocation mechanism assumes a given program size and start address, the SET BASE and SET SIZE commands may not be used after the FASTPATH option is set.

When using the FASTPATH option, instruction count information is only collected for the original target module. All other instructions executed are ignored.

### Excluding Called Subroutines

If you have subroutines in your program that you do not want to be included in PATH or FASTPATH processing, use the SKIPSTEP command. This causes IDF to skip PATH and FASTPATH processing when you call a subroutine on the list of subroutines being skipped. That is, for the purposes of PATH and FASTPATH processing, the skipped subroutine is treated as one instruction: the subroutine call itself.

---

## Chapter 5. Debugging Programs on TSO

On TSO, IDF supports the following:

- User-Area Programs
- Programs in the MVS Link List

This chapter describes how to debug each of these.

IDF supports the debugging of programs with these formats:

- Load Module members
- Programs in storage
- Program Objects

---

### Dataset Naming Conventions

Some IDF commands cause data to be written to or read from files. Since IDF was originally written to run on CMS, the commands are oriented towards the naming conventions used by the CMS file system.

The mapping of the CMS file conventions to TSO is:

#### **CMS      Equivalent on TSO**

<b>fn</b>	PDS member name (ignored if using sequential file)
<b>ft</b>	DDNAME, which in turn points to the TSO dataset name
<b>fm</b>	not used on TSO

**Note:** You must allocate the DDs using TSO ALLOC commands, or place them in your TSO startup procedure JCL. No dynamic allocation is performed.

---

### Breakpoint Method Selection

On TSO, IDF has two methods of setting breakpoints:

- Using SVC 97, the TSO/E TEST breakpoint SVC
- Using invalid opcodes.

Both methods have advantages and disadvantages.

#### **SVC 97 Breakpoints**

The advantage of using SVC 97 for breakpoints is that IDF can then debug code that makes use of MVS subtasking or sets up (E)STAE or (E)SPIE exits. Also, IDF can debug ISPF dialogs.

The disadvantage is that you must install IDF in the MVS Link List or your STEPLIB, or via the TSOLIB command. You cannot install it in a TASKLIB or ISPLLIB concatenation. The reason for this is that IDF must be invoked directly from TSO/E READY or from a CLIST that it is invoked from TSO/E READY. You *cannot* invoke IDF from a REXX EXEC or under ISPF except by using the TSOEXEC command. For an example of how to debug ISPF dialogs, see “ISPF Applications” on page 41.

### Invalid Opcode Breakpoints

The advantages of not using SVC 97 for breakpoints are:

1. You can install IDF in a TASKLIB or an ISPLLIB.
2. You can more easily invoke IDF under ISPF.

This is useful if your LOGON PROC does not have a STEPLIB that you can write to.

The disadvantages of not using SVC 97 for breakpoints are:

1. IDF cannot debug code that makes use of MVS subtasking or sets up (E)STAE or (E)SPIE exits. (When IDF is invoked with the NOSVC97 option to test a program running under the LE/370 environment, the LE/370 NOSTAE and NOSPIE options must be used.)
2. IDF cannot debug ISPF dialogs.

### Specifying the Breakpoint Method

Options allow you to select the method used for setting breakpoints:

**SVC97** Tells IDF to use SVC 97 for breakpoints. This is the default.

**NOSVC97** Tells IDF not to use SVC 97 for breakpoints.

Specify an option at invocation, or with a SET command in the PROFILE macro.

The SVC97 and NOSVC97 options cannot be set after IDF has loaded your program. As a result, if the profile macro issues a LOAD or a LOAD MODULE command and you do not wish to use the default breakpoint method, you must set the NOSVC97 option before issuing the LOAD or LOAD MODULE command.

Specifying the SVC97 or NOSVC97 option at invocation overrides the setting of NOSVC97 or SVC97 in the PROFILE macro.

---

## How to Specify Parameters for Your Program

To pass parameters to your program, append them to the ASMIDF command after a slash (/). IDF interprets anything that follows a slash as parameters that should be passed to the target program.

The parameter string is passed to the target in standard MVS EXEC PGM style. That is, R1 points to a word that points to a halfword length field that is followed by the parameter string itself.

```
* TSO PROGRAM Parameter List -----  
PLIST DC A(PARMS+X'80000000')  
      |  
      v  
PARMS DC AL2(L'CMDSTR)  
CMDSTR DC C'original command string'
```

### The COMMAND option

To pass a parameter string as a standard TSO Command Processor Parameter List (CPPL), use the COMMAND option. The first token after the slash must be the command name, which is then followed by its parameter string.

```

* TSO COMMAND Parameter List -----
CPPL  DC   A(command buffer)
      DC   A(UPT)             copied from IDF invocation
      DC   A(PSCB)
      DC   A(ECT)

↓
CMDBUF DC   AL2(length of command buffer)
      DC   AL2(offset to first non-blank byte after verb)
CMDSTR DC   C'original command string'
    
```

The COMMAND option does not work exactly like the CP option of the TSO/E TEST command. The examples in Appendix E, “Migrating from TSO/E TEST to IDF” on page 274 compare the use of these two options.

You can use the COMMAND option for other special environmental setups. For more details, see “Programs Requiring Environmental Setup” on page 39.

#### A warning about leading blanks

All blanks between the slash (/) and the parameters to your program are included in the information passed to your program. If you do not want initial blanks passed to your program, you must place the parameters immediately after the slash, without intervening blanks.

#### Programs that use IKJSCAN

When invoking IDF from another TSO program that calls the TSO service IKJSCAN, such as ISPF, an extra right parenthesis is added to the end of the command used to invoke IDF.

To prevent this extra parenthesis from becoming part of the parameter passed to your program, add a close parenthesis before the slash or the command option. This extra parenthesis is ignored by IDF and prevents IKJSCAN from adding one at the end of the IDF invocation command.

## Loading Programs

| How IDF loads your target program is dependent on whether the LIBE option is  
| used or not.

| If the LIBE option is NOT specified, then IDF uses the standard MVS load module  
| search order. However after the load completes, IDF will attempt to read the  
| module to determine the module map. This read will fail unless the module was  
| loaded from a STEPLIB, TASKLIB or ISPLLIB (when in ISPF) dataset.

If the LIBE option is specified, the next option token specifies the DD name of a pre-allocated DD concatenation to be used in loading the target. If the target is not in the specified concatenation of libraries the target is *not* loaded using the standard MVS search order.

### TASKLIBs and the SVC97 option

If the NOSVC97 option is specified, the TSO TEST SVC 97 support is not used for breakpoints.

In this case, IDF does *not* set up a TASKLIB, contrary to what is normally done when TSO/E CALL or TEST commands are used.

Programs that dynamically load other modules and programs that are link-edited as overlay programs may get MVS System 106 ABENDs under IDF, unless the library in which the target program resides is in the STEPLIB, ISPLLIB, or other TASKLIB DD concatenation.

If MYPROG is a program that is normally invoked directly from the TSO/E READY prompt, you could debug it with the following IDF command:

```
ASMIDF myprog /Parms for MYPROG
```

provided that myprog is loaded from a TASKLIB or STEPLIB.

### File Allocation Requirements

If MYPROG is a program that is normally executed in MVS Batch, you must use the TSO ALLOC command to allocate needed datasets before invoking MYPROG under IDF. When you exit IDF, use the TSO FREE command to release these datasets.

Also remember to allocate and free the DDs that are needed for IDF operation. These include:

<b>ASM</b>	Used to access the PDSs holding the IDF REXX EXECs used to customize IDF for a particular task.
<b>ASMLANGX</b>	Used to access the PDSs holding the IDF Language extract data files, if you want source-level debug.

If you plan to execute the program more than once under IDF, write these commands into a REXX EXEC or CLIST.

### The TSOEXEC Command

Invoke IDF with the TSO/E TSOEXEC command.

- This is *optional* when IDF is invoked:
  - Directly from the TSO/E READY prompt
  - From a CLIST that was invoked directly from the TSO/E READY prompt
- This is *needed* when IDF is invoked:
  - From a REXX EXEC
  - From a CLIST other than directly from the TSO/E READY prompt
  - Under ISPF.

---

## Programs Requiring Environmental Setup

If RXMYPROG is a REXX function package that permanently loads itself as a system extension when first executed, and you are interested in debugging it when it is called by a REXX exec called TESTER, to which you must pass a parameter, then load the REXX function into storage, and invoke IDF:

```
ASMIDF rxmyprog (COMMAND/exec tester a
```

### The COMMAND option

The COMMAND option tells IDF that the string following a slash (/) is not an argument string to be passed to your program, but is instead a command that it should issue to begin the debugging operation.

This COMMAND is LINKed to, and if it is an EXEC, you must precede it with a percent (%) sign. The percent sign signifies an implicit EXEC, and the command string is passed to the EXEC command for execution.

You can use this technique to debug user-area programs that need environmental setup.

When the COMMAND option is specified:

- IDF starts, but the registers and PSW are not displayed if the Current Registers window or Old Registers window is open.
- Set a breakpoint at the start of your program, or set a deferred breakpoint with the DBREAK command, and then press the RUN key.
- IDF then issues the command you specified.
- When the breakpoint is reached, IDF issues a message to tell you that it has reached a breakpoint.

The registers and PSW are now available for inspection and modification. Before the first breakpoint, IDF does not display the registers and PSW.

---

## Dynamically Loaded Programs

The IDF DBREAK command provides a powerful deferred breakpoint facility to allow the simple debugging of programs that are dynamically loaded with standard system calls. See “DBREAK” on page 104 for details.

### Warning

If your program is dynamically loaded, and then deleted from storage, any existing breakpoints are invalidated. Use the IDF DROP MODULE command to notify IDF that the module definition is no longer valid.

DROP MODULE removes all breakpoints that are currently defined for locations within this module. Any deferred breakpoints (from previous DBREAK commands) are reactivated in case this module is loaded into storage again, possibly at a different location.

If your program is dynamically loaded in a manner that is not supported by DBREAK (such as having your own routine that loads and relocates an object module), you need another solution.

The basic need is for IDF to gain control when your program begins execution.

- If you are using the SVC97 option, you should insert an SVC 97 (X'0A61') at the entry point of your program using one of the following methods:
  - If your program is written in assembler, insert an SVC 97 opcode in your program source.
  - If a Load Module editor is available, change the opcode at the entry point to an SVC 97. Record the original opcode for later restoration.
  - Use a binary editor (such as the ISPF (PDF) editor in HEX mode), to edit the Object Module to change the opcode at the entry point to an SVC 97. Record the original opcode for later restoration.
- If you are using NOSVC97 option, you should insert an invalid opcode (such as X'0000') at the entry point of your program using one of the following methods:
  - If your program is written in assembler, a DC X'0000' data directive in your program source.
  - If a Load Module editor is available, change the opcode at the entry point to X'0000'. Record the original opcode for later restoration.
  - Use a binary editor (such as the ISPF (PDF) editor in HEX mode), to edit the object Module to change the opcode at the entry point to X'0000'. Record the original opcode for later restoration.

Invoke IDF (use the COMMAND option, as described in “Programs Requiring Environmental Setup” on page 39), and press the RUN key.

IDF issues the command you specified with the COMMAND option, and your program is dynamically loaded into memory. It then executes the instruction (SVC 97 or X'0000') that you inserted.

IDF issues a message saying that either an operation exception occurred or a breakpoint was reached.

At this point:

- If an extra instruction (X'0000') or the SVC 97 was inserted, you need to open the Current Registers window, and use IDF's register typeover capability to update the PSW to advance the current execution address by 2.

You can optionally replace the SVC 97 (or X'0000') by a NOPR R0 (X'0700') instruction. This stops IDF receiving control at this location if the instruction is executed again.

- If an existing instruction was replaced (by an SVC 97 or X'0000'), you can restore the modified instruction to its original value by opening a Disassembly window or Dump window and using IDF's storage typeover capability.

You should now be able to continue debugging the program as usual.

---

## Programs Invoked by REXX

Some programs, particularly REXX function packages, need environmental setup for debugging because they are invoked by the REXX interpreter. There are other special considerations that apply to any program invoked by REXX.

REXX functions must return an EVALBLOK. If you quit from IDF while in the middle of a REXX function, an error message is issued by the REXX interpreter, and you may have to LOGOFF and then LOGON to TSO again.

There is no practical way for IDF to stop this.

---

## ISPF Applications

You can use IDF to debug an application program that needs an ISPF environment present, if SVC 97 is used for breakpoints.

The following examples describe a number of ISPF application debug scenarios.

- To debug an ISPF dialog program which resides in a dataset in the STEPLIB allocation:

From the TSO/E READY prompt:

```
TSOEXEC ASMIDF XYZZY (COMMAND/ISPSTART PGM(XYZZY))
```

Once in IDF,

```
BREAK (XYZZY)
```

then

```
RUN
```

- To debug an ISPF dialog program which resides in a dataset in the ISPLLIB allocation:

From the TSO/E READY prompt:

```
TSOEXEC ASMIDF XYZZY (LIBE ISPLLIB COMMAND/ISPSTART PGM(XYZZY))
```

Once in IDF,

```
BREAK (XYZZY)
```

then

```
RUN
```

---

## DB2 Applications

IDF may be used to debug an application program using DB2 EXEC SQL statements. There are a number of environmental requirements which must be met:

- The IDF NOSVC97 option must be used.
- If running application under the Language Environment, then the LE options NOSTAE and NOSPIE must be used.
- The DB2 commands must be placed on the TSO stack to be executed. The preferred method is to use a CLIST, and place the DB2 commands within DATA and ENDDATA statements.

## Debugging on TSO

```
|          PROC 0 LIBE('ASMIDF.SQL.LOAD') MEMBER(SQLPROG1) OPT('PARMS') IDF
|          /* */
|          CONTROL NOCONLIST FLUSH NOLIST
|          PROFILE NOPAUSE
|          /* */
|          ALLOC FI(ASMLANGX) REUSE DA('DMS.SQL.ASMLANGX') SHR
|          ALLOC FI(ASM) REUSE DA('ASMIDF.PROD.IDF') SHR
|          /* */
|          ALLOC FI(LIBEDD) REUSE DA('&LIBE') SHR
|          /* */
|          IF &IDF = IDF THEN +
|              DO
|                  DATA
|                  DSN
|                  RUN CP PLAN(&MEMBER)
|                  TSOEXEC ASMIDF &MEMBER (LIBE LIBEDD NOSVC97 / &OPT
|                  END
|                  ENDDATA
|              END
|          ELSE +
|              DO
|                  DATA
|                  DSN
|                  RUN CP PLAN(&MEMBER)
|                  &MEMBER &OPT
|                  END
|                  ENDDATA
|              END
|          FREE FI(ASMLANGX LIBEDD ASM)
|          EXIT CODE(0)
```

---

## Causing a Break-In Event

A "break-in event" is an event that causes IDF to break in to the target program's execution and regain control, even though a breakpoint was not reached. For example, you might need to cause a break-in event if your program is in an infinite loop that does not contain a breakpoint.

When IDF initially invokes your program, it establishes an ESTAE exit. If your program has not established its own ESTAE exit (which overrides the IDF ESTAE), IDF should receive control when the ATTENTION key is pressed.

When a break-in event is recognized, IDF displays the IDF user interface screen and issues a message acknowledging the event. You can then continue your debugging session.

**Note:** This requires SVC97 to operate normally.

---

## Your Program's Defined Limits

IDF considers "your program" to be any location within your initial program module, and any extra program modules that you have defined.

- When your program is loaded, IDF determines its limits from the operating system.

- You can *implicitly* define extra modules as the result of triggering a deferred breakpoint established with a DBREAK command.
- You can *explicitly* define extra modules with the IDF MODULE command:
  - If the module is described by a Contents Directory Entry (CDE) you can establish the module definition with a MODULE CDE command.
  - You can define an explicit module origin and size with the MODULE BASE and MODULE SIZE commands.
  - You can establish an explicit module's CSECT structure with a LOAD SYMBOLS command (see “LOAD” on page 134).

The origin and size of the programs known to IDF are displayed in the Target Status window, when open.

Whenever possible, IDF notifies you if your program is preparing to branch to a location outside its defined limits. This is often useful in locating a "wild branch", for example to location zero.

If you have specified the TRACEALL option, IDF considers the defined limits of your program to begin at location zero and extend upward to the end of storage. Thus when you specify TRACEALL, you can trace through all of virtual memory.

Care should be taken if you attempt to trace through protected (read only) storage.

---

## Programs Performing Full-Screen I/O

Debugging programs that perform full-screen I/O is generally a difficult task, because when the debugger reaches a breakpoint, the screen image created by your program is lost. You may become frustrated if you need to look closely at the screen image to determine if the program is working properly.

IDF provides the SWAP option to make this kind of debugging easier. If MYPROG was a user-area program that performed full-screen I/O, you could debug it with the following IDF command:

```
IDF myprog (SWAP /Parms for MYPROG
```

When the SWAP option is in effect, IDF attempts to respect the screen image created by your program. In single-step mode, IDF does nothing special. However, if you set a breakpoint in your program and press the RUN key to run the target program to that point, before turning control over to your program, IDF restores any saved screen image. When the breakpoint is reached, IDF captures the contents of the screen and saves it before presenting its own display. The same process occurs when you use the UNTIL command.

To capture the screen image, IDF uses the Read Buffer command in Character Mode, so even program symbol sets should be saved.

To see the saved screen at a breakpoint, issue the SWAP command. To return to the IDF screen, just press ENTER.

---

## Chapter 6. Debugging Programs on CMS

---

### Program Preparation on CMS

After all program sections are prepared and the process of building the final module is complete, save the LOAD MAP file. This gives IDF the location of program sections within the module. If multiple programs are being debugged, rename the file to "*modname* MAP" (where *modname* is the file name of the MODULE).

By default, any local symbols which are present in SYM records within the program object code are placed in the MAP file, with the prefix

Invalid card -

IDF uses this information if, for some reason, you cannot use the ASMLANGX files for source-level debugging. Suppress these records with the NOINV option of the CMS LOAD command if you wish to minimize the size of the MAP file.

On CMS, IDF debugs:

- User-Area Programs
- Transients
- Nucleus Extensions Loaded Explicitly
- Self-Loading Nucleus Extensions

IDF supports debugging programs in the following formats:

- CMS 5.5 (and later) format MODULE
- LOADLIB members
- OBJECT (TEXT) files
- Programs in storage

---

### How to Specify Parameters for Your Program

To pass parameters to your program, include them at the end of the IDF command after a slash (/). IDF interprets anything that follows a slash as parameters that should be passed to your program.

These parameters are parsed into tokenized and extended parameter lists. The flag byte in R1 has the same contents it would have if your program was invoked directly. If IDF is invoked from an EXEC-1 program, the contents of R0 at the time IDF was invoked are propagated to your program's R0.

```

* CMS Parameter Lists -----
* A) Extended Parameter List
EPLIST DC   A(start of command verb)
         DC   A(start of first nonblank byte following verb)
         DC   A(first byte past the end of the argument list)
         DC   A(0)
         DS   0D                align next part on doubleword
* B) Tokenized Parameter List
TPLIST DC   CL8'command verb'
         DC   CL8'token'
         ...
         DC   CL8'token'
         DC   8X'FF'
CMDSTR DC   C'original command string'

```

**A warning about leading blanks**

All blanks between the slash (/) and the parameters to your program are included in the information passed to your program. If you do not want initial blanks passed to your program, you must place the parameters immediately after the slash, with no intervening blanks.

Unless your program is a nucleus extension (see “CMS Nucleus Extensions Loaded Explicitly” on page 46), IDF loads it into the appropriate area (user/transient) with the LOADMOD command.

For example, to debug MYPROG, normally invoked by:

```
MYPROG fn ft fm (abcd
```

You issue:

```
ASMIDF myprog / fn ft fm (abcd
```

If you want to specify more options for IDF, for example to set display colors, you specify:

```
ASMIDF myprog (COLORS RWGY / fn ft fm (abcd
```

---

## User-Area Programs

By default, CMS programs are built to execute in the *User Program Area* at location X'20000'.

Unless told otherwise, IDF assumes that you want to debug a user-area program. There are no mandatory options to specify when debugging a user-area program (although there are options you can specify to enable special features).

---

## CMS Transient Programs

Transient-area programs are special non-relocatable programs that execute in the *Transient Program Area* at location X'00E000'.

Under IDF, these programs are debugged in the same way as user-area programs but the TRANS option must be specified so that IDF knows that you want to debug a transient.

## Program Preparation on CMS

For example, if MYPROG shown above is a transient, you specify:

```
ASMIDF myprog (TRANS / fn ft fm (abcd
```

When debugging a transient-area program, you do not have access to CMS SUBSET during the debugging session. Running another transient erases your program.

---

## CMS Nucleus Extensions Loaded Explicitly

Nucleus extension programs are typically relocatable programs. They are loaded into "high" storage, typically with the CMS NUCXLOAD command. These programs become an extension to the CMS nucleus, and remain resident until removed by the CMS NUCXDROP command.

If MYPROG is a nucleus extension that you have loaded with the NUCXLOAD command you invoke IDF:

```
ASMIDF myprog (NUCEXT /fn ft fm (abcd
```

As far as IDF is concerned, this is the only difference between debugging a nucleus extension and a user-area program. You must load the nucleus extension before invoking IDF.

If the nucleus extension was loaded from a LOADLIB and not a MODULE file, use the LIBE \$ option as well as the NUCEXT option. This tells IDF to not check the MODULE file.

---

## Self-Loading CMS Nucleus Extensions

Some nucleus extensions are self-loading. They obtain nucleus free storage themselves, move in the code, and declare the nucleus extension. In this case, you must specify the symbol where the code that is moved into nucleus storage begins.

For example, if your program is a REXX function package, there is a short piece of code at the start of the program that loads the remainder as a nucleus extension. The real program begins at symbol FREEGO. You invoke IDF:

```
ASMIDF rxmyprog (SELFNUCX FREEGO/fn ft fm (abcd
```

You must pre-load the nucleus extension before invoking IDF. Since the program is self-loading and may not yet be operational, you may have to use a two-run technique with IDF:

1. First run:

For the first run, do *not* declare the program as self-loading. Invoke IDF as if the program was only going to allocate nucleus storage. Trace through the program up to the point where it normally branches to the NUCXLOADed code, then QUIT from IDF. At this point, you have effectively pre-loaded the nucleus extension.

2. Second run:

For the second run, invoke IDF with the SELFNUCX option as shown above. Since you pre-loaded it in the first run, you can now continue debugging in the NUCXLOADed code.

**Note:** It may also be possible to use the SET BASE and SELFNUCX VALUE commands to trace a self-loading nucleus extension in a single run.

---

## Programs Requiring Environmental Setup

RXMYPROG is a REXX function package that permanently loads itself as a system extension when first executed (for example, a self-loading nucleus extension on CMS). You want to debug it when it is called by a REXX exec called TESTER, to which you must pass a parameter.

Load the REXX function into storage with the command:

```
NUCXLOAD rxmyprog
```

Next, issue the IDF command:

```
ASMIDF rxmyprog (SELFNUCX FREEGO COMMAND/exec tester a
```

### The COMMAND option

The COMMAND option tells IDF that the string following a slash (/) is not an argument string to be passed to the target program, but a command that it should issue to begin the debugging operation.

This command is issued with a CMSCALL (SVC 204), so if it is an exec, you must specify that, as shown in the example above.

You can use the same technique to debug user-area programs that need environmental setup.

When the COMMAND option is specified:

- IDF starts as usual but PER is disabled, and the registers and PSW are not displayed if the Current Registers window or Old Registers window is open.
- Set a breakpoint at the start of your program, or set a deferred breakpoint with the DBREAK command, and then press the RUN key.
- IDF then issues the command you specified.
- As part of that command's execution, it should invoke the target program (RXMYPROG in this example), which is already in storage, defined to IDF, and with the breakpoint installed at or near its entry-point.
- When the breakpoint is reached, IDF issues a message to you.

PER is now available for use, and the registers and PSW are available for inspection and modification. Before the first breakpoint IDF keeps PER disabled and does not display the registers and PSW.

If practical, when using the COMMAND option, allow the target program to execute through to the point of its return to its caller (for example, to the EXEC that was invoked by the COMMAND string and which then invoked the target program). This "normal flow of control" allows any usual "house-cleaning" needed by the operating system for these call/return linkages. If instead you QUIT from the target program before its normal return, it may leave a "dangling" call linkage to the target program, without a corresponding return.

Quitting from a target program before a normal return is a particular problem on CMS. The CMSCALL (SVC 204) that was used from within IDF to call the

## Program Preparation on CMS

COMMAND string is not returned to. If this "un-paired" SVC linkage remains undetected, you may experience difficulties in CMS.

IDF termination contains special logic to check for this condition (that is, a QUIT from the target program that was invoked with a COMMAND string), and if detected, IDF:

1. Issues a linemode message warning of the problem.
2. Executes one or more CMSRET RC=999 macros until the original SVC nesting (as saved just before IDF's CMSCALL to the COMMAND string) is restored.

If the original nesting cannot be restored within 20 calls to CMSRET, or if a CMS ABEND occurs during this processing, IDF issues another warning message (suggesting that CMS be re-IPLed) and terminates.

---

## Dynamically Loaded Programs

The IDF DBREAK command provides a powerful deferred breakpoint facility to allow the simple debugging of programs that are dynamically loaded with standard system calls. See "DBREAK" on page 104 for details.

### Attention

If your program is dynamically loaded, and then deleted from storage, any existing breakpoints are invalidated. Use the IDF DROP MODULE *module-name* command to notify IDF that the module definition is no longer valid.

DROP MODULE removes all breakpoints that are currently defined for locations within this module. Any deferred breakpoints (from previous DBREAK commands) are reactivated in case this module is loaded into storage again, possibly at a different location.

If your program is dynamically loaded in a manner that is not supported by DBREAK, such as having your own routine that loads and relocates an object module, you need an alternative solution.

IDF must be able to gain control when your program starts executing.

- Insert an invalid opcode (such as X'0000') at the entry point of your program using one of the following methods:
  - If your program is in assembler, insert a DC X'0000' data directive in its source.
  - If a MODULE editor is available, change the opcode at the entry point to X'0000'. Record the original opcode for later restoration.
  - Use a binary editor (such as the ISPF (PDF) editor in HEX mode), to edit the object Module to change the opcode at the entry point to X'0000'. Record the original opcode for later restoration.

Invoke IDF (you need to use the COMMAND option, as described in "Programs Requiring Environmental Setup" on page 47), and press the RUN key.

IDF issues the command you specified with the `COMMAND` option, and your program is dynamically loaded into memory. It then executes the invalid instruction (`X'0000'`) that you inserted.

IDF issues a message saying that either an operation exception has occurred, or that a breakpoint was reached.

At this point:

- If an extra instruction (`X'0000'`) was inserted, you need to open the Current Registers window, and use IDF's register typeover capability to update the PSW to advance the current execution address by 2.

You can optionally replace the `X'0000'` by a `NOPR R0 (X'0700')` instruction. This stops IDF receiving control at this location if the instruction is executed again.

- If an existing instruction was replaced (by an `X'0000'`), you can restore the modified instruction to the original value by opening a Disassembly window or Dump window and using IDF's storage typeover capability.

You should now be able to continue debugging the program as usual.

---

## Programs Invoked by REXX

Some programs, particularly REXX function packages, need environmental setup for debugging because they are invoked by the REXX interpreter. There are other special considerations that apply to any program that is invoked by REXX.

REXX functions must return an `EVALBLOK`. If you quit from IDF while in the middle of a REXX function, an error message is issued by the REXX interpreter, and you may have to re-IPL CMS.

There is no practical way for IDF to prevent this from happening.

---

## Programs Declaring Interrupt Routines

If your program declares interrupt routines with `ABNEXIT`, `HNDEXT`, or their MVS equivalents read this section.

Remember that some interrupt routines are not automatically cleared by CMS at end of command. `ABNEXIT` is one of these. If you are in a debugging session and your program has declared an `ABNEXIT` routine, if you quit from IDF through PF3 before your program explicitly clears the exit routine, the exit routine remains in effect even when your program is no longer in memory. The next time you run a program or invoke IDF for another debugging session, a system abend is most likely, after which you need to re-IPL CMS.

It is safest if you re-IPL CMS after a debugging session where exit routines were tested. The results after IDF completes are unpredictable.

### Causing a Break-In Event

A "break-in event" is an event that causes IDF to break in to the target program's execution and regain control, even though no breakpoint was reached. For example, you might need to cause a break-in event if your program has gone into an infinite loop that does not contain a breakpoint.

To cause a break-in event, you need some preparation:

- You need to know the address of IDF's ISA (interrupt save area). If you have not specifically set it with the ISA option when invoking IDF, the default value for the ISA location is in effect, (that is, 16 bytes at X'500').
- You can cause a break-in event by obtaining the CP command prompt (typically by pressing the PA1 key), and storing any value in the first doubleword of IDF's ISA. For example: "STORE S500 00".

Do not modify the second doubleword of the ISA. Any store operation that changes the first doubleword (or any part of it) causes a break-in event at the next interrupt.

If your program has gone into an infinite loop however, there may not be any interrupts. You can ensure a steady supply of interrupts by setting the PATH option. This makes IDF take an interrupt after each target program instruction.

When a break-in event is recognized, IDF displays the IDF user interface screen and issues a message acknowledging the break-in event. You can then continue the debugging session.

---

### Your Program's Defined Limits

IDF considers "your program" to be any location within the initial target program module, and any more program modules that you have defined.

- When the target is loaded, IDF determines its limits by examining the module file.
- Extra modules are implicitly defined as the result of the triggering of a deferred breakpoint that was established with a DBREAK command.
- Extra modules are explicitly defined with the IDF MODULE command:
  - If the module is a nucleus extension, establish the module definition with a MODULE NUCEXT command.
  - If the module is a transient program, establish the module definition with a MODULE TRANS command.
  - Define an explicit module origin and size with MODULE BASE and MODULE SIZE commands.
  - You can establish an explicit module's CSECT structure with a LOAD SYMBOLS command (see "LOAD" on page 134).

The origin and size of the programs known to IDF are displayed in the Target Status window, when open.

Whenever possible, IDF tells you if your program is about to branch to a location outside its defined limits. This is often useful in finding a "wild branch", for example to location zero.

If you have specified the TRACEALL option, IDF considers the defined limits of your program to begin at location zero and extend upward to the address specified in the VMSIZE word of NUCON. Thus when you specify TRACEALL, you can trace through all of virtual memory.

Take care if you attempt to trace through protected (read only) storage.

If you specify the RISK option, IDF considers all of memory to be within your program's defined limits. Thus you could attempt to step through code in a DCSS that is actually above the address specified in the VMSIZE word of NUCON.

---

### PER Versus non-PER Mode

The Break panel provides a means of enabling or disabling what is referred to as "PER mode" operation. The method of enabling and disabling PER mode is discussed later; this section explains the difference between the two modes of operation.

PER is an acronym for "Program Event Recorder". It is a feature of the 370 and 390 hardware, and is only available in EC (Extended Control) mode.

When PER mode is enabled through the Break window (the default is for IDF to disable it), IDF puts the processor in EC mode before turning control over to the target program. This lets IDF use the PER instruction fetch, register alteration, and storage alteration features to monitor your program's execution. Single-stepping and breakpoints are available in either mode. Register stops and address stops (storage alteration stops) are available only in PER mode.

Whenever possible, IDF implements breakpoints by means of inserting an invalid opcode at the break address. In the case of a read-only DCSS, this is not possible. In this case IDF needs to use PER instruction fetch events to implement breakpoints. This can only be done when you have set PER=Y.

PER mode's benefits are:

- Register alteration stops (RegStops) are available
- Storage alteration stops (AdStops) are available

Its disadvantage is:

the number of instructions executed by IDF when PER=Y is slightly higher than when PER=N.

The disadvantage of non-PER mode is that RegStops and AdStops are not available.

When you debug your program, allowing for these benefits and disadvantages leads to better results and fewer surprises.

You are not committed to either mode for the entire debugging session. Whenever IDF reaches a breakpoint and is therefore able to display the Break window, you can change modes.

---

### Programs Performing Full-screen I/O

Debugging programs that perform full-screen I/O is generally a difficult task, because when the debugger reaches a breakpoint the screen image created by your program is lost. This can be extremely frustrating, since you may need to look closely at the screen image to determine whether the program is operating correctly.

IDF provides the SWAP option to make this kind of debugging easier. If MYPROG was a user-area program that performed full-screen I/O, you could debug it with:

```
ASMIDF myprog (SWAP /fn ft fm (abcd
```

When the SWAP option is in effect, IDF attempts to respect the screen image created by your program. In single-step mode, IDF does nothing special when SWAP is in effect. However, if you set a breakpoint in your program and press the RUN key to run the target program to that point, before turning control over to your program, IDF restores any saved screen image. When the breakpoint is reached, IDF captures the contents of the screen and saves it before presenting its own display. The same process occurs when you use the UNTIL command.

To capture the screen image, IDF uses the READ BUFFER command in Character Mode, so even program symbol sets should be saved.

If you have two terminal sessions available, then you can use the LINE option. The LINE option tells IDF to use the GRAF at the specified address for its I/O, instead of using the virtual console.

A sample procedure to do this is:

```
CP DEFINE GRAF xxx
DIAL userid xxx      <-- (from the alternate session)
ASMIDF MYPROG (LINE X'xxx'
```

If you use the LINE option instead of the SWAP option, your debug session is faster, because there is no need to constantly capture and re-write your program's screen.

To see the saved screen at a breakpoint, issue the SWAP command. To return to the IDF screen, just press ENTER.

---

### Using a Message-Trapping Tool

Many users run a message-trapping tool as a normal part of their working environment.

IDF sets up a dummy HNDEXT routine while it is in control, so that if a clock or other external interrupt occurs, the "DEBUG ENTERED" scenario is avoided.

If the target program sets up an HNDEXT routine, that new routine supersedes IDF's dummy handler without interfering with IDF operation. If IDF was invoked by another program that had set up a HNDEXT routine, IDF's dummy handler supersedes it.

Therefore, if you use a message-trapping tool that relies on HNDEXT processing to gain control and thereby intercept messages, you should disable it before starting IDF to make sure you do not lose any messages.

Many message trappers "steal" the external new PSW and perform their own interrupt handling at that level. If the message trapper you use does this, it is very likely that it can coexist with IDF. It is suggested that you test it to make sure, if you are concerned about the possibility of losing messages that arrive during a debugging session.

IDF does not affect the MSG setting, so if you do not use a message-trapping tool, none of this should affect you.

---

## Chapter 7. Debugging Programs on VSE

On VSE, IDF supports debugging of phases that are loaded into the same partition as IDF.

**Note:** Phases loaded into the SVA or Logical Transients cannot be debugged.

---

### Dataset Naming Conventions

Certain IDF commands cause data to be written to or read from files. Since IDF was originally written to run on CMS, the commands are oriented towards the naming conventions used by the CMS file system.

The mapping of the CMS file conventions to VSE is:

**CMS      Equivalent on VSE**

**fn**        VSE librarian member name.

**ft**        DLBL name, which in turn points to the VSE dataset name

**fm**        not used on VSE

On VSE, you must reference files using DLBL statements (JCL), and libraries using LIBDEF statements.

---

### How to Specify Parameters for Your Program

To pass parameters to your program, include them in the PARM= option on the EXEC ASMIDF statement.

```
// EXEC ASMIDF,PARM='phasename (LU luname idf-options/phase-parameters'
```

where:

**phasename**        is the name of the phase to be debugged

**luname**            is the VTAM LU name of the terminal you use to debug this phase

**idf-options**        are options to be passed to IDF

**phase-parameters** are parameters to be passed to your phase

---

### Loading Programs

The target program being debugged is loaded from the first sublibrary in the LIBDEF PHASE SEARCH list in which it occurs.

#### JCL Requirements

Because IDF runs from JCL, you need to specify any files that your program needs in that JCL. You need to allocate optional IDF files, such as REXX customization macros and IDF Language extract files. Even though IDF is started as a batch job, it needs a terminal (defined by its VTAM™ *logical unit* (LU) name) to run. This terminal is specified through the LUTERM option in the PARM value of the // EXEC ASMIDF statement. The LUTERM is the name used by VTAM to define the LU to the network, and is used by IDF to address the terminal.

JCL example:

```
// SETPFIX LIMIT=24K
// LIBDEF PHASE,SEARCH=(my.Library,HLASM.LIBRARY)
// LIBDEF PROC,SEARCH=(MY.PROCLIB,HLASM.LIBRARY)
// EXEC ASMIDF,PARM='MYPROG (LU MYterm /phase-parameters'
/*
```

The following JCL statements are required:

**SETPFIX LIMIT** Sets the page fix limit. IDF needs this set to 24K to allow the product exit to function correctly.

**LIBDEF PHASE** Defines the library which contains the phase map created by ASMLKEDT and the target phase.

**LIBDEF PROC** Defines the procedure library which contains any REXX procedures that might be used.

**EXEC ASMIDF** Executes the program ASMIDF (IDF) using the parameters specified with the PARM option.

---

## Dynamically Loaded Programs

The IDF DBREAK command provides a powerful deferred breakpoint facility to allow the simple debugging of programs that are dynamically loaded using standard system calls. See “DBREAK” on page 104 for details.

### Attention

If your program is dynamically loaded, and then deleted from storage, any existing breakpoints are invalidated. Use the IDF DROP MODULE command to notify IDF that the module definition is no longer valid.

DROP MODULE removes all breakpoints that are currently defined for locations within this module. Any deferred breakpoints (from previous DBREAK commands) are reactivated in case this module is loaded into storage again, possibly at a different location.

If your program is dynamically loaded in a manner that is not supported by DBREAK (such as having your own routine that loads and relocates an object module), you need to use an alternative solution.

IDF needs to gain control when your program starts executing.

You should insert an invalid opcode (such as X'0000') at the entry point of your program using one of the following methods:

- If your program is written in assembler, insert a DC X'0000' data directive in your program source.
- If a phase editor is available, change the opcode at the entry point to X'0000'. Record the original opcode for later restoration.
- Use a binary editor to edit the object Module to change the opcode at the entry point to X'0000'. Record the original opcode for later restoration.

Invoke IDF and press the RUN key, on the terminal that you have specified in the LUNAME parameter on the EXEC ASMIDF statement.

Your program is dynamically loaded into memory and executes the instruction (X'0000') that you inserted.

IDF issues a message saying that an operation exception has occurred.

At this point:

- If an extra instruction (X'0000') was inserted, you need to open the Current Registers window, and use IDF's register typeover capability to update the PSW to advance the current execution address by 2.

You may optionally replace the X'0000' by a NOPR R0 (X'0700') instruction. This stops IDF receiving control at this location if the instruction is executed again.

- If an existing instruction was replaced (by X'0000'), you can restore the modified instruction to its original value by opening a Disassembly window or Dump window and using IDF's storage typeover capability.

You should now be able to continue debugging the program as usual.

---

## Running with Subtasks

IDF detects program loads, program checks and breakpoints defined by commands for all the tasks running within a partition. To achieve this IDF uses a locking mechanism to single thread each event detected. The lock is in effect from the time the event is detected and is released when control is returned to the respective task. If IDF is interrupted while the LOCK is in effect by a STXIT IT, or STXIT OC for example, a deadlock situation may occur. Take care, when you are debugging subtasks and interruption routines are in effect, that you do not interrupt the IDF session.

---

## Running with CICS

CICS® uses subtasks, therefore to avoid the deadlocks described in the previous section you should run CICS with:

1. Run away task inoperative (that is, SIT option ICVR=0).
2. Stall Purge should be disabled for all transactions that run during the debugging session.

When issuing MSG CICS partition console commands on debug sessions, do not interrupt the IDF session.

---

## Debugging STXIT code

**STXIT PC** IDF traps program checks before any STXIT code is invoked. This lets you analyze the initial program check. If you have an active STXIT PC you can then set break points in your STXIT PC code and use the IDF RUN command to break in the STXIT PC code.

**Note:** You may need to issue the RUN command twice when a branch address is invalid, before the STXIT PC code is invoked.

**STXIT AB** IDF lets you debug your STXIT AB routines if you set break points in them. Care should be taken when debugging STXIT AB routines with subtasks. If another event is trapped by IDF at the

same time as the STXIT AB breakpoint, IDF may terminate the session due to a possible deadlock situation.

**STXIT IT, OC** IDF lets you debug your STXIT IT, OC routines if you set breakpoints in them. Refer to “Running with Subtasks” on page 56 for considerations when running with subtasks.

---

## Causing a Break-In Event

A break-in event is an event that causes IDF to break in to the target program's execution and regain control, even though no breakpoint was reached. For example, you might need to cause a break-in event if your program has gone into an infinite loop that does not contain a breakpoint.

When IDF initially invokes your program, it has established a STXIT OC exit. If your program has not established its own STXIT OC exit (which overrides the IDF STXIT OC), IDF should receive control when the console command 'MSG partition ID' is entered.

When a break-in event is recognized, IDF displays the IDF user interface screen as usual and issues a message acknowledging the event. You can then continue your debugging session.

---

## Your Program's Defined Limits

IDF considers "your program" to be any location within the initial target phase, and any more phases that you have defined.

- When the target is loaded, IDF determines its limits by examining the directory entry for the phase.
- Extra modules are implicitly defined as the result of the triggering of a deferred breakpoint that was established with a DBREAK command.
- Extra phases are explicitly defined with the IDF MODULE command:
  - If the module is described in the phase load trace table, establish the module definition with a MODULE command.
  - Define an explicit module origin and size with MODULE BASE and MODULE SIZE commands.
  - You can establish an explicit module's CSECT structure with a LOAD SYMBOLS command (see “LOAD” on page 134).

The origin and size of the programs known to IDF are displayed in the Target Status window, when open.

Whenever possible, IDF notifies you if your program is preparing to branch to a location outside its defined limits. This is often useful in locating a "wild branch", for example to location zero.

If you have specified the TRACEALL option, IDF considers the defined limits of your program to begin at location zero and extend upward to the end of storage. Thus when you specify TRACEALL, you can trace through all of virtual memory.

Care should be taken if you attempt to trace through protected (read only) storage.

---

### Programs Performing Full-Screen I/O

Debugging programs that perform full-screen I/O is generally a difficult task, because when the debugger reaches a breakpoint, the screen image created by your program is lost. This can be extremely frustrating, since you may need to look closely at the screen image to determine whether the program is operating correctly.

IDF provides the SWAP option to make this kind of debugging easier. If MYPROG was a program that performed full-screen I/O, you could debug it with the following IDF command:

```
| // EXEC ASMIDF PARM='myprog (LU myterminal SWAP /Parms for MYPROG'
```

When the SWAP option is in effect, IDF attempts to respect the screen image created by your program. In single-step mode, IDF does nothing special. However, if you set a breakpoint in your program and press the RUN key to run the target program to that point, before turning control over to your program, IDF restores any saved screen image. Then when the breakpoint is reached, IDF captures the contents of the screen and saves it before presenting its own display. The same process occurs when you use the UNTIL command.

To capture the screen image, IDF uses the READ BUFFER command in Character Mode, so even program symbol sets should be saved.

```
| To see the saved screen at a breakpoint, issue the SWAP command. To return to  
| the IDF screen, just press enter.
```

---

## Chapter 8. Windows, PF Keys, Cursor Positioning, and Other Operational Details

This chapter provides more detail on the operation of IDF.

---

### Windows

IDF has many different windows:

- AdStops window
- Additional Floating-Point Registers window
- Break window
- Current Registers window
- Disassembly window
- Dump window
- LSM Information window
- Minimized Windows Viewer
- Options window
- Old Registers window
- Skipped Subroutines window
- Target Status window

There is also a Command window which is always displayed. It contains the command input area, the message display areas, and, by default, the settings of PF keys 1 to 12. Use the SET PFKDISP command to customize the number of PF key settings displayed. The size of the Command window varies, depending on the number of PF key settings displayed. This is the only window displayed by default when IDF is started.

Each window when displayed is surrounded by a border that includes a title describing that window. The title includes the window's window number. The window number is an integer assigned in sequence as windows are opened. When a window is closed, the window numbers of open windows are reassigned.

By default, when windows are opened, IDF positions them on the screen so that their top border overlays the bottom border of the window last opened. The exceptions to this rule are:

- AdStops window
- Break window
- Skipped Subroutines window

These windows are placed on the right of the screen.

As windows are opened they are added to the bottom of the screen. Use the ORDER command to move a window to the front of the list of windows being displayed.

The Additional Floating-Point Registers window, Current Registers window, Old Registers window, the Options window, and Target Status window are of a fixed size when opened.

## Windows and PF Keys

By default, any open Disassembly windows, Dump windows, and LSM Information windows share the space on the screen not used by the other windows. They are automatically re-sized every time some window opens or closes. LSM Information windows use at most enough space to contain the information generated by the command.

Change this default behavior with the NOAUTOSZ option (AUTOSIZE is the default), or with the SET OPTION OFF AUTOSIZE command.

When AUTOSIZE is off, all open windows are placed in the upper left corner of the screen.

You can position windows manually with the MOVE command.

## AdStops window (CMS only)

The AdStops window can only be opened when PER operation is active. It is opened by issuing the ADSTOPS command without providing any arguments. To close the window, issue the ADSTOPS command again without any arguments or issue the CLOSE command against that window. When the AdStops window is opened, it is positioned at the bottom right corner of the screen, and overlays any information there.

Alternatively, you can use the REGSTOPS command.

The AdStops window lets you set and reset register alteration stops (RegStops) or clear storage alteration stops (AdStops).

To clear a storage alteration stop, just place the cursor on the field describing the stop you want to clear, and either press the ERASE-EOF key or overtype the field with blanks. You must clear both the start and the end address.

Change the register stop settings by overtyping the values shown.

```
01-AdStops-----
PER Register Stop (RegStop) on:
R0 N R4 N R8 N R12 N
R1 N R5 N R9 Y R13 N
R2 N R6 N R10 N R14 N
R3 Y R7 N R11 N R15 N

PER Address Stop (AdStop) ranges:
1. 000202E0 (SUBJOB) @DL00101
   00020306 (SUBJOB) @DE00103
2. Free
   Free
3. Free
   Free
4. Free
   Free
```

Figure 1. AdStops window

## Additional Floating-Point Registers window

Open the Additional Floating-Point Registers window by issuing the AFPR command. Close the window by issuing the AFPR command again, or by issuing the CLOSE command against that window.

The window lists the active contents of the Floating-Point Control register, and the Additional Binary Floating-Point registers, that is, FPR1, 3, 5, 7 to 15.

You can change the contents of the registers by overtyping the hex values displayed.

```

02-Additional Floating Point Registers
Floating Point Control Register 00000000
FPR01 0000000000000000 FPR08 0000000000000000 FPR09 0000000000000000
FPR03 0000000000000000 FPR10 0000000000000000 FPR11 0000000000000000
FPR05 0000000000000000 FPR12 0000000000000000 FPR13 0000000000000000
FPR07 0000000000000000 FPR14 0000000000000000 FPR15 0000000000000000

```

Figure 2. An Example of the Additional Floating-Point Registers window

## Break window

Open the Break window by issuing the BREAK command without providing any arguments. Close the window by issuing the BREAK command again without any arguments or by issuing the CLOSE command against that window. When the Break window is opened, it is positioned at the top right corner of the screen, overlaying any existing information. It uses only as many rows as needed to display the breakpoint information.

The window lists the active breakpoints and watchpoints. For watchpoints, the address is preceded by a "w" and the condition are displayed on the next line. Any commands associated with the breakpoint or watchpoint are shown on the following line. If there are more breakpoints or watchpoints than fit on the screen the NEXT and PREVIOUS commands scroll forwards and backwards through the list.

The Break window also lets you clear breakpoints. Breakpoints remain in effect until you explicitly clear them.

To clear a breakpoint, place the cursor on the field describing the breakpoint you want to clear, and either press the ERASE-EOF key or overtype the field with blanks.

```

01-Current Registers      05-Break Points
(TCAT) @PROLOG+44      w00057752 (TCAT) @DL00029
R0 00009025 R1 0001    Condition: = c r3,=f'3'
R4 FEFE040F R5 FEFE    00057788 (TCAT) LOCRET
R8 FEFE080F R9 0005
R12 800576E0 R13 00012130 R14 000145CC R15 800576E0 FPR6 0000000000000000

02-Old Registers
(TCAT) @PROLOG+40      PSW 078D10008005771E (CC mask= 4 L)
0005771E 9620 C0BA      OI      CTGOPTN3,32
R0 00009025 R1 000120D4 R2 FEFE020F R3 FEFE030F FPR0 0000000000000000
R4 FEFE040F R5 FEFE050F R6 FEFE060F R7 FEFE070F FPR2 0000000000000000
R8 FEFE080F R9 000577BC R10 FEFE0A0F R11 FEFE0B0F FPR4 0000000000000000
R12 800576E0 R13 00012130 R14 000145CC R15 800576E0 FPR6 0000000000000000

03-Disassembly
(TCAT) @PROLOG+32
00057716 92C1 C0CA      MVI   CTGTYPE,193
0005771A 943F C0BA      NI    CTGOPTN3,63
0005771E 9620 C0BA      OI    CTGOPTN3,32
00057722 4190 07D8      LA    R9,2008
00057726 5090 C108      ST    R9,CATWRK
0005772A 1F88      SLR   R8,R8
0005772C 5080 C10C      ST    R8,CATWRKUS
00057730 4190 C108      LA    R9,CATWRK
00057734 5090 C0C4      ST    R9,CTGWKA
00057738 4170 0002      LA    R7,2

04-Storage Dump
(TCAT) CTGOPTN3
0005779A      21      .
(TCAT) CTGOPTN4
0005779B      00      .
(TCAT) CTGENT
0005779C 000577BC      ....
(TCAT) CTGCAT
000577A0 00000000      ....
(TCAT) CTGWKA
000577A4 00000000      ....
(TCAT) CTGDSORG

==>

1 Stmtstep   2 Regs       3 Quit        4 Until       5 Run         6 Dump
7 Previous   8 Next        9 Disasm     10 Break     11 Step      12 Retrieve

```

Figure 3. An Example of the Break window Overlaying other Windows

**CMS** The Break window lets you enable or disable SVC trapping and PER operation. Change the SVC and PER settings by overtyping the values shown.  
**CMS**

### Current Registers window

The Current Registers window is opened by entering the REGS command. It is closed by issuing the REGS command again or by issuing the CLOSE command against that window.

By default it displays the current PSW, the current general purpose and floating point registers. If the CREGS command was issued the current control registers are displayed. If the AREGS command was issued the current access registers are displayed.

You can modify the contents of the PSW or registers whenever they are displayed by overtyping the current information with the new value.

```

01-Current Registers-----
(TCAT) @PROLOG+84 PSW 078D20008005774A (CC mask=2 H)
R0 00009025 R1 000120D4 R2 00057FC0 R3 00000001 FPR0 0000000000000000
R4 FEFE040F R5 FEFE050F R6 00000001 R7 00000002 FPR2 0000000000000000
R8 00000000 R9 000577E8 R10 FEFE0A0F R11 FEFE0B0F FPR4 0000000000000000
R12 800576E0 R13 00012130 R14 000145CC R15 800576E0 FPR6 0000000000000000

```

Figure 4. Current Registers window, with General Purpose and Floating Point Registers

```

01-Current Registers-----
Access Registers: PSW 03E800008005774A (CC mask=2 H)
A0 00000000 A1 00000001 A2 00000000 A3 00000000
A4 00000000 A5 00000000 A6 00000000 A7 00000000
A8 00000000 A9 00000000 A10 00000000 A11 00000000
A12 00000000 A13 00000000 A14 00000000 A15 00000000

```

Figure 5. Current Registers window, with Access Registers

```

01-Current Registers-----
Control Registers: PSW 03E800008005774A (CC mask=2 H)
C0 000100E0 C1 00000000 C2 00000000 C3 00000000
C4 00000000 C5 00000000 C6 FF000000 C7 00000000
C8 00000000 C9 00000000 C10 00000000 C11 00000000
C12 00000000 C13 00000000 C14 1F000000 C15 00000000

```

Figure 6. Current Registers window, with Control Registers

## Disassembly window

Open a Disassembly window with the DISASM command or the OPEN DISASM command. Close it by issuing the DISASM command without an address or by issuing the CLOSE command against that window. Many Disassembly windows can be open. Each Disassembly window can display storage and source at a different address.

In a Disassembly window, instructions are shown disassembled to their approximate assembler syntax. You can change the contents of the locations displayed by overtyping the hex values shown on the left side of the screen. When storage that cannot be disassembled is displayed, up to 48 bytes (3 rows) are displayed in dump format in both hexadecimal and character form. The character form is EBCDIC unless the ASCII option is ON. Modify this storage by overtyping either the hexadecimal or the character portions. Characters overtyped in the character portion are EBCDIC unless the ASCII option is ON. If you have specified the PATH or PATHFILE options, a column of numbers is displayed at the right side of the screen. These numbers are execution counts for the instructions they are next to.

To change the location counter such that it reflects the original location counter of the CSECT as it appears in the assembler listing, use the OFFSET command to set the offset to the starting location of the CSECT within the modules. It may be necessary to set the OFFSET option on (use the OPTIONS command to review the current options).

CSECT names and external symbols are shown intensified (or in the heading color) and the next instruction to be executed is shown intensified (or in the message color). If a breakpoint was set for an instruction, then its address (at the left side of

## Windows and PF Keys

the screen) is shown intensified (or in the heading color). If a watchpoint was set for an instruction, then its address is shown intensified (or in the heading color) and is preceded by a 'w'. If an instruction starts a subroutine that is being skipped, then its address is shown intensified (or in the heading color) and is preceded by an 's'.

Branch instructions are disassembled to their appropriate extended mnemonics unless the NOBCX option is specified.

All open Disassembly windows share any space on the screen not occupied by the Additional Floating-Point Registers window, the Current Registers window, the Old Registers window, the Options window, and the Target Status window with any open Dump windows, and LSM Information windows. Use the SIZE and MOVE commands to change the size and location of any open window.

```
01-Disassembly
(RXLOCFN) RXLOCFN          RXLOCFN  CSECT
00057F88 47F0 F016          B      RXLOCFN+22
00057F8C 10D9              LPR    R13,R9
00057F8E      E7D3 D6C3C6D5 404040F8 F94BF1F9 | XLOCFN  89.19
00057F9C F400              | 4.
00057F9E 90EC D00C          STM    R14,R12,12(R13)
00057FA2 18CF          LR     R12,R15
00057FA4 1FFF          SLR    R15,R15
00057FA6 43F0 CBD4          IC     R15,RXLOCFN+3028
00057FAA 1F00          SLR    R0,R0
00057FAC BF07 CBD5          ICM    R0,B'0111',RXLOCFN+3029
00057FB0 18E0          LR     R14,R0
00057FB2 4100 0FF8          LA     R0,4088
00057FB6 190E          CR     R0,R14
00057FB8 47B0 C036          BNL   RXLOCFN+54
00057FBC 180E          LR     R0,R14
00057FBE 0700          NOPR
00057FC0 47F0 C040          B      RXLOCFN+64
00057FC4 00000200          | .....
00057FC8 89F0 0008          SLL   R15,8
00057FCC BFFD C03C          ICM    R15,B'1101',RXLOCFN+60
00057FD0 1B11          SR     R1,R1
00057FD2 0A78          SVC   120
00057FD4 1A10          AR     R1,R0
00057FD6 1B1E          SR     R1,R14
00057FD8 1B0E          SR     R0,R14
00057FDA 1300          LCR   R0,R0
00057FDC 58E0 D00C          L     R14,12(,R13)
00057FE0 5000 1000          ST    R0,0(,R1)
00057FE4 18B1          LR     R11,R1
00057FE6 50D0 B004          ST    R13,4(,R11)
00057FEA 50B0 D008          ST    R11,8(,R13)
00057FEE 98F1 D010          LM    R15,R1,16(R13)
00057FF2 18DB          LR     R13,R11
00057FF4 1871          LR     R7,R1
00057FF6 92E8 B064          MVI   100(R11),232
```

Figure 7. Disassembly window

## Dump window

Open a Dump window by issuing the DUMP command or the OPEN DUMP command. Close it by issuing the DUMP command without an address or by issuing the CLOSE command against that window. Many Dump windows can be open. Each Dump window can display storage at a different address. The Dump

window provides either a symbolic or an unformatted dump of storage. The dump format is toggled by the DUMPMODE command.

If a non-zero ALET was provided for a Dump window, then that window displays storage from the dataspace identified by the ALET. The storage in the dataspace is dumped in the unformatted style regardless of the current dump mode selected. The ALET specified is displayed on the first row of the Dump window.

You specify an ALET for a Dump window with the SET ALET command, by using an access register in an expression, or by placing the cursor in an access register in the Current Registers window or Old Registers window.

All open Dump windows share any space on the screen not occupied by the Additional Floating-Point Registers window, the Current Registers window, the Old Registers window, the Options window, and the Target Status window with any open Disassembly windows, and LSM Information windows. Use the SIZE and MOVE commands to change the size and location of any open window.

The symbolic format shows data areas with their symbolic names indicated. In addition, the symbolic dump format shows only the memory area that applies.

For example, if a variable is a halfword that is not aligned on a fullword boundary, IDF uses two lines to show it. The first line shows the CSECT and name of the variable. The second line shows the content of the variable in both hexadecimal and character formats. The character format is EBCDIC unless the ASCII option is ON. Since the variable is not aligned on a fullword boundary, the first two bytes of the word in which the variable is found are not shown, and the two bytes that are shown are shifted right on the screen by that amount.

The advantage of this dump format is that you see the variable and its limits, without hunting for them. The disadvantage is that less is shown on each screen, since a line is taken for each new variable's name.

```

01-Storage Dump
(ASMXDACP) ASMXDACP
0015FB18 47F0F0DE D3898385 95A28584 40D481A3 | ä00úLicensed Mat
0015FB28 85998981 93A24060 40D79996 978599A3 | erials - Propert
0015FB38 A8409686 40C9C2D4 40C1E2D4 D3C1D5C7 | y of IBM ASMLANG
0015FB48 E7404DC3 5D40C396 97A89989 8788A340 | X (C) Copyright
0015FB58 C9C2D440 F1F9F9F5 4B40C193 9340D989 | IBM 1995. All Ri
0015FB68 8788A3A2 40D985A2 8599A585 844B40E4 | ghts Reserved. U
0015FB78 E240C796 A5859995 948595A3 40E4A285 | S Government Use
0015FB88 99A240D9 85A2A399 8983A385 8440D989 | rs Restricted Ri
0015FB98 8788A3A2 406040E4 A2856B40 84A49793 | ghts - Use, dupl
0015FBA8 898381A3 89969540 96994084 89A28393 | ication or discl
0015FBB8 96A2A499 85409985 A2A39989 83A38584 | osure restricted
0015FBC8 4082A840 C7E2C140 C1C4D740 E2838885 | by GSA ADP Sche
0015FBD8 84A49385 40C39695 A3998183 A340A689 | dule Contract wi
0015FBE8 A38840C9 C2D440C3 9699974B 400007FE | th IBM Corp. ..Ú
(ASMXMAIN) ASMXMAIN
0015FBF8 47F0F016 10C1E2D4 E7D4C1C9 D54040F9 | ä00..ASMXMAIN 9
0015FC08 F54BF2F9 F60090EC D00C18CF 41B0CFFF | 5.296.°0}..ö [ö.
0015FC18 47F0C028 00163FF8 5870C024 58007690 | ä0{...8iø{.i.Î°
0015FC28 181D1B10 5A00D000 47D0C040 00000002 | ....|.}.ä}{ ....
0015FC38 50001000 D20F1048 D04818FD 18D150F0 | &...K..ç|ç.Û.J&0
0015FC48 D00450D0 F00898F1 F010D203 D0581000 | }.&}0.q10.K.†i..
0015FC58 5860D058 58806000 5080D100 58A0D050 | i-}iï0-.&ØJ.ifff&
0015FC68 4120D212 5020A160 D70C2000 20004190 | .K.&...-P.....°
0015FC78 D2835090 A164D779 90009000 4130A110 | Kc&°.ÄP..°.°. ".

```

Figure 8. Formatted Dump window

The unformatted dump provides the "traditional" memory dump display.

```

01-Storage Dump
0015FB18 47F0F0DE D3898385 95A28584 40D481A3 | à00úLicensed Mat
0015FB28 85998981 93A24060 40D79996 978599A3 | erials - Propert
0015FB38 A8409686 40C9C2D4 40C1E2D4 D3C1D5C7 | y of IBM ASMLANG
0015FB48 E7404DC3 5D40C396 97A89989 8788A340 | X (C) Copyright
0015FB58 C9C2D440 F1F9F9F5 4B40C193 9340D989 | IBM 1995. All Ri
0015FB68 8788A3A2 40D985A2 8599A585 844B40E4 | ghts Reserved. U
0015FB78 E240C796 A5859995 948595A3 40E4A285 | S Government Use
0015FB88 99A240D9 85A2A399 8983A385 8440D989 | rs Restricted Ri
0015FB98 8788A3A2 406040E4 A2856B40 84A49793 | ghts - Use, dupl
0015FBA8 898381A3 89969540 96994084 89A28393 | ication or discl
0015FBB8 96A2A499 85409985 A2A39989 83A38584 | osure restricted
0015FBC8 4082A840 C7E2C140 C1C4D740 E2838885 | by GSA ADP Sche
0015FBD8 84A49385 40C39695 A3998183 A340A689 | dule Contract wi
0015FBE8 A38840C9 C2D440C3 9699974B 400007FE | th IBM Corp. ..Ú
0015FBF8 47F0F016 10C1E2D4 E7D4C1C9 D54040F9 | à00..ASMXMMAIN 9
0015FC08 F54BF2F9 F60090EC D00C18CF 41B0CFFF | 5.296.°Ö}..õ [õ.
0015FC18 47F0C028 00163FF8 5870C024 58007690 | à0{...8iø{.i.İ°
0015FC28 181D1B10 5A00D000 47D0C040 00000002 | ....|.}.ã}{....
0015FC38 50001000 D20F1048 D04818FD 18D150F0 | &...K..ç|ç.Ü.J&0
0015FC48 D00450D0 F00898F1 F010D203 D0581000 | |.&|0.q10.K.|i..
0015FC58 5860D058 58806000 5080D100 58A0D050 | i-}i i0-.&0J.iff}&
0015FC68 4120D212 5020A160 D70C2000 20004190 | .K.&.r-P..... °
0015FC78 D2835090 A164D779 90009000 4130A110 | Kc&°rÄP°L°.°.r.
0015FC88 5030D0D4 58F07278 4110D0D4 05EF4130 | &.)Mî0ÈI .}M.Ö .
0015FC98 90585030 D0D458F0 727C4110 D0D405EF | °i&.)Mî0È0 .}M.Ö
    
```

Figure 9. Unformatted Dump window

Regardless of the dump format, you can modify memory by overtyping the data shown, in either the hexadecimal or the character portions of the display. Characters overtyped in the character portion are EBCDIC unless the ASCII option is ON.

### LSM Information window

Open an LSM Information window after IDF Language extract data is loaded. Open it with an ARRAY, STRUCTURE, or VARIABLE command, a LANGUAGE command that causes IDF to open this window, or the OPEN command. Close it with an ARRAY, STRUCTURE, or the VARIABLE command without any arguments or by issuing the CLOSE command against that window. Many LSM Information windows can be opened. Each LSM Information window can display different information.

All open LSM Information windows share any space on the screen not occupied by the Additional Floating-Point Registers window, the Current Registers window, the Old Registers window, the Options window, and the Target Status window with any open Disassembly windows, and Dump windows. Use the SIZE and MOVE commands to change the size and location of any open window.

The title and contents of an LSM Information window varies depending on the command being used and the IDF Language options and settings.

```

Var: BThing          > This is the b-thing here          <
    
```

Figure 10. LSM Information window, with VARIABLE command output. In this case, the variable attributes are hidden due to the COMPACT ON (default) Language option.

```

01-Language Options-----
Show: Both, Stmt
Dcls: ON      Comments: ON      Macs: ON      Generated: ON      Nocode: OFF
Space: OFF    Brief: OFF      Compact: OFF
Char: EBCDIC  Fixed: Decimal  Float: Std     Bit: Bit
Enum: Decimal Packed: Decimal  Zoned: Decimal
VAR checking: Bounds: ON      Negative: ON      Substring: ON      Optimize: ON
Audit: OFF
SAREGS: OFF  SALIMIT: 100
Major: OFF   PadID: OFF      Detail: MIN,3
Nest: 0      Scroll: MAX
Debug: OFF
Stem: LSM.           EXLIMIT: 20000
XPATH: ASMLANGX
    
```

Figure 11. LSM Information window, with LANGUAGE OPTIONS command output

## Minimized Windows Viewer

The MINIMIZE command "shrinks" a window, and so frees up space on the display screen. The first MINIMIZE command opens the Minimized Windows Viewer below the Command window (command line and PF Keys). An entry representing the minimized window is placed in the Minimized Windows Viewer. You can select the window to be minimized with the cursor.

The MAXIMIZE command restores a minimized window to its previous position on the display screen. When the last minimized window is maximized, the Minimized Windows Viewer closes. You can select the window to be maximized with the cursor.

```

01-Current Registers-----
(TCAT) @PROLOG+44                               PSW 078D100080057722 (CC mask=4 L)
R0 00009025 R1 000120D4 R2 FEFE020F R3 FEFE030F FPR0 0000000000000000
R4 FEFE040F R5 FEFE050F R6 FEFE060F R7 FEFE070F FPR2 0000000000000000
R8 FEFE080F R9 000577BC R10 FEFE0A0F R11 FEFE0B0F FPR4 0000000000000000
R12 800576E0 R13 00012130 R14 000145CC R15 800576E0 FPR6 0000000000000000
02-Disassembly-----
(TCAT) @PROLOG+32
00057716 92C1 C0CA                               MVI  CTGTYPE,193
0005771A 943F C0BA                               NI   CTGOPTN3,63
0005771E 9620 C0BA                               OI   CTGOPTN3,32
00057722 4190 07D8                               LA   R9,2008
00057726 5090 C108                               ST   R9,CATWRK
0005772A 1F88                                   SLR  R8,R8
0005772C 5080 C10C                               ST   R8,CATWRKUS
00057730 4190 C108                               LA   R9,CATWRK
00057734 5090 C0C4                               ST   R9,CTGWKA
00057738 4170 0002                               LA   R7,2

==>

1 Stmtstep  2 Regs      3 Quit      4 Until     5 Run       6 Dump
7 Previous  8 Next        9 Disasm    10 Break    11 Step     12 Retrieve
    
```

Figure 12. A sample screen before any windows are minimized

```

01-Current Registers-----
(TCAT) @PROLOG+44                PSW 078D100080057722 (CC mask=4 L)
R0 00009025 R1 000120D4 R2 FEFE020F R3 FEFE030F FPR0 0000000000000000
R4 FEFE040F R5 FEFE050F R6 FEFE060F R7 FEFE070F FPR2 0000000000000000
R8 FEFE080F R9 000577BC R10 FEFE0A0F R11 FEFE0B0F FPR4 0000000000000000
R12 800576E0 R13 00012130 R14 000145CC R15 800576E0 FPR6 0000000000000000

==>

1 Stmtstep  2 Regs      3 Quit      4 Until     5 Run      6 Dump
7 Previous  8 Next      9 Disasm   10 Break   11 Step    12 Retrieve
MIN-> 02-Disasm
    
```

Figure 13. The same screen after the Disassembly window is minimized

## Options window

Open an Options window with the `OPTIONS` command. Close it by issuing the `OPTIONS` command again, or by issuing the `CLOSE` command against that window.

The Options window has a fixed size. Use the `PREVIOUS` and `NEXT` commands or PF keys to scroll to the next or previous page of settings, provided the cursor is in the Options window when the command is issued or PF key pressed.

Some IDF options settings cannot be modified after IDF has completed initialization. For these, the option setting is shown in the same color as the option name.

Modify the remaining options by overtyping the current setting with an appropriate options keyword.

```

04-Debugger Options-----More: + -
APROGMSG: ON  ASCii: OFF  AUTOLoad: ON  AUTOSize: ON  BCX: ON
CKSubcm: OFF  CMDLog: OFF  CMPExit: OFF  COMmand: OFF  DMS0: OFF
DSEctS: ON   EXItexec: OFF  FASTPath: OFF  FULLQual: OFF  HEXDisp: ON
HEXInput: ON  IMPMacro: ON   INVPSw: OFF  MACROLog: OFF  MODMap: ON
    
```

Figure 14. Options window

## Old Registers window

Open the Old Registers window with the `OREGS` command. Close it by issuing the `OREGS` command again or by issuing the `CLOSE` command against that window. If your program has executed one or more instructions, by default, a copy of the PSW, next instruction, and registers as of the last time IDF was in control are also shown (after this these are generally the previous contents of the PSW, general registers, and so on). If the `CREGS` command or the `AREGS` command was

issued, the control registers or the access registers, respectively, as of the last time IDF was in control are displayed. If your program has not executed any instructions, this window is empty.

```

01-Old Registers
(TCAT) @PROLOG+82                PSW 078D200080057748 (CC mask=2 H)
00057748 1836                      LR   R3,R6
R0 00009025 R1 000120D4 R2 00057FC0 R3 FEFE030F FPR0 0000000000000000
R4 FEFE040F R5 FEFE050F R6 00000001 R7 00000002 FPR2 0000000000000000
R8 00000000 R9 000577E8 R10 FEFE0A0F R11 FEFE0B0F FPR4 0000000000000000
R12 800576E0 R13 00012130 R14 000145CC R15 800576E0 FPR6 0000000000000000

```

Figure 15. Old Registers window

## Skipped Subroutines window

Open the Skipped Subroutines window by issuing the SKIPSTEP command without providing any arguments. Close the window, by issuing the SKIPSTEP command again without any arguments or issue the CLOSE command against that window. When the Skipped Subroutines window is opened, it is positioned at the top right corner of the screen, overlaying any existing information. It uses as many rows as needed to display the information.

The window lists the subroutines for which single-stepping, statement stepping, or the PATH or FASTPATH options are bypassed. If there are more skipped subroutines than fit on the screen, the NEXT and PREVIOUS commands scroll forward and backward through the list.

The Skipped Subroutines window also lets you stop the "skipping" of a subroutine by placing the cursor on the field describing the subroutine in question, and either pressing the ERASE-EOF key or overtyping the field with blanks.

```

01-Subroutines Skipped
00057712 (RXLLSTDD) XCOM
00057A88 (RXLLISTD) RXLLISTD

```

Figure 16. Skipped Subroutines window

## Target Status window

Open the Target Status window with the STATUS command. Close it by issuing the STATUS command again or by issuing the CLOSE command against that window. The Target Status window provides information about the programs known to IDF. This includes the number of symbols in the program known to IDF, where the program was loaded in memory, how large it is, and, for the original target, its entrypoint address. The name of the currently qualified module is shown in the message color. The window shows the information about one module at a time. To display information about the other modules known to IDF, place the cursor in the Target Status window and issue a NEXT or PREVIOUS command.

```

Program VARMVXA Origin 00057920 Entrypoint 80057920
Symbols 66          End 00057FFF Size(hex) 000006E0 Size(dec) 1760

```

Figure 17. Target Status window

## Some Examples of Actual Screens

Different windows can be open at the same time in various combinations. The larger the screen the more windows you can have open at one time. The figure below shows a combination of open windows. It combines the Current Registers window, the Old Registers window, a Disassembly window and a Dump window all on one screen. The example was created on a screen with 43 lines.

```

01-Current Registers-----
(TCAT) @PROLOG+44                               PSW 078D100080057722 (CC mask=4 L)
R0 00009025 R1 000120D4 R2 FEFE020F R3 FEFE030F FPR0 0000000000000000
R4 FEFE040F R5 FEFE050F R6 FEFE060F R7 FEFE070F FPR2 0000000000000000
R8 FEFE080F R9 000577BC R10 FEFE0A0F R11 FEFE0B0F FPR4 0000000000000000
R12 800576E0 R13 00012130 R14 000145CC R15 800576E0 FPR6 0000000000000000
02-Old Registers-----
(TCAT) @PROLOG+40                               PSW 078D10008005771E (CC mask= 4 L)
0005771E 9620 C0BA                               OI   CTGOPTN3,32
R0 00009025 R1 000120D4 R2 FEFE020F R3 FEFE030F FPR0 0000000000000000
R4 FEFE040F R5 FEFE050F R6 FEFE060F R7 FEFE070F FPR2 0000000000000000
R8 FEFE080F R9 000577BC R10 FEFE0A0F R11 FEFE0B0F FPR4 0000000000000000
R12 800576E0 R13 00012130 R14 000145CC R15 800576E0 FPR6 0000000000000000
03-Disassembly-----
(TCAT) @PROLOG+32
00057716 92C1 C0CA                               MVI  CTGTYPE,193
0005771A 943F C0BA                               NI   CTGOPTN3,63
0005771E 9620 C0BA                               OI   CTGOPTN3,32
00057722 4190 07D8                               LA   R9,2008
00057726 5090 C108                               ST   R9,CATWRK
0005772A 1F88                               SLR  R8,R8
0005772C 5080 C10C                               ST   R8,CATWRKUS
00057730 4190 C108                               LA   R9,CATWRK
00057734 5090 C0C4                               ST   R9,CTGWKA
00057738 4170 0002                               LA   R7,2
04-Storage Dump-----
(TCAT) CTGOPTN3
0005779A 21                                     .
(TCAT) CTGOPTN4
0005779B 00                                     .
(TCAT) CTGENT
0005779C 000577BC                             ....
(TCAT) CTGCAT
000577A0 00000000                             ....
(TCAT) CTGWKA
000577A4 00000000                             ....
(TCAT) CTGDSORG

==>
1 Stmtstep  2 Regs      3 Quit      4 Until    5 Run      6 Dump
7 Previous  8 Next      9 Disasm   10 Break   11 Step    12 Retrieve
    
```

Figure 18. An Example of Several Open Windows on One Screen

If your screen display is similar to the one shown above, and you open the Break window, the Break window overlays part of the screen as described above and shown in Figure 19 on page 71.

```

01-Current Registers-----05-Break Points-----
(TCAT) @PROLOG+44          w00057752 (TCAT) @DL00029
R0 00009025 R1 0001          Condition: = c r3,=f'3'
R4 FEFE040F R5 FEFE          00057788 (TCAT) LOCRET
R8 FEFE080F R9 0005
R12 800576E0 R13 00012130 R14 000145CC R15 800576E0 FPR6 0000000000000000

02-Old Registers-----
(TCAT) @PROLOG+40          PSW 078D10008005771E (CC mask= 4 L)
0005771E 9620 C0BA          OI      CTGOPTN3,32
R0 00009025 R1 000120D4 R2 FEFE020F R3 FEFE030F FPR0 0000000000000000
R4 FEFE040F R5 FEFE050F R6 FEFE060F R7 FEFE070F FPR2 0000000000000000
R8 FEFE080F R9 000577BC R10 FEFE0A0F R11 FEFE0B0F FPR4 0000000000000000
R12 800576E0 R13 00012130 R14 000145CC R15 800576E0 FPR6 0000000000000000

03-Disassembly-----
(TCAT) @PROLOG+32
00057716 92C1 C0CA          MVI   CTGTYPE,193
0005771A 943F C0BA          NI    CTGOPTN3,63
0005771E 9620 C0BA          OI    CTGOPTN3,32
00057722 4190 07D8          LA    R9,2008
00057726 5090 C108          ST    R9,CATWRK
0005772A 1F88          SLR   R8,R8
0005772C 5080 C10C          ST    R8,CATWRKUS
00057730 4190 C108          LA    R9,CATWRK
00057734 5090 C0C4          ST    R9,CTGWKA
00057738 4170 0002          LA    R7,2

04-Storage Dump-----
(TCAT) CTGOPTN3
0005779A          21          .
(TCAT) CTGOPTN4
0005779B          00          .
(TCAT) CTGENT
0005779C 000577BC          ....
(TCAT) CTGCAT
000577A0 00000000          ....
(TCAT) CTGWKA
000577A4 00000000          ....
(TCAT) CTGDSORG

==>

1 Stmtstep   2 Regs       3 Quit       4 Until     5 Run       6 Dump
7 Previous   8 Next       9 Disasm    10 Break    11 Step     12 Retrieve

```

Figure 19. An Example of the Break window Overlaying other Windows

## Specifying a Window

Many commands affect what is displayed in a particular window. There can be more than one Disassembly window, Dump window, or LSM Information window, open at once. IDF needs to be told which one is the target of commands like DISASM, DUMP, FOLLOW, LANGUAGE, SEARCH, and SET ALET. Similarly, with the CLOSE, MOVE, NEXT, PREVIOUS, and SIZE commands IDF needs to be told which window to use.

To tell IDF which window to use, you can use a Window Specification in the appropriate command. The Window Specification is an equal sign followed by the window's window number, in the form "=n". The Window Specification, if present, must precede any operands of the command. For example:

```
DISASM =2 address
FOLLOW =3 R9
```

You can also indicate the window IDF should use by placing the cursor in the window. As the cursor can also specify the argument of a command, a Window

## Windows and PF Keys

Specification, if present, is used in preference to the position of the cursor to specify the window to be used.

If you neither use a Window Specification nor place the cursor in a window of the appropriate type (Disassembly window for DISASM command, and so on), then:

1. The DISASM and LANGUAGE commands use the first open Disassembly window.
2. The DUMP and FOLLOW commands use the first open Dump window.
3. The ARRAY, STRUCTURE, and VARIABLE commands use the first open LSM Information window.
4. The NEXT and PREVIOUS commands scroll all the open windows.
5. The SIZE and MOVE commands need the window type as an extra argument.
6. The SEARCH command starts searching from the start address of the first open Disassembly window or Dump window.

---

## PF Keys

The default PF key settings provide the functions anticipated to be most useful.

As distributed on CMS and TSO, the ENTER key is set to the COMMAND command. This means that you can invoke any IDF command by typing it on the command line and pressing ENTER, instead of invoking it by pressing a PF key.

You can redefine the PF keys by issuing a SET command on the command line, by issuing SET commands in your PROFILE (the usual method), or by writing a macro to reset them (occasionally useful). The SET PFK command is described in "PFK" on page 158.

The ENTER key and PF1 through PF24 can be set to any IDF command or to any IDF macro.

By default, PF13 through PF24 are undefined and undisplayed. To display use "PFKDISP" on page 158. Any of those keys that remain undefined are mapped into PF1 through PF12. This makes it easier to use some terminals.

---

## Command Record and Playback Features

IDF provides a command level record and playback facility. IDF records commands to a command log. These commands can then be replayed. They can all be replayed at the start of a debugging session, or else they can be recalled one by one, and then executed, modified and executed, or skipped.

To record a debugging session on the command level, specify or set the CMDLOG option.

The location of the command log is:

- On CMS, the file "ASM CMDLOG *fm*", where *fm* is specified by the MODE option (and defaults to file mode A1).
- On TSO, the dataset defined by the CMDLOG DD name.
- On VSE, the dataset defined by the CMDLOGO DLBL name.

Turn logging off with the SET OPTION CMDLOG command.

You can specify command arguments with the cursor position, and you can overwrite data on the screen. IDF logs all operations in a way that lets you repeat them later.

To play back all or part of a session recorded at command level, use the RLOG command, or specify the RLOG option at invocation.

---

## Address Expressions

You can specify the addresses you provide to IDF either by the cursor placement (for information about this see "Arguments and Cursor Positioning" on page 75) or by typing an expression on the command line before pressing a PF key.

An IDF expression is made up of terms. If an expression consists of two or more terms, a plus (+) or minus (-) sign (operator) indicates that the fully resolved values of the terms should be added or subtracted.

A term can consist of a program symbol, a statement number, a hex constant, a decimal constant, or a character constant that is one character in length. The following are examples of basic terms:

```

LOOP
STMT#5
X'2005E'
C'b'
247
F'235'

```

Source statement numbers can be used as symbolic names. They are specified in the form "STMT#*nnnn*", where *nnnn* is the statement number involved.

Numeric values that are input without an explicit hexadecimal (X'999') or decimal (F'999') indication, for example "246", are interpreted by IDF as determined by the current base setting. The default base is decimal. It can be redefined to hexadecimal with HEXINPUT ON or SET OPTION ON HEXINPUT. (The arrow beside the command line indicates the default base; an arrow of the form "-->" is used if the default base is decimal, and of the form "=>" is used if the default base is hex.)

Implicitly specified hexadecimal numbers must begin with a numeric digit from 0 to 9. If you attempt to input a hexadecimal number such as A34 implicitly, IDF interprets it as the name of a symbol, not a number. Thus, 0A34 is recognized (assuming the default base is hexadecimal) but A34 is taken as a symbol name.

In some cases you may wish to specify a CSECT name or a module name. For example, if symbol LOOP occurs in two assemblies, you have to specify the CSECT name of the symbol you are referring to. If the symbol is not in the currently QUALIFIED module, you have to specify the module of the symbol you are referring to. Specify the module name and the CSECT name by prefixing the term with them, and enclosing them in parentheses. The module name, when present, precedes the CSECT name and is followed by a period. When a module name is specified, a CSECT name need not be specified. Here are some examples:

## Address Expressions

```
(TEST)LOOP
(VARMVSXA.VARASM) BTHING
(TCAT.) LOCRET
```

Intersperse blanks as you like, provided they do not interrupt items such as a symbol or hex constant. For example, the following expressions are equivalent to the previous ones:

```
( TEST )      LOOP
( VARMVSXA . VARASM ) BTHING
( TCAT . ) LOCRET
```

The SET QUALIFY command tells IDF which module's symbols should be searched when a module name is not specified in a symbolic name.

In some cases you may wish to follow a term with a register designator. A register designator consists of the strings 'PSW', 'R0' through 'R15', or 'AR0' through 'AR15', enclosed in parentheses. If 'AR0' through 'AR15' are specified then those commands that can use an ALET use the ALET contained in that access register in addition to the contents of the associated general purpose register. For example, location LOOP in CSECT TEST indexed by the current contents of R4 is specified:

```
(TEST)LOOP(R4)
```

The byte at the location addressed by R4 in the dataspace identified by the ALET in AR4 is specified:

```
0(AR4)
```

You can combine terms, for example:

```
(TEST) LOOP+20 (R2)

24(R2)+0(R3)
```

As another example, to find the difference between two labels in the same CSECT, LOOP and LOOPEND, you could use:

```
(TEST)LOOPEND-(TEST)LOOP
```

If you have a translate table, you might want to use an expression with a character term:

```
TRTABLE+C't'
```

Character terms in addressing expressions are restricted to a single character. If you need to specify an apostrophe, place two apostrophes within the enclosing apostrophes: for example C''''.

Terms and register designators can be followed by indirection operators (% , :> , ? , => , ->). If an indirection operator follows a term, IDF uses the contents of the word pointed to by the expression evaluated thus far. Similarly, if an indirection operator follows a register designator, IDF is being told how to interpret the contents of the register. The word or register is treated as:

- A 24-bit address if the % or :> operators are used.
- A 31-bit address if the ? or => operators are used.
- The appropriate size (31-bit or 24-bit) depending on the AMODE of the PSW if the -> operator was used.

**Note:** If a register designator is not followed by an indirection operator it is interpreted as a 31-bit or 24-bit value depending on the AMODE of the PSW. You can refer to the current offset value (set with the OFFSET command) by starting an expression with a unary plus or minus. If the expression begins with a unary plus, it is interpreted as the current OFFSET value plus the remainder of the expression. If the expression begins with a unary minus, it is interpreted as the current OFFSET value minus the remainder of the expression. Examples of an expression of this type are:

```
+X'40'  
-23
```

If the current offset value is X'20000', the expression +X'40' gives the value X'20040'.

---

### Addresses Displayed by IDF

In many situations IDF displays, or returns, addresses in symbolic form. Normally, these "symbolic addresses" are of the form "(module.csect) symbol+offset". If the address is within a code section for which IDF Language extract data was loaded, the symbolic address is of the form:

```
"(module.csect) STMT#nnnnn+offset".
```

If the address is within the limits of the currently qualified module, the module name and the separating period are normally left out. The FULLQUAL option forces IDF to always include the module name in generated symbolic names.

Source statement numbers can be used as symbolic names. They are specified in the form "STMT#nnnnn", where nnnnn is the statement number involved. nnnnn can be any value between 1 and 65535 inclusive.

---

### Arguments and Cursor Positioning

A number of IDF commands accept arguments. For example, the BREAK command accepts an argument, which is the address at which a breakpoint is to be set. This section describes the method used by IDF to determine what argument was provided.

IDF uses "intelligent" cursor sensing logic to let you specify a "verb" by pressing a PF key, and specify the argument by either typing an expression, or "pointing" with the cursor. Instead of typing an expression and a command, you can place the cursor on a display field, then press a PF key. This tells IDF to perform the requested task at the current cursor location.

The following examples show how this works in practice:

- When a register contains the address of an area you want to dump or disassemble, place the cursor in the register and press the DUMP or DISASM PF key.
- If a Disassembly window is open, you can place the cursor in the first input field where the instruction's hexadecimal value is shown, and press the BREAK key to set a breakpoint on that instruction.
- If you have dumped a control block that contains a "link" word, place the cursor in the link word and press the DUMP key. This makes the link word the

## Arguments and Cursor Positioning

first one shown. If you press DUMP again, IDF "follows" the link and displays the next control block.

- If you have dumped a storage area that is being altered unintentionally, you can place the cursor in the Dump window and issue the ADSTOPS command to set the start of an address modification range, then move the cursor to the end of the area and issue the ADSTOPS command again to set the end of the range.

If you find the rules described here difficult to remember, experiment with IDF to see if you can get the "feel" of it. If not, you can always specify arguments by typing them on the command line.

Here is how IDF determines the argument:

1. If the command does not accept an argument, no argument is sought.
2. If an expression is entered on the command line, that expression is evaluated as the supplied argument.
3. If the cursor is on the command line, but no expression is entered there, IDF considers that no argument is supplied.
4. If the cursor is in an unprotected field that is not the command line, IDF attempts to use that cursor position as an indication of the argument that the operator needs, as follows:
  - a. If the cursor is in a floating-point register, or any field shown on the Break window, IDF considers that no argument is supplied.
  - b. If the cursor is in a general-purpose register, IDF considers the low-order 24 bits, or the low-order 31 bits if in AMODE-31, of the contents of that register is the supplied argument. If the access registers are displayed, then the DUMP and OPEN DUMP commands use the ALET contained in the access register in addition to the address contained in the associated general-purpose register. This applies to the registers displayed in both the Current Registers window and the Old Registers window.
  - c. If the cursor is in the PSW, IDF considers the address part of the PSW is the supplied argument. This applies to the PSW displayed in both the Current Registers window and the Old Registers window.
  - d. If the cursor is in a disassembled instruction, the following rules apply:
    - 1) All commands except DISASM and OPEN DISASM use the address of the halfword the cursor is in.
    - 2) The DISASM and OPEN DISASM commands use the address of the halfword the cursor is in, *unless* the field the cursor is in is both the first field disassembled and a branch instruction, when the commands use the effective address of the branch instruction.
  - e. If the cursor is in the protected portion of a disassemble line, the starting address of the instruction disassembled is used.
  - f. If the cursor is in a dump field, the following rules apply:
    - 1) All commands except DUMP and OPEN DUMP use the address of the beginning of the hexadecimal field the cursor is in, or the exact address of the character the cursor is on if it is in the character portion of the display.

- 2) The DUMP and OPEN DUMP commands use the address of the beginning of the hexadecimal field the cursor is in, *unless* the field is both a fullword field and the first field in the dump display, in which case the commands use the low-order 24 bits, or the low-order 31 bits if in AMODE-31, of the *contents* of the field.
- g. If the cursor is in the protected portion of a dump line, the starting address of the dump line is used.

---

## Chapter 9. Source-Level Debug Additional Capabilities

IDF provides a significant debug capability for application programs at the disassembly (object code) level without any more preparation. For trivial debug situations, this is often enough.

Programmers write programs at the source level. It follows that when the reason for a problem is not immediately visible, it is advantageous to also debug at the source level. The addition of the ASMLANGX step to the program development process means that IDF Language extract data is available for the program compile units. When this data is loaded using the IDF LOAD LANGUAGE or STEP or STMTSTEP commands, you can perform these extra functions:

- Selectively enable and disable the display of variable declaration statements with SHOW DCLS and HIDE DCLS commands.
  - Selectively enable and disable the display of block comments with SHOW COMMENTS and HIDE COMMENTS commands.
  - Selectively enable and disable the display of macro definitions and macro expansions with SHOW MACROS and HIDE MACROS commands.
  - Perform source text searches
    - You can find and display the desired area of the source code.
    - The search can be up or down.
    - Both LOCATE (similar to the XEDIT Locate command) and FIND (similar to the ISPF Editor Find command) commands are supported.
  - Set breakpoints on program statements
    - The breakpoint can be at the start of, or within, any program statement.
  - Single-step your program
    - You can use the STMTSTEP command to single-step at the program statement level.
    - You can use the STEP command to single-step at the program instruction level.
  - Program variable data display (with optional typeover alteration)
    - Supported for any program variable that is "known" in the currently executing program block.
    - There are many types of variables. These are displayed with different IDF Language Support commands:
      - To display simple variables, the VARIABLE command is used.
      - To display structures and their components, the STRUCTURE command is used.
      - To display array elements, the ARRAY command is used.
      - To display variables type attributes, the TYPE command is used.
      - To display the names of variables for which a pointer (or locator) variable is a valid base address, the PLOCATES command is used.
- For more details, see “Displaying and Changing Items” on page 80.

- The various forms of program variable display support complex expressions. See “Variable Expressions” on page 81 for more details.
  - Program variable name display
    - The names of the program variables matching a particular pattern can be displayed.
    - The names of all program variables can be displayed.
- See “Displaying Variable Names” on page 84 for more details.
- Program caller hierarchy display
    - For each generation:
      - For those programs for which IDF Language information is available, the program module, code section, source statement number, and source statement number are shown
      - For those programs without IDF Language information, the program module, code section, and offset from the start of this code section are shown.

See “Displaying CALLERS” on page 84 for more details.

---

## Controlling Single-stepping your Program

If STOPSTMT OFF is in effect, the ASMLANGX data is not automatically loaded while the STMTSTEP process is in control. If STOPSTMT OFF is in effect when STMTSTEP is at a code location for which no extract data is loaded, then language extract AUTOLOAD is not performed. At the start of the session with no LAN LOA done, when the STMTSTEP is issued - it will load the extract data for the current CSECT and then go into STMTSTEP process mode. Once in this process no further loads will occur. This allows for all CSECTS to have language extract data available at all times. When running a debug session in which only particular CSECTS are to be examined by STMTSTEPping, then set STOPSTMT OFF and LAN LOA the CSECTS required prior to starting - there is no need to manipulate the members available in the ASMLANGX dataset.

With STOPSTMT OFF, a STMTSTEP on a call to another CSECT will still perform single-stepping on each instruction in the called routine (without updating the display) until an instruction for which language extract data was loaded is encountered. This may involve many thousands of instructions before such an instruction is encountered, and may give the appearance that the program is in a loop because the display is locked during this process.

If the STEP command is issued by a macro, it does not take effect until the macro exits. The MSTEP command can be used to execute target instructions before returning control to the invoking macro.

If you have subroutines within the program which you do not want to step through, use the SKIPSTEP command. The SKIPSTEP command causes IDF to skip stepping when it comes to a subroutine call to a subroutine that was added to the list of subroutines being skipped. For the purposes of stepping, the skipped subroutine is treated as one instruction, the subroutine call instruction itself. If a breakpoint or a watchpoint whose condition is true is placed within the execution

## Displaying and Changing Items

path of the subroutine being skipped, execution stops at that breakpoint or watchpoint.

---

## Displaying and Changing Items

Items are displayed using these commands:

---

*Table 1. Commands Displaying Items*

---

<b>Item</b>	<b>Command</b>
variables	VARIABLE
structures	STRUCTURE
array elements	ARRAY
type attributes for a variable	TYPE
pointer locates information for a variable	PLOCATES

---

The VARIABLE command lets you look at successive elements of an array. However, the need to manually update the array indices to view the desired array element becomes tiresome.

If the array is a structure component, use the STRUCTURE command to scroll through all elements of the array.

If the array is actually a substructure with multiple components you must spend the time to scroll past the components which are not relevant to the problem at hand. The ARRAY command helps in these situations.

When you use the ARRAY command, you select the initial element to be displayed using the same syntax as the VARIABLE command. The significant differences are:

- When the LSM Information window is scrolled forwards past the end of the current variable information display, the next element in the array is displayed.
- When the LSM Information window is scrolled backwards past the beginning of the current variable information display, the previous element in the array is displayed.

The display of the information about items persists until you:

- Issue the same command, but without item arguments.
- Issue a CLOSE command against the window.
- Update the information in the window, with a command such as VARIABLE, ARRAY, CALLERS, EVALUATES, PLOCATES, LANGUAGE STATUS or MAP.
- The target program completes execution.
- The target program execution progresses beyond the item's defined scope.

You can change the data displayed by a VARIABLE, STRUCTURE, UNION or ARRAY command by overtying it.

## Variable Expressions

Variable expressions are supported for those programs for which the program that generates the extraction file (ASMLANGX) has made variable information available. Variables are displayed in PL/I-like format, with appropriate extensions where needed.

Variable expressions cannot be substituted for Address expressions in commands that expect an address to be supplied. For example, 'BREAK variable-expression' does not evaluate the variable-expression as an address. However, an IDF macro can be written that makes use of EXTRACT VLOC to determine the address of a variable which is then used as an operand on any IDF command:

```

/* REXX Variable Breakpoint                               */
/* Supply the variable name to be set breakpoint at */
ARG vbn
  IF vbn ^= '' THEN DO
    'EXTRACT VLOC ' vbn
    IF LSM.0 = 1 THEN DO
      PARSE VAR LSM.1 . varaddr .
      'BREAK 'varaddr
    END
  END
END

```

## Variable Scope

The source statement which corresponds to the current instruction address in the PSW is used to determine the current program scope.

Only variables that are active within the current program scope can be accessed.

## Variable Names

Variable names are 1 to 255 characters.

Assembler variable names are translated to upper case as part of command processing.

## Simple Variables

Simple variables are defined by name only.

## Aggregate Variables

Structures are examples of aggregate variables, where a number of variables are associated together in a hierarchical manner.

The major component is the term which is used to define the variable which "owns" the aggregate. The variables within the aggregate are variously known as components, fields, and members depending on the source language.

### Dot Qualification

A simple variable can have the same name as a variable which is within a structure. In this case, *dot qualification* is used to distinguish the variables.

```
Dcl
  minor      Char(1), /* Simple variable */

  1 major    Char(3), /* Structure */
  2 minor    Char(1),
  2 minor2   Char(1),
  2 minor3   Char(1);

var minor      <- "MINOR" is an ambiguous name
var .minor     <- displays simple variable "MINOR"
var .major     <- displays structure major component "MAJOR"
var major.minor <- displays structure component "MINOR"
```

When a structure is more than 2 levels deep, IDF lets you omit any of the leading names, as long as the name is not ambiguous. If multiple variables within the same structure have the same name, and dot qualification levels are skipped, IDF selects the component which is reached in the fewest number of skipped levels.

### Based Variables

You can specify based variables by name only, in which case the *implicit* variable basing is used if available. This is:

- The variable basing which was defined when the variable was declared. For some variables, such as parameters, this information is determined during the extraction process (by ASMLANGX).
- The variable basing as redefined by an active assembler USING statement.

Alternatively, you can specify an *explicit* locating expression, making use of the -> locator operator.

There are limitations in the processing of some Assembler USING statements by ASMALNGX, which in turn limits ASMIDF. These USING statements are:

- Dependent USINGs (labeled and unlabeled).
- USINGs coded with an end value.
- USINGs that do not cover the start of an area:

```
USING MYAREA+4096,R8 - There is no USING MYAREA,R7
```

### Array Indexing

Information regarding the upper and lower bounds of each array dimension are defined within the IDF Language extract file.

Array indexes are specified from most-significant to least-significant in a left to right direction. Array elements are mapped within the array in *row major* order.

If too many array indexes are specified, a warning message is issued and the extra indexes are ignored.

If insufficient array indexes are specified, a warning message is issued and the remaining indexes are set to the low bound of the corresponding array dimension.

The indexing expression can be:

- PL/I-like-style, where the index values are enclosed within parentheses
- C-style, where the index values are enclosed within either square brackets ("[" and "]"), or the equivalent triglyphs ("??(" and "??)")

The style used is only significant if a substring specification follows the array index specification.

Variables and built-in function results can specify array index specifications.

Array index values must normally be within the bounds defined by the variable declaration. Suppress this check with the CHECK BOUNDS OFF command.

## Substrings

For Character String and Bit String variables, you can specify that only a portion of the string (known hereafter as a substring) is processed by a command.

There are three basic forms of substring specifications:

1. single element
  - varname(element-index)
2. from-to notation
  - varname(from-element-index:to-element-index)
3. length notation
  - varname(from-element-index::element count)

The definition of the first element of a string varies from language to language. IDF lets you specify the format to be used:

### PL/I-like-style

- array index or substring expression is enclosed within parenthesis
- first element in the string is element **1**

### C-style

- array index or substring expression is enclosed within either square brackets ("[" and "]"), or the equivalent triglyphs ("??(" and "??)")
- first element in the string is element **0**

Variables and built-in function results can be used to specify substring specifications.

Substring expressions follow any array index specifications, with a delimiting comma.

Substring ranges must normally be within the limits defined by the variable declaration. Suppress this check with the CHECK SUBSTRING OFF command.

### Examples

Some examples of valid variable expressions are:

```
var stuff
str addr(x'20000')->struct
var addr(12(R2))->ptr->stuff(2)
var ptr->ptr2->stuff
var ptr(3)->ptr->stuff
arr stuff(-5)
arr stuff(1:10)
arr stuff(1::25)
var var1;var2
var var1 ;ptr->stuff
var stuff(1:10) ; stuff(30:40)
var chrarray(15,1:10);chrarray(15,1::10)
var chrarray[15,0:9];chrarray[15,0::10]
```

---

### Displaying Variable Names

The NAMES command provides a list of the variables that are eligible for display. This list is potentially quite large, so you can provide name patterns. Each name pattern acts as a filter; only names that match at least one name pattern are displayed.

For more information about NAMES, see “NAMES” on page 151.

---

### Displaying CALLERS

Calling hierarchy information display is supported for all programs which use the standard OS/VS "Type-1" convention for Save Area area register usage and chaining.

For more information about displaying the calling hierarchy information for one or more generations in the program caller hierarchy, see “CALLERS” on page 98.

---

## Chapter 10. Commands and Operating Procedures

This Chapter describes each IDF command, with the exception of EXTRACT which is used only in macros. The EXTRACT command is described in Chapter 15, “EXTRACT Command” on page 222.

IDF commands perform the same functions regardless of whether they are invoked through a PF key, the command line (when a PF key set to COMMAND is pressed), or a macro.

If you have not read “Arguments and Cursor Positioning” on page 75, please do so before you continue. Many of the following command descriptions assume you understand how IDF obtains an address from the cursor position.

The documentation of each command describes a way in which the command will work. The IDF command processor is powerful and flexible, and it is possible that there are alternative undocumented variations to these commands that will also work.

---

### IDF Commands Cross-reference

---

#### Breakpoint Commands

Command	Page
ADSTOP	88
ADSTOPS	89
BREAK	95
DBREAK	104
REGSTOPS	167
SET ADSTOP	173
SET BREAK	173
SET REGSTOP	179
TRIGGER LOAD	192
UNTIL	194
WATCH	197

---

#### Program Information Commands

BASE	93
CHECK	100
EPOFFSET	110
LOAD	134
LOCATION	137
MODULE	141
MODULE (type)	141
MODULE BASE	142
MODULE SIZE	143

PROGCHK	161
PROGCK	162
PSWSTEAL	162
QUALIFY	164
SELFNUCX	172
SET SIZE	179
STOKEY	186
STOREMAP	187
VERSION	196
XEDEXIT	200

---

#### Program Running Commands

GOTO	117
MACRO	138
MRUN	146
MSTEP	150
PAUSE	157
PER	157
PSW	162
RUN	169
RUNEXIT	169
SET PSW	178
SKIPSTEP	183
STEP	185

## IDF Commands

STMTSTEP	185
SUBSET	189
SVC	189
SYMBOL	190
TASKS	191
VALUE	194
WHERE	199
<b>Program Exit Commands</b>	
ABEND	88
QQUIT	164
QUIT	165
RCQUIT	165
<b>Register Modification Commands</b>	
FPC	116
FPR	117
GPR	118
R0-R15	170
<b>Meta Control Commands</b>	
APROGMSG	90
AUDIT	92
DROP GLOBAL	108
DROP MODULE	108
DROP SYMBOLS	109
EXITEXEC	110
GLOBALS	117
GPACK	118
GSTATUS	118
HISTORY	120
ICOUNT	121
KWDSYN	121
LIBE	133
MODE	141
MPACK	146
MSTATUS	150
PRESERVE	159
RESTORE	167
SALIMIT	170
SAREGS	171
SAVE	171

SET EXITEXEC	174
SET GLOBAL STEM	175
SET GLOBAL TEXT	176
SET ICOUNT	176
SET OPTION	177
<b>Terminal Control Commands</b>	
ALARM	89
COLORS	101
COMMAND	102
CURSOR	104
LASTMSG	132
MSG	148
MSGID	148
MSGMODE	149
PFK	158
PFKDISP	158
QUIET	164
QUIETLY	164
REFRESH	166
RETRIEVE	167
SET COMMAND	174
SWAP	189
<b>Window Open and Close Commands</b>	
AFPR	89
CALLERS	98
CLOSE	101
DISASM	107
DUMP	109
LANGUAGE +	121
MAP	139
OPEN	154
OPTIONS	155
OREGS	156
PARMS	156
REGS	167
STATUS	184
<b>Window Manipulation Commands</b>	
BACK	93
DOWN	108
DUMPMODE	110

FIND	111
FOLLOW	114
LEFT	132
LOCATE	137
MAXIMIZE	140
MINIMIZE	140
MOVE	144
NEXT	152
OFFSET	153
ORDER	155
PLOCATES	159
PREVIOUS	160
RIGHT	168
SEARCH	171
SET OFFSET	176
SIZE	181
TITLE	191
UP	194

**Source Level Set and Query Commands**

BINARY	93
BIT	94
BRIEF	97
CHARACTER	99
COMPACT	102
DETAIL	106
EXLIMIT	111
FIXED	113
FLOAT	114
FMT	114
FORMAT	115
LANGUAGE COLOR	122
LANGUAGE COMMENTS	123
LANGUAGE DECLARES	124
LANGUAGE MACROS	127
LANGUAGE OPTIONS	128
LANGUAGE STATUS	129
LANGUAGE STEM	130
LANGUAGE VERSION	130
LANGUAGE XPATH	130
PACKED	156

SPACE	184
VSEP	197
ZONED	200

**Source Level Display Commands**

ARRAY	91
BOTTOM	94
FIRST	113
HIDE	119
LANGUAGE DEBUG	123
LANGUAGE DROP	124
LANGUAGE LOAD	125
LANGUAGE SCROLL	128
LAST	131
MAJOR	139
NAMES	151
SHOW	179
STRUCTURE	187
TOP	192
TYPE	193
UNION	194
VARIABLE	195

**Logging Commands**

RLOG	168
VCHANGE	196
VS	197

**Access and Control Register Commands**

ALET	90
AREGS	91
CREGS	103
LOCATION ALET	138
SET AREG	173

## ABEND (CMS and TSO)

Performs the usual IDF cleanup, then issues an OS ABEND. Use this command *only* for the intentional triggering of a working ABEND intercept routine.

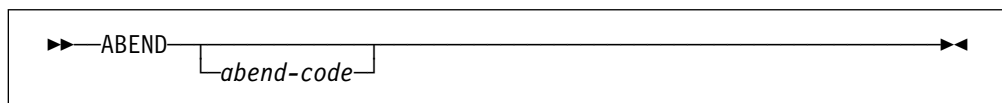

### *abend-code*

A valid IDF expression denoting the ABEND code.

If no argument is supplied, the command line is checked for an expression and if a valid expression is found its value is used as the ABEND code. If no argument is provided and the command line is empty, the current contents of the target program's R15 are used as the ABEND code.

## ADSTOP (CMS only)

Sets one end of a Storage Alteration Stop (ADSTOP) range.

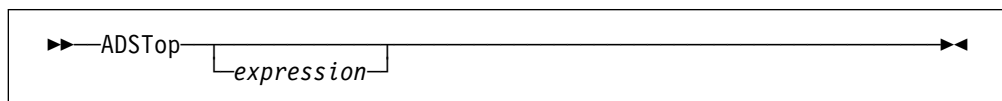

### *expression*

The storage location. If not supplied, the address is determined from the cursor position, if possible.

If no expression is provided on the command line, and it is not possible to determine an address from the cursor position (for example when the cursor is on the command line and the command line is empty), this command is processed as an ADSTOPS command (see “ADSTOPS (CMS only)” on page 89).

All locations between (and including) the start address of the range and the end address of the range are monitored for storage alteration. Up to four separate storage areas can be monitored simultaneously. You are notified when a monitored location is modified.

Since the ADSTOP command sets one end of a range, you must issue it twice to define the range.

Storage locations can only be monitored for alteration when PER is enabled. Entering the ADSTOP command when PER is disabled produces an error message.

Because of the way the PER hardware works, IDF partially disassembles any instruction that changes PER storage, to determine the storage address modified. From this it determines whether the storage address falls in one of the defined ranges. The partial disassembly is valid for most of the common instructions. Some instructions do not resolve to the correct address. If you miss storage modification stops, you may need to set the 1ADSTOP option (see “SET OPTION” on page 177). This option treats the four ranges you have specified as a single

storage area, from the lowest address in all of the ranges to the highest. When the 1ADSTOP option is set, partial disassembly is not needed to determine the address of modified data.

See also “SET ADSTOP (CMS only)” on page 173.

### Return codes

- 0 Operation successful
- 5 Syntax or other error in expression
- 6 PER is disabled, or an ADSTOP is already set at that location

## ADSTOPS (CMS only)

Toggles the display of the AdStops window.

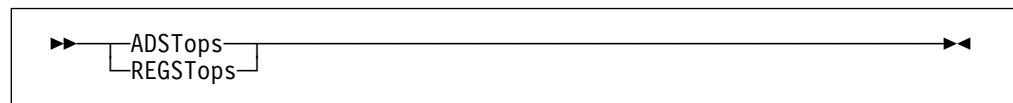

The AdStops window is opened if it is not already open. If the AdStops window is already open, it is closed.

See also “ADSTOP (CMS only)” on page 88, “SET ADSTOP (CMS only)” on page 173, and “SET REGSTOP (CMS only)” on page 179.

### Return codes

- 0 Operation successful
- 6 PER is disabled

## AFPR

Toggles the display of the Additional Floating-Point Registers window.

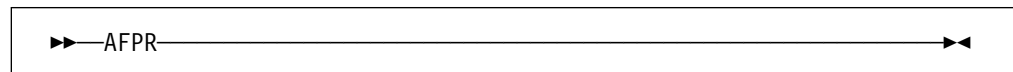

The Additional Floating-Point Registers window is opened if it is not already open. If the Additional Floating-Point Registers window is already open, it is closed.

### Return codes

- 0 Operation successful

## ALARM

Controls the terminal alarm.

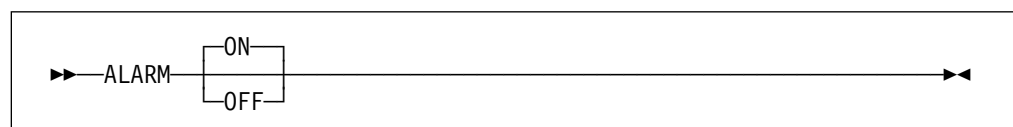

## ALET

### ON

Ring the terminal alarm.

### OFF

Reset the terminal alarm.

### Examples

```
SET ALARM
SET ALARM ON
SET ALARM OFF
```

---

## ALET

Specifies the ALET used to qualify the dataspace to be displayed in a Dump window.

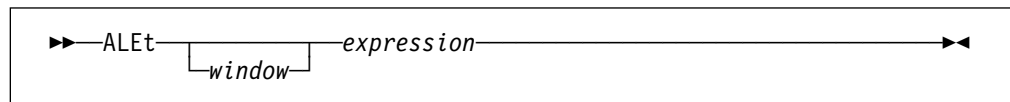

### *window*

The window whose ALET is to be set. Select by a Window Specification or by placing the cursor in the window. If omitted and the cursor is not in a Dump window, sets the ALET for the first Dump window.

### *expression*

If an access register is used in the expression, the ALET in the referenced access register is used instead of the value of the expression.

You must be in an ESA environment for this command to work.

### Examples

```
SET ALET =3 X'00010003'
SET ALET =2 0(AR4)
```

---

## APROGMSG (CMS only)

Enables and disables the trapping of asynchronous program-checks that happen while IDF displays the user interface.

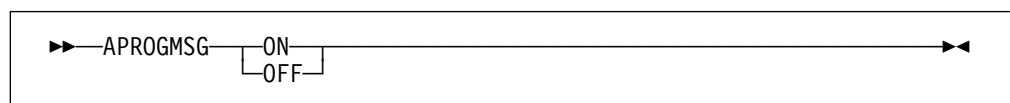

### ON

Enable trapping of asynchronous program-checks.

### OFF

Disable trapping of asynchronous program-checks.

## AREGS

Rotates the register display between the General Purpose and the Access Registers. Valid only in an ESA environment.

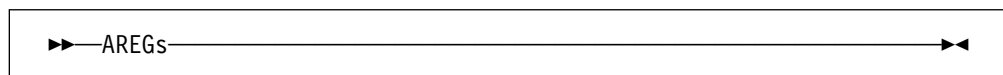

When issued, opens the Current Registers window if it is not already open.

### Return codes

- 0 Register display was toggled
- 7 Not valid in this environment.

## ARRAY

Displays the contents of one or more variables which are array elements.

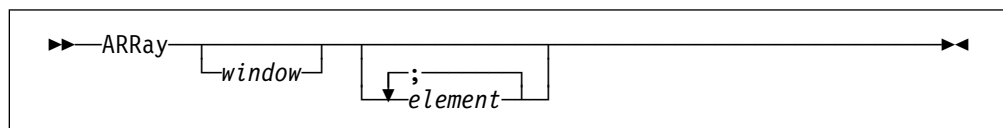

### *window*

The LSM Information window used to display the array element contents information. Select it by a Window Specification, or by placing the cursor in the window.

If supplied, the window must be an LSM Information window. If omitted, the first LSM Information window is used. If no LSM Information window is open, one is opened.

### *element*

A variable name.

Simple variables are defined by name only. You can define based variables by name only, in which case the declared basing is used by IDF, or you can specify an explicit locating expression.

See “Variable Expressions” on page 81 for a complete description of the syntax of the expressions which may be used for ARRAY variable name arguments.

The array element display persists until:

- An ARRAY command without arguments is issued
- The window is closed with a CLOSE command.
- Another IDF Language command such as VARIABLE, STRUCTURE, TYPE, CALLERS, PLOCATES, LANGUAGE STATUS, or MAP is issued, which directs IDF to update the LSM Information window with new information
- The target program completes execution
- Target program execution progresses beyond the variable's defined scope

## AUDIT

If the contents of the array element change while the program is running to a breakpoint, the changed data is shown on the screen when the breakpoint is reached.

You can change the displayed data by overtyping it.

In EBCDIC display mode, character data equal to X'FF' or below X'40' is displayed as a period character.

In ASCII display mode, character data which does not correspond to a displayable EBCDIC character is displayed as a period character.

If a based variable was respecified, the current active USINGs will be used to locate the variable.

The display of the contents of the variables may be incorrect if the PSW indicates that execution is in the middle of a statement. This is because the variable may be in a transitional state, not having yet achieved its new value. Variable contents are only certain at the start and end of a statement.

### Examples

```
array stuff(15)
array addr(x'20000')->stuff(20)
array addr(12(R2))->ptr->stuff(2)
array ptr->ptr2->stuff
array ptr(3)->ptr->stuff
array array1(10);array2(-5)
array chrarray(15,1:10);chrarray(15,1::10)
array chrarray[15,0:9];chrarray[15,0::10]
```

---

## AUDIT

Enables and disables display of variable basing audit information.

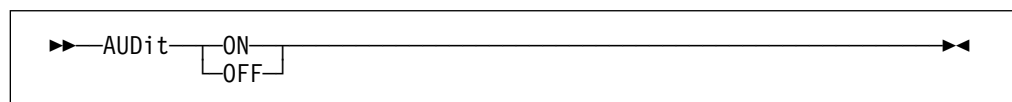

### ON

Enables the display of variable basing audit information.

### OFF

Disables the display of variable basing audit information. This is the initial setting.

When a based variable is displayed, IDF can optionally provide an audit trail to show you the intermediate results of the variable location calculation.

### Return codes

- 0 Operation successful
- 1 Missing keyword
- 2 Keyword truncated
- 3 Keyword unknown

---

**BACK**

Makes a Dump window display the storage it displayed on the previous DUMP command for that window.

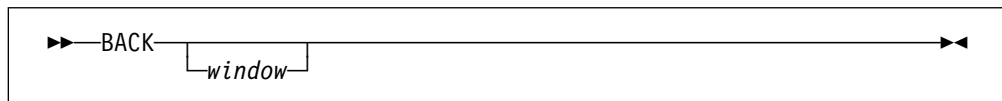
*window*

A Dump window. Select by a Window Specification or by placing the cursor in the window. If a Window Specification is not present and the cursor is not in a Dump window, uses the first Dump window.

IDF maintains the addresses used on the last ten DUMP commands for each open Dump window in a circular buffer.

**Return codes**

- 0 Operation successful
- 6 No Dump windows are open at this time.

---

**BASE**

Specifies the base address of the target program specified when IDF was invoked.

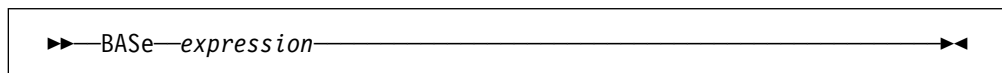
*expression*

An expression that resolves to an address value.

Use the MODULE BASE command (see “MODULE BASE” on page 142) to set the base address of other programs defined to IDF.

May be used when debugging a self-loading nucleus extension to follow the code to its new location.

**Examples**

```
SET BASE X'21000'
```

---

**BINARY**

The BINARY command is a synonym of the FIXED command. For details see “FIXED” on page 113.

## BIT

---

## BIT

Sets or queries the format used to display the data for bit variables.

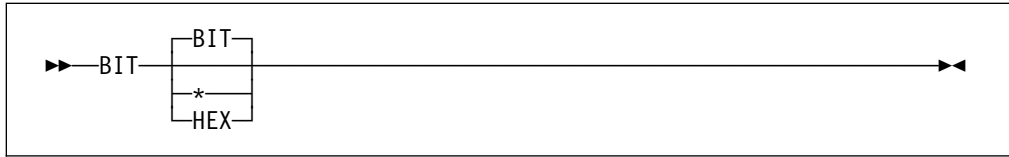

### BIT

Bit variables are displayed as a string of 0 and 1 characters.

- \* Bit variables are displayed in the default format (BIT).

### HEX

Bit variables are displayed in hexadecimal. This mode is especially useful for displaying long bit strings.

If the length of the bit string is not a multiple of 4 bits, the last hexadecimal character represents less than 4 bits. Since bit strings are left justified, the extraneous trailing bits are ignored if you overtype this nibble with a new value with 1 bits in any of these positions. A warning message is shown, and the new digit is displayed with the corrected hexadecimal value.

If the display format is not specified, a message shows the current display format for bit variables.

### Return codes

- 0 Operation successful
- 2 Keyword truncated
- 5 Not valid bit variable display format

---

## BOTTOM

Displays source code starting at the highest available address within the current code section.

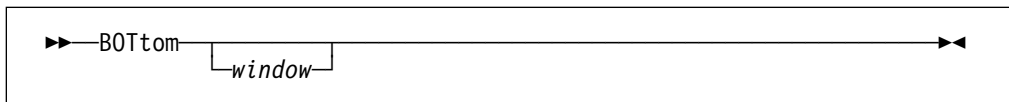

### *window*

A Disassembly window. Select by a Window Specification or by placing the cursor in the window.

If omitted, and the cursor is not in a Disassembly window, uses the first Disassembly window.

## Return codes

- 0 Operation successful
- 6 No code section definition corresponds to the current address.

---

## BREAK

Sets an instruction breakpoint, or toggles the Break window display.

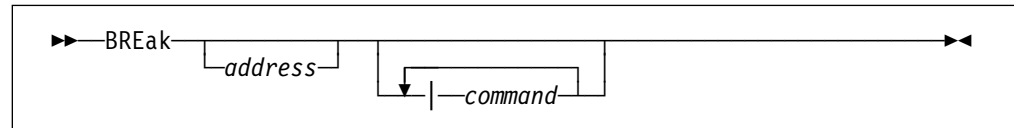

### *address*

An address. If an expression, the expression is used to provide the address.

If omitted, the address is determined from the cursor position. If it is not possible to determine an address from the cursor position (for example when the cursor is on the command line and the command line is empty), the Break window is opened if it is not already open, or closed if it is open.

### *command*

A command to be executed immediately after the breakpoint is taken.

To set a deferred or sticky breakpoint, use the DBREAK command. See “DBREAK” on page 104 for details.

If an address is supplied, either as an expression on the command line or by means of cursor position, a breakpoint is set at that address. If a breakpoint or a watchpoint is already set at the specified address, it is cleared. The BREAK command is a toggle that turns a breakpoint on or off. (The OLDBREAK option is available if the toggle style of operation is not desired. If OLDBREAK is set and the BREAK command is used against an address where a breakpoint is already set, an error message is issued.)

The breakpoint is taken (that is, execution is interrupted and the operator notified) just prior to the execution of the indicated instruction. A maximum of 64 breakpoints may be active at one time. Breakpoints remain in effect until they are explicitly cleared (through the Break window).

You can associate a list of commands with the breakpoint. These commands are executed when the breakpoint is taken, before control is returned to you. The commands are specified at the end of the BREAK command, separated from the address and each other by vertical bars (|). If a command receives a non-zero return code, the remaining commands in the list are not executed.

**CMS** ➤ IDF provides two types of instruction breakpoint, PER and non-PER. If PER is enabled (with the Break window or SET PER command) then all breakpoints are PER breakpoints. Likewise, if PER is disabled, all breakpoints are non-PER breakpoints.

- PER breakpoints are implemented by means of PER Instruction Fetch and Branch events, and are only possible so long as the processor can be kept in Extended Control mode. In some cases, for example when an SVC is issued in a read-only DCSS, Extended Control mode is dropped by CMS.

## BREAK

- Non-PER breakpoints are implemented by temporarily inserting an invalid opcode at the indicated location.

For more information about the distinction between the two available breakpoint types, see “PER Versus non-PER Mode” on page 51 . 

 IDF provides two types of instruction breakpoint, SVC 97 and non-SVC 97.

- SVC 97 breakpoints are implemented by temporarily inserting an SVC 97 instruction at the indicated location.
- Non-SVC 97 breakpoints are implemented by temporarily inserting an invalid opcode at the indicated location.

For more information about the distinction between the two available breakpoint types, see “Breakpoint Method Selection” on page 35 . 

 IDF provides one type of breakpoint.

- A breakpoint is implemented by temporarily inserting an invalid opcode at the indicated location. 

If a WATCH command with a condition is issued for an address at which there is a breakpoint, that breakpoint is converted into a watchpoint. If commands were specified with the original breakpoint, they are associated with the watchpoint unless commands were specified with the WATCH command.

If a breakpoint is placed within the execution path of the subroutine to be skipped, execution stops at that breakpoint.

IDF verifies that there is a valid instruction at the breakpoint address, and rejects the BREAK command (with a message) if not. This test is not infallible. Certain combinations of DATA can appear as valid instructions. For example X'1E14' might be data or it might be an ALR R1,R4. IDF lets you install a break here.

For non-PER and non-SVC 97 breakpoints, IDF uses an invalid instruction of the format x'01xx', to cause a program-check (operation exception), which gives IDF control to handle the breakpoint logic. At the time of handling the breakpoint, IDF reinstalls the original instruction bytes for execution. But if you manage to install a non-PER breakpoint (that is, x'01xx') on top of program DATA (which looks like an instruction), then IDF never gains control to remove its x'01xx' from your program's DATA. So IDF corrupts valid data, potentially leading to bizarre program behavior. Take care to install breakpoints only on valid target program instructions.

| IDF establishes breakpoints by modifying target instructions to invalid opcodes (or  
| SVC 97 instructions if SVC97 under TSO is in effect). The DISASM window only  
| displays the original instruction. If a breakpoint is established on an instruction  
| which is the target of an EXecute instruction, then the EX instruction will fail.

 As part of the test for a valid instruction, IDF backs up 2 bytes from the breakpoint instruction (assuming that the instruction appears valid so far), and checks for:

On **CMS** SVC 201 (x'0AC9'), SVC 202 (x'0ACA'), and SVC 203 (x'0ACB') respectively.

**On VSE SVC 34 (x'0A22')**

Each of these SVCs may be followed by DATA bytes. If IDF finds any of these codes preceding the breakpoint address, IDF assumes that the breakpoint instruction is in fact DATA for the SVC, and prevents the breakpoint installation.

This check cannot be 100% certain that the x'0Axx' preceding the breakpoint address is in fact an SVC. It is possible that it is also DATA, or perhaps the last 2 bytes of a 4- or 6-byte instruction. However the risk of either of these is small, and since the result of allowing a breakpoint to be installed on top of SVC 203 data (for example) is catastrophic, being over-zealous in its checking is worthwhile.

If IDF rejects (due to the above SVC test) an attempted breakpoint installation on what you know for certain is a valid instruction you should be able to successfully install the break on the *next* instruction. ◀ CMS, VSE

See also "SET BREAK" on page 173.

**Return codes**

- 0 Operation successful
- 5 Syntax or other error in expression
- 6 Location does not contain a valid instruction, location is read only and PER is unavailable, or a breakpoint already set at that location and the OLDBREAK option is on.

**BRIEF**

Controls the display of declaration information when a variable is displayed.

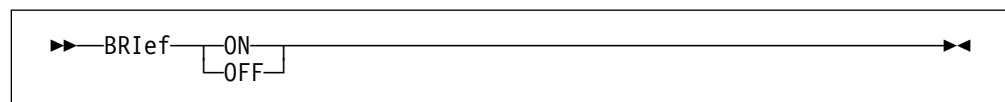
**ON**

Disables the display of declaration information.

**OFF**

Enables the display of declaration information. This is the initial setting.

The COMPACT option is initially ON, which also suppresses the declaration information. To display the declaration information, both the COMPACT and the BRIEF options must be OFF.

**Return codes**

- 0 Operation successful
- 1 Missing keyword
- 2 Keyword truncated
- 3 Keyword unknown

## CALLERS

Displays information for each generation in the program caller hierarchy.

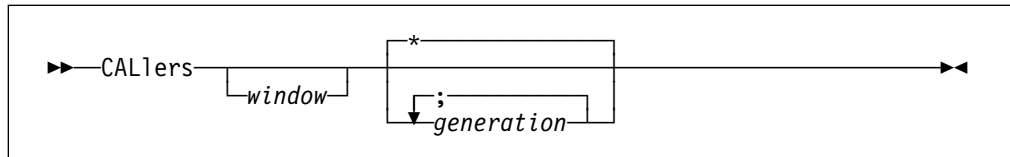

### *window*

A LSM Information window. Select by a Window Specification, or by placing the cursor in the window.

If supplied, the window must be an LSM Information window. If omitted, and the cursor is not in an LSM Information window, uses the first LSM Information window. If no LSM Information window is open, one is opened.

- \* Information is shown for all caller generations, beginning with the current location and followed by all previous generations along the save area chain until either:
  - the save area back link is zero
  - the save area back link contains an invalid address
  - the generation specified by the SALIMIT command is reached

### *generation*

A program caller generation.

The program caller generations numbering convention is:

- 0** current program
- 1** parent (caller)
- 2** grand parent (caller of caller), and so on

When supplied, information is displayed for only the nominated caller generations.

The information displayed for each generation in the program caller hierarchy includes:

- Current execution location, as:
  - Memory location, in IDF symbolic format  
(module.CSECT)Stmt#nnnnn+offset
  - Logical location  
program-block-name+offset

This location is only provided when extract data was loaded, for the program. Extra information may also be used from data areas in the program's storage.

- Save Area Header
- Save Area register values, if applicable

Use the SAREGS command to enable and disable the display of the Save Area header and registers in the CALLERS display. The Save Area registers are formatted according to the IDF ROWSTYLE option setting.

Use the SALIMIT command to control the maximum depth of the CALLERS display. This is intended to prevent problems when the program call chain is damaged, or is of unexpected depth (due to runaway recursion).

The calling hierarchy information display persists until:

- A CALLERS command without arguments is issued when the current Call Hierarchy command had no arguments.
- The window is closed with a CLOSE command.
- Another IDF Language command such as VARIABLE, STRUCTURE, ARRAY, TYPE, PLOCATES, LANGUAGE STATUS, or MAP is issued, which directs IDF to update the LSM Information window with new information.
- The target program completes execution.

**Examples**

```
CALLERS
CALLERS 0;99
```

**CHARACTER**

Sets or queries the format used to display the data for character variables.

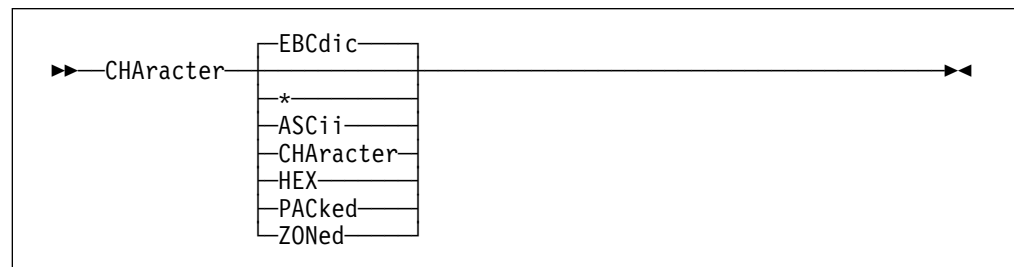

**EBCDIC**

Character variables are EBCDIC, with unprintable characters (X'00' to X'3F', X'FF') displayed as . (periods).

- \* Character variables are displayed in the default format (EBCDIC).

**ASCII**

Character variables are ASCII, with unprintable characters displayed as . (periods).

**CHARACTER**

Character variables are displayed as EBCDIC or ASCII, tracking the value of the ASCII setting selected for the DUMP command. Unprintable characters are displayed as . (periods).

**HEX**

Character variables are displayed in hexadecimal. This mode is especially useful for buffers which are declared as CHAR and which contain non-character information.

**PACKED**

Character variables of less than 24 bytes are displayed in Packed Decimal format. Variables exceeding this length are displayed in hexadecimal. This

## CHECK

mode is especially useful for examining data in a language without native Packed Decimal variables.

### ZONED

Character variables of less than 48 bytes are displayed in Zoned Decimal format. Variables exceeding this length are displayed in EBCDIC. This mode is especially useful for examining data in a language without native Zoned Decimal variables.

If the display format setting is not specified, the current display format for character variables is shown in a message.

### Return codes

- 0 Operation successful
- 2 Keyword truncated
- 5 Not valid character variable display format

---

## CHECK

Controls the checking of selective input values when variable information is displayed or altered by overtyping.

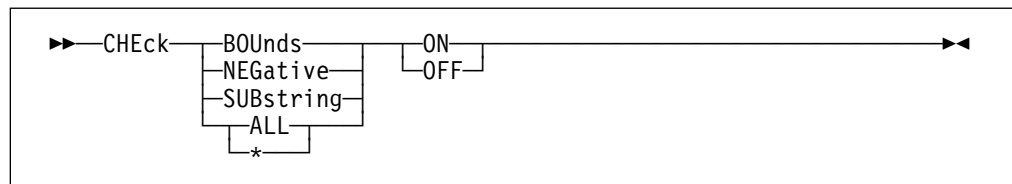

### BOUNDS

Controls array index specification processing.

#### ON

Array indices must be inside the declared range.

#### OFF

Array indices outside the declared range may be specified, allowing you to follow errant program results.

This option also affects scrolling behavior of the ARRAY command.

### NEGATIVE

Determines whether negative values can be assigned to Unsigned Fixed variables.

#### ON

An error message is issued and the variable is not updated.

#### OFF

A warning message is issued and the variable is updated. Attempts are made to update both the storage and register portions of shadowed variables, but expressions derived from variables are *not* reevaluated.

### SUBSTRING

Controls substring index specification processing for character string and bit string variables.

**ON**

Substring indices must be inside the declared range.

**OFF**

Substring indices outside the declared range (including negative values) may be specified, allowing you to follow errant program results.

**ALL | \***

Applies ON or OFF processing to BOUNDS, NEGATIVE and SUBSTRING.

**Return codes**

- 0 Operation successful
- 1 Missing keyword
- 2 Keyword truncated
- 3 Keyword unknown

**CLOSE**

Closes a window.

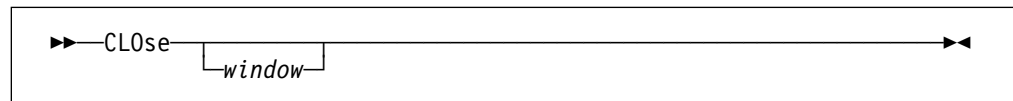
*window*

A window. Select by a Window Specification or by placing the cursor in the window.

**Return codes**

- 0 Operation successful
- 1 No window selected.

**COLORS**

Sets the colors used to display IDF display elements.

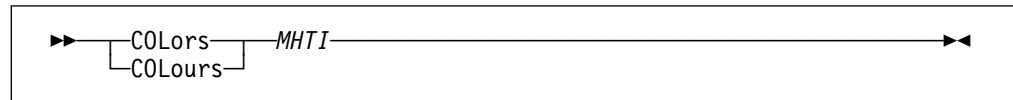
*MHTI*

A four-letter color specification. Each position indicates the color for a screen element. The positions are:

- 1 Messages
- 2 Headings
- 3 Text
- 4 Input areas

Valid letters are:

- B** Blue
- G** Green

## COMMAND

**P** Pink  
**R** Red  
**T** Turquoise  
**Y** Yellow  
**W** White

### Examples

SET COLORS RYGB

This example sets the following color scheme:

**Messages** Red  
**Headings** Yellow  
**Text** Green  
**Input** Blue

---

## COMMAND

Performs the IDF command specified on the command line.

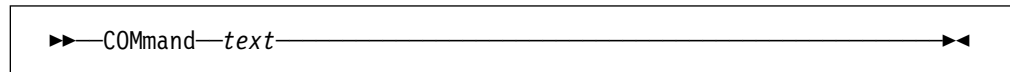

### *IDF-command*

The IDF command to be executed.

### *arguments*

Arguments to be passed to the command. The particular arguments depend on the command that is supplied.

The command line is examined for the name of the IDF command. If the command is not known to IDF, the IMPMACRO option is checked. If this indicates that implied macro processing is desired, the indicated macro is used as the command.

The command name is then temporarily removed from the command line, so that any arguments which are present are available to the specified command. The command is then executed as if you have pressed a PF key.

If the command line is empty and no input fields in the remainder of the screen are changed, the only function performed is to move the cursor to the command line.

### Return codes

The return code when COMMAND is issued by a macro is the propagated return code from the IDF command.

---

## COMPACT

Minimizes the number of lines used for variable display.

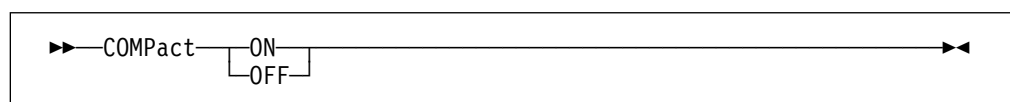

**ON**

As with BRIEF ON, disables the display of declaration information. This is the initial setting.

To further reduce the number of display lines, if the length of the variable value permits the variable name and contents are shown on the same display line. If sufficient space exists, the variable location information is also shown in this case.

**OFF**

As with BRIEF OFF, enables the display of declaration information.

When you display a variable, IDF normally uses multiple lines of the display to show all the variable information. When variables with short names and short formatted values are displayed, much of these display lines contain blanks. Use the COMPACT display mode to minimize the number of lines used for variable display.

As with the BRIEF display mode, the optional variable declaration information is suppressed.

To maximize the number of variables that can be displayed, you can use the SPACE OFF command to eliminate the blank line optionally generated between variables.

The COMPACT option is initially ON, which also suppresses the declaration information. To display declaration information, the COMPACT and BRIEF options must both be OFF.

**Return codes**

- 0 Operation successful
- 1 Missing keyword
- 2 Keyword truncated
- 3 Keyword unknown

---

**CREGS (CMS only)**

Toggles the register displayed between the General Purpose and Control Registers. Valid only while PER exploitation is disabled (option PER is N).

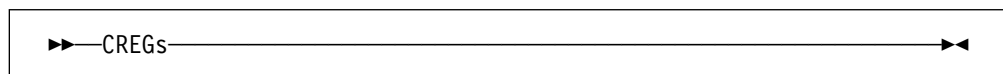

The CREGS command opens the Current Registers window if it is not already open.

**Return codes**

- 0 Register display was toggled
- 6 Unable to comply due to PER setting

## CURSOR

Provides IDF macros with some control over cursor positioning.

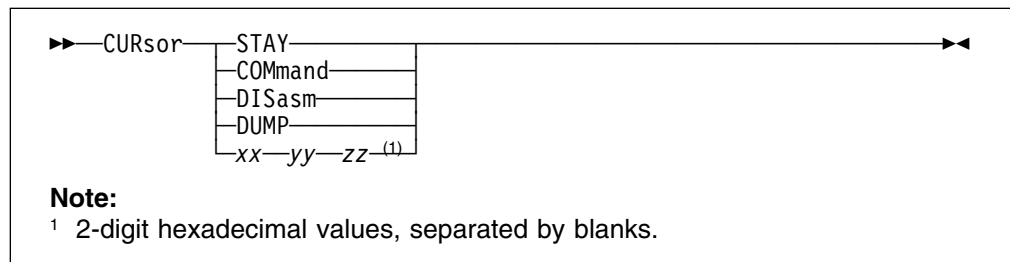

### STAY

Leaves the cursor at the position it had when the PF key was pressed.

### COMMAND

Positions the cursor at the start of the command line.

### DISASM

Places the cursor in the first input field of the Disassembly window.

### DUMP

Places the cursor in the first input field of the Dump window.

### xx yy zz

Positions the cursor at an absolute position on the screen.

These three values are blank separated, 2-digit *hexadecimal* numbers representing:

- The window containing the cursor
- The row within the window of the cursor
- The column within the window of the cursor

### Examples

```
SET CURSOR STAY
SET CURSOR COMMAND
SET CURSOR DISASM
SET CURSOR DUMP
'SET CURSOR' varname
```

## DBREAK

Sets or clears a deferred instruction breakpoint.

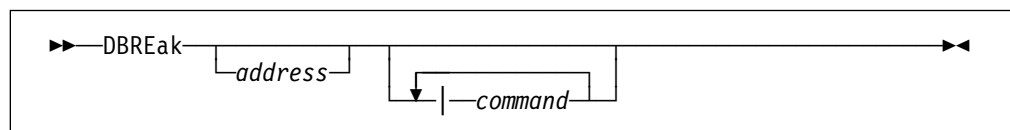

### address

An address. If an expression, the expression is used to provide the address.

If omitted, the address is determined from the cursor position. If it is not possible to determine an address from the cursor position (for example when

the cursor is on the command line and the command line is empty), the Break window is opened if it is not already open, or closed if it is open.

*command*

A command to be executed.

This function is a variation of the BREAK function (see “BREAK” on page 95). Breakpoints established with this command are placed in a special IDF table.

If an address is supplied, either as an expression on the command line or by means of cursor position, a deferred breakpoint is set at that address. If a breakpoint or a watchpoint is already set at the specified address, it is cleared. The DBREAK command acts as a toggle to turn a breakpoint on or off. (The OLDBREAK option is available to disable the toggle style of operation. If OLDBREAK is set and the DBREAK command is used against an address where a breakpoint is already set, an error message is issued.)

If the module containing the deferred breakpoint is *not* in storage (or defined to IDF):

- IDF monitors program loading
- When IDF detects the module is loaded, (or the TRIGGER LOAD command is issued) a standard instruction breakpoint is established at the location specified within the module.
- The deferred breakpoint remains active:
  - if the module is subsequently dropped from IDF’s module list (and possibly removed from storage), the standard instruction breakpoint is removed automatically.
  - if the module is once again loaded into storage, the deferred breakpoint is again triggered, and a new standard instruction breakpoint established.

Thus IDF deferred breakpoints may be termed “sticky.”

If the module containing the deferred breakpoint *is* in storage, the initial monitoring of program loading is bypassed.

If any deferred breakpoints are active, they are shown in a special section of the Break window. See “BREAK” on page 95 for details regarding the operation of the Break window.

1. The full syntax for all IDF symbols is:

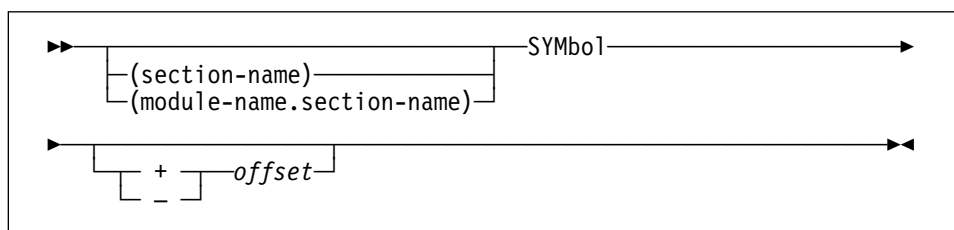

With most other IDF commands, you are working within the qualified module. This is the default module name if *module-name* is omitted from the symbol specification.

## DETAIL

The QUALIFY command makes the module you are about to load the default module. If this is not done, you must be *very careful* to explicitly specify the correct module name in the DBREAK command parameter.

2. Deferred breakpoints are normally for modules not yet in storage. In this case, the expression must specify a symbolic address, since the base address of a module is not known until after it is loaded by another program or command.
3. Each time a new module is encountered, the module name is checked. If it matches the name of one of the desired modules, IDF then attempts to load the symbol table (from the Load Module on TSO, from the MAP file on CMS, from the librarian MAP member in VSE). If this fails, IDF ignores the module.
4. If no section or symbol is specified, the default is to establish the breakpoint at the entry point of the module.

For example, to insert a deferred breakpoint at the entry point of the module MOD1, the command is:

```
DBREAK (MOD1.)
```

5. DBREAK supports an extension to the standard IDF symbol syntax. If \* is specified as the module name, the deferred breakpoint is triggered whenever a new module is loaded.
6. You should use external symbols in a DBREAK address expression. Internal symbols may not be unique within a particular module.
7. While hexadecimal or decimal offsets may be used, this is not encouraged. The definition of specific external symbols for use as deferred breakpoint locations ensures that operation are not affected as section sizes (and hence offsets) change over the course of program development.

### Return codes

- 0 Operation successful
- 5 Syntax or other error in expression

---

## DETAIL

Controls the display of data for the structure components of intermediate depth. Initially, this data is not shown.

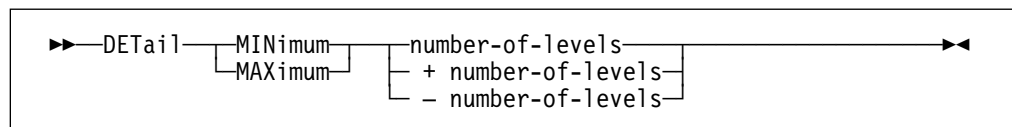

### MAXIMUM

Enables the display of intermediate component data.

### MINIMUM

Disables the display of intermediate component data.

### *number-of-levels*

Integer, indicating number of levels of structure component data to be displayed.

*+ number-of-levels*

Integer, indicating number of extra levels of structure component data to be displayed.

*- number-of-levels*

Integer, indicating the number of fewer levels of structure component data to be displayed.

### Return codes

- 0 Operation successful
- 1 Missing keyword
- 2 Keyword truncated
- 3 Keyword unknown
- 5 Arguments are invalid

---

## DISASM

Displays a disassembly listing.

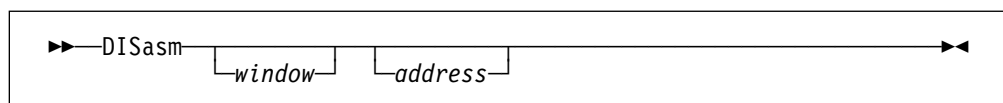

### *window*

A Disassembly window. Select by a Window Specification or by placing the cursor in the window. If omitted and the cursor is not in a Disassembly window, uses the first Disassembly window.

### *address*

An address specifying the storage location at which the disassembly listing begins.

If an address is supplied on the command line, or an address can be determined from the cursor position, a disassembly of the indicated memory area is shown.

If no address is supplied, and an address cannot be determined from the cursor position, a disassembly listing is displayed, beginning at the first instruction which previously appeared on the disassembly display.

If the DISASM function is invoked when no Disassembly windows are open, one is opened.

If the DISASM function is invoked when a Disassembly window is open, but no address is specified, the selected window is closed.

If the DISASM function is invoked when a Disassembly window is open, and an address is specified, the starting address of the disassembly in the selected window is changed.

By positioning the cursor in the first halfword of an instruction and pressing DISASM, you can make that instruction the first one displayed.

If the cursor is positioned in the first halfword of the first instruction displayed, and that instruction is a branch, the effective address of that branch instruction becomes the first instruction disassembled.

## DOWN

### Return codes

- 0 Operation successful
- 5 Syntax or other error in expression
- 6 Specified address exceeds the current virtual memory size

---

## DOWN

The DOWN command is a synonym of the NEXT command. For details, see “NEXT” on page 152.

---

## DROP GLOBAL

Discards the information for stems from Global Storage.

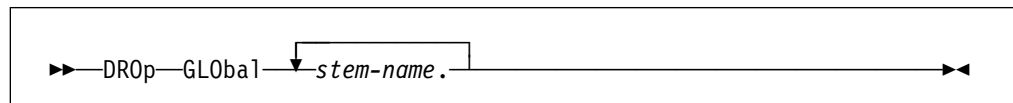

*stem-name*

A Global Storage stem name. Each stem name must have a trailing period.

### Return codes

- 0 Operation successful
- 1 Missing stem name
- 2 Stem name truncated
- 5 Stem name specified is not defined in Global Storage

---

## DROP MODULE

Discards information known about a module and the symbols associated with the module.

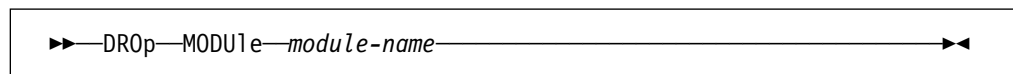

*module-name*

The name of the module for which information is discarded.

The module specified when IDF was invoked cannot be dropped.

### Return codes

- 0 Operation successful
- 1 Missing module name
- 2 Module name truncated
- 5 Module specified not known to IDF

---

## DROP SYMBOLS

Discards symbols known to IDF.

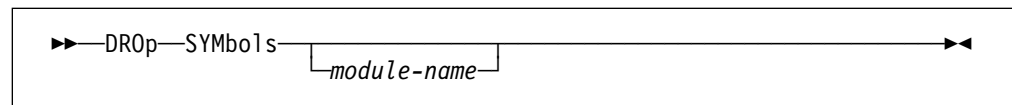

### *module-name*

The name of the module for which symbols are dropped. If omitted, the symbols of the qualified module are dropped.

DROP SYMBOLS and LOAD SYMBOLS (see “LOAD” on page 134) lets you use symbol information from any file, providing the file is recognized by IDF.

---

## DUMP

Displays a storage dump.

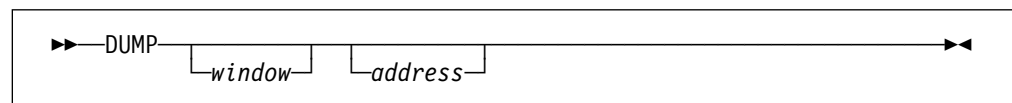

### *window*

A Dump window. Selected by a Window Specification or by placing the cursor in the window. If omitted and the cursor is not in a Dump window, uses the first Dump window.

### *address*

The storage location at which the storage dump begins.

If an address is supplied on the command line, or an address can be determined from the cursor position, a storage dump of the indicated memory area is shown.

If no address is supplied, and an address cannot be determined from the cursor position, a storage dump listing is displayed, beginning at the first instruction which previously appeared on the dump display.

If the DUMP function is invoked when no Dump windows are open, one is opened.

If the DUMP function is invoked when a Dump window is open, but no address is specified, the window is closed.

If the DUMP function is invoked when a Dump window is open, and an address is specified, the starting address of the storage displayed in the window is changed.

IDF provides two DUMP modes, symbolic and unformatted, toggled by the DUMPMODE command.

The symbolic dump shows the names of storage areas along with the contents of each named area. The unformatted dump shows the traditional storage dump.

The storage dump shown by the DUMP command is presented in the current dump format. Toggle the dump format with the DUMPMODE command.

## DUMPMODE

By positioning the cursor in a hexadecimal field displayed on the screen before pressing DUMP, you can make that field the first one displayed.

If the cursor is positioned in the first field displayed, and that field is a fullword, the low-order 24 bits of the contents of that word specify the first location to DUMP. If the AMODE bit is on, the low-order 31 bits are used instead.

Using this feature, it is easy to follow a linked list. Just place the cursor in the fullword that represents the link word, and repeatedly press the DUMP key.

### Return codes

- 0 Operation successful
- 5 Syntax or other error in expression
- 6 Specified address exceeds the current virtual memory size

---

## DUMPMODE

Toggles the DUMP format between symbolic and unformatted.

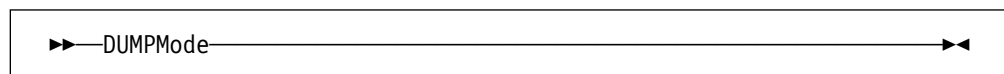

### Return codes

- 0 Operation successful

---

## EPOFFSET

Specifies offset of the primary entry point within a program.

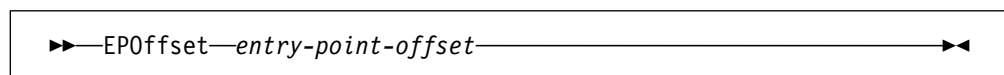

### *entry-point-offset*

An expression which is resolved to the entrypoint offset value. This entrypoint offset is the entrypoint address of the program less the start (base) address of the program.

### Examples

```
SET EPOFFSET X'24'
```

---

## EXITEXEC

Enables or disables (toggles) exit routine processing.

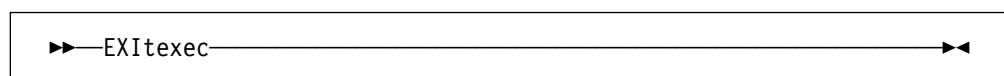

If the current exit routine is present and enabled, it is invoked when execution of the target program would normally be interrupted to notify the operator of an unusual event (such as a breakpoint). The exit routine then determines whether or not to notify the operator of the event.

If exit routine processing is disabled, the exit routine is not invoked and the operator is notified as usual when one of these events occurs.

For more information, see Chapter 13, “The IDF Exit Routine” on page 214.

### Return codes

- 0 Operation successful
- 6 Exit routine not found

## EXLIMIT

Sets the maximum LSM stemmed array index during EXTRACT LANGUAGE commands execution.

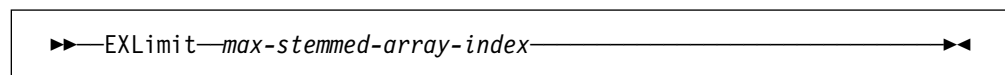

### *max-stemmed-array-index*

Maximum stemmed array index. Integer between 1 and 9999999. The initial value is 20000.

When information is written to the stemmed array, user free storage is consumed. This can present a problem if data is extracted for extremely large variables, or for variables such as unbounded bit or character strings which have no upper limit (aside from the end of machine storage). In these cases, no storage remains for application or IDF operation. EXLIMIT helps prevent this from happening.

### Return codes

- 0 Operation successful
- 1 Missing keyword
- 2 Keyword truncated
- 3 Keyword unknown
- 5 Arguments are invalid

## FIND

Locates a string and displays the section of code where it occurs.

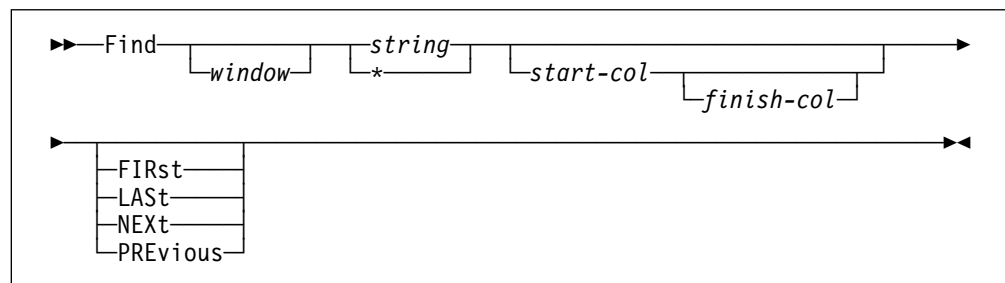

### *window*

A Disassembly window. Select by a Window Specification or by placing the cursor in the window. If omitted, and the cursor is not in a Disassembly window, uses the first Disassembly window.

## FIND

### *string*

The group of characters being searched for, the search string.

Enclose this search text in quotes if it is numeric or contains imbedded blanks. Both "... " and '...' are accepted.

- \* Use the current search string.

### *start-col*

The column at which searching starts. Integer. If omitted, searching starts from column 1.

### *finish-col*

The column at which searching ends. Integer greater than the start column. If omitted, searching finishes at column 80.

### **FIRST**

Begin search at lowest address, and look for search string in a forward direction.

### **LAST**

Begin search at highest address, and look for search string in a reverse direction.

### **NEXT**

Begin search at current address, and look for search string in a forward direction.

### **PREVIOUS**

Begin search at current address, and look for search string in a reverse direction.

The function of this command is essentially the same as the ISPF editor FIND command. The search begins at the first source line shown on the screen; the target code, if found, is displayed at the top of the screen.

Unless otherwise qualified, the search is performed from the current address, in the direction last specified.

### **Examples**

```
FIND string

f 'text'
f text
f text

f info first
f init( next
f * prev
f bit( last

find =3 'window 3'
```

**Return codes**

- 0 Operation successful
- 1 Missing keyword
- 2 Keyword truncated
- 3 Keyword unknown
- 5 Arguments are invalid
- 6 Specified string was not located or the search was not conducted

**FIRST**

Displays the source code corresponding to the lowest memory address.

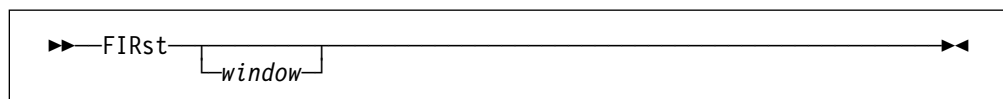
**window**

A Disassembly window. Select by a Window Specification or by placing the cursor in the window. If omitted and the cursor is not in a Disassembly window, uses the first Disassembly window.

**Return codes**

- 0 Operation successful

**FIXED**

Sets or queries the format in which the data for fixed binary variables are displayed.

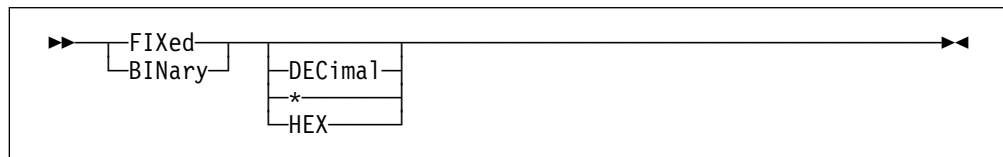
**DECIMAL**

Fixed binary variables are displayed in decimal. This is the initial value.

- \* Fixed binary variables are displayed in the initial format (DECIMAL).

**HEX**

Fixed binary variables are displayed in hexadecimal.

If the display format setting is not specified, the current display format for fixed binary variables is shown in a message.

**Return codes**

- 0 Operation successful
- 2 Keyword truncated
- 5 Not valid fixed binary variable display format

## FLOAT

Sets or queries the format in which the data for float variables is displayed.

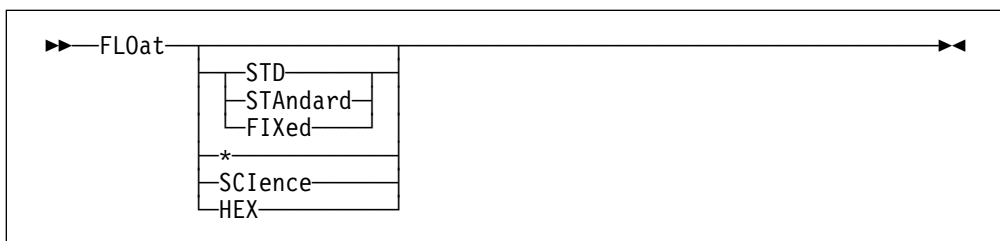

### STD | STANDARD | FIXED

Float variables are displayed in fixed-point (or standard) format - for example as 145.0056. This is the initial value.

- \* Float variables are displayed in the initial format (STD).

### SCIENCE

Float variables are displayed in scientific format - for example as 1.450056E+02.

### HEX

Float variables are displayed in hexadecimal. Use this option to display binary floating-point variables.

If STD is selected, and the number cannot be displayed in standard format, it is displayed in scientific format.

Numbers may be entered in either fixed-point or scientific format when FIXED or SCIENCE formats are selected.

If the display format setting is not specified, the current display format for float variables is shown in a message.

### Return codes

- 0 Operation successful
- 2 Keyword truncated
- 5 Not valid float variable display format

## FMT

The FMT command is a synonym of the FORMAT command. For details, see "FORMAT" on page 115.

## FOLLOW

Makes a Dump window follow the contents of a register or 4-byte storage location as program execution progresses.

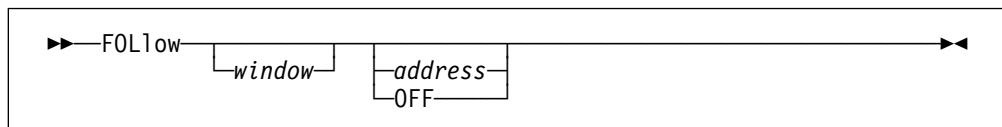

*window*

A Dump window. Select the window by a Window Specification or by placing the cursor in the window. If omitted and the cursor is not in a Dump window, uses the first Dump window.

*address*

The address to be followed. If an expression, the expression is used to provide the address.

If omitted, the address is determined from the cursor position. If it is not possible to determine an address from the cursor position (for example when the cursor is on the command line and the command line is empty), the current follow state of the selected window is displayed.

If R0 to R15, the indicated register's contents determine the starting DUMP address as target program execution progresses.

The argument "R1" means follow the contents of R1, but the argument "0(R1)" means follow the contents of the 4-byte storage area now pointed to by R1.

If no register is specified, is the address of a 4-byte storage area whose contents are to determine the area to be shown in the selected Dump window as program execution progresses. This includes addresses specified by means of cursor position. The 4-byte storage area need not be aligned.

**OFF**

Following is turned off for the window. The window contents change to reflect any change in the contents of the current address.

Each open Dump window can have its own follow address or none at all.

**Return codes**

- 0 Operation successful
- 5 Syntax or other error in expression
- 6 Specified address exceeds the current virtual memory size

**FORMAT**

Controls the way in which a variable is displayed, or shows the display format for the variable.

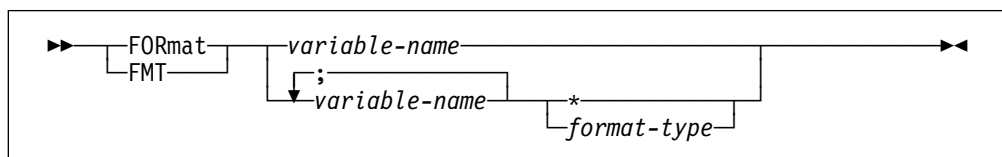

*variable-name*

The variable for which the format is being set.

If only one variable is supplied, and there are no following parameters, then a

message is displayed. The message indicates the display format for the variable.

- \* The variables listed inherit their display format from the current display format for the underlying variable classes.

*format-type*

The display format for the listed variables.

Must be appropriate to the underlying data classes of the variables:

**Binary float**

HEX

**Bit** BITIHEX

**Char** EBCDICIASCIIICHARIHEXIPACKEDZONED

**Fixed** DECIMALIHEX

**Hexadecimal float**

STDISTANDARDIFIXEDISCIENCEIHEX

**Packed Decimal**

DECIMALIHEX

**Zoned Decimal**

DECIMALIHEX

See the following commands for more details:

- “BIT” on page 94
- “CHARACTER” on page 99
- “FIXED” on page 113
- “FLOAT” on page 114
- “PACKED” on page 156
- “ZONED” on page 200

The format in which a variable is displayed is set in two ways:

1. With the appropriate IDF command to change the default display format for the *all* variables within the fundamental data type (or class) to which the variable belongs
2. With the FORMAT command, to specify an explicit display format for this particular variable. This overrides the class display format.

**Return codes**

- 0 Operation successful
- 2 Keyword truncated
- 5 Not valid display format for specified variables

Changes the contents of the Floating Point Control Register (FPC).

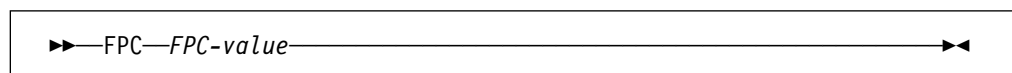

*FPC-value*

The new FPC value. From one to eight hexadecimal digits, right justified.

**Examples**

```
SET FPC 0 FE430000
```

**FPR**

Changes the contents of a Floating Point Register (FPR).

```
▶▶—FPR—FPR-number—FPR-value————▶▶
```

*FPR-number*

The FPR number; 0, 2, 4, or 6.

**Note:** For OS/390 systems with binary floating point support, the FPR number can be from 0 to 15.

*FPR-value*

The new FPR value. From one to sixteen hexadecimal digits, right justified.

**Examples**

```
SET FPR 0 FE43000000000000
```

**GLOBALS**

Displays information about Global Storage stems.

```
▶▶—GLObals————▶▶
```

The LSM Information window containing the GLOBALS display is closed if you issue another GLOBALS command.

To define Global Storage areas, see “SET GLOBAL STEM” on page 175.

The GLOBALS command is meant primarily for debugging situations, or for verifying that IDF understood your commands.

**Return codes**

- 0 Operation successful
- 6 There are no Global Storage stems defined.

**GOTO**

Evaluates an expression and places it in the address portion of the Program Status Word (PSW).

```
▶▶—GOTO—expression————▶▶
   |_____|
   | PSW |
```

## GPACK

*expression*

Specify as an address expression or by the cursor position.

### Return codes

- 0 Operation successful
- 1 No address specified
- 5 Syntax or other error in expression
- 6 Conditions do not permit completion of command

---

## GPACK

Returns the Global Storage data storage areas that no longer contain Global Storage stem data to the operating system free storage pool.

▶▶ GPack ◀◀

The GPACK command helps when free storage is at a premium.

### Return codes

- 0 Operation successful

Other

Error occurred while packing Global Storage data storage areas. This is most likely caused by an overlay of the Global Storage data AREA control information by an errant application program under test.

---

## GPR

Changes the contents of a General Purpose Register (GPR).

▶▶ GPR—*register-number*—*expression* ◀◀

*register-number*

The GPR number. An integer from 0 to 15.

*expression*

The new GPR value. Values are right-justified with leading zeroes.

### Examples

SET GPR 2 ALLOPEN+X'44'

---

## GSTATUS

Displays information about the storage used to contain the Global Storage stem data which was loaded with SET GLOBAL STEM commands.

▶▶ GStAtus ◀◀

The LSM Information window containing the GSTATUS display is closed if you issue a GSTATUS command when the window is open. If not opened, it is opened.

The information includes:

- number of Global Storage stems
- Global Storage storage consumption (total, direct, pooled)
- Global Storage storage pool utilization, including the number of areas in the pool that are unused

The GSTATUS command helps when free storage is at a premium.

When Global Storage data is removed from storage with DROP GLOBAL, the storage areas which contained the extract data are retained for use by later SET GLOBAL stemname commands. Use the GPACK command to return to the operating system free storage pool those storage areas that no longer contain Global Storage data.

### Return codes

0 Operation successful

---

## HIDE

Controls the display of source code and disassembly.

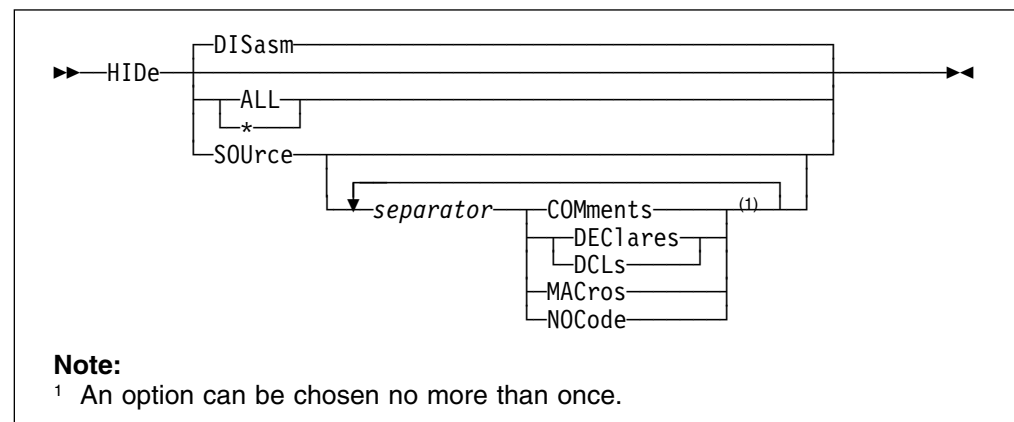

### DISASM

Show source code only, without interspersed assembler code.

### ALL | \*

Show disassembled assembler code only, without source code. The display of comments, declarations, macro expansions, and source lines with no corresponding object code is also disabled, so that these lines are excluded when source display is later enabled by a SHOW SOURCE or SHOW BOTH command. These may be enabled by appropriate SHOW commands.

### SOURCE

Show disassembled assembler code only, without source code.

### COMMENTS

Exclude block comment source when source code is displayed.

## HISTORY

### SEPARATOR

A comma, blank or semicolon. Separates SOURCE and its suboptions.

### DECLARES | DCLs

Exclude declaration source when source code is displayed.

### MACROS

Exclude macro expansion source when source code is displayed.

### NOCODE

Exclude source lines with no corresponding object code when source code is displayed.

The HIDE command assumes that everything is showing, then excludes (hides) whatever you specify. Everything else is then shown, regardless of whether it is shown or hidden. "SHOW" on page 179 provides an alternative means of displaying and hiding items.

### Return codes

- 0 Operation successful
- 2 Keyword truncated
- 5 Invalid information type keyword

---

## HISTORY

Allows review of the history information maintained by IDF when the PATH or PATHFILE option is set.

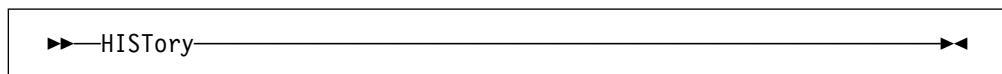

IDF maintains a history of the last 1,023 instructions executed, and the order in which they were executed. HISTORY is only valid when the PATH or PATHFILE option is ON.

When the HISTORY command is executed, an arrow is placed beside the last instruction that was executed. This arrow appears on the right side of the screen, just to the left of the instruction count in the first Disassembly window. The arrow is only displayed against the disassembled assembler code. If the Disassembly window is displaying source code, then you need to issue the SHOW DISASM command to see the arrow.

While the HISTORY arrow is shown in the window, the PREVIOUS and NEXT commands do not scroll the open windows on the screen. Instead, they move the arrow to the previously executed instruction or to the following instruction.

The display remains in this state until a DUMP, DISASM, RUN, or STEP command is executed.

This lets you review the series of instructions that lead to an incorrect result.

**Return codes**

- 0 Operation successful
- 6 PATH option is not ON

**ICOUNT**

Displays the number of instructions executed since the last ICOUNT command.

```
▶▶—ICount—————▶▶
```

After the number is displayed, it is reset to zero. If the PATH option was not set ON, it is set on by the ICOUNT command.

**Return codes**

- 0 Instruction execution count successfully displayed

**KWDSYN**

Defines a synonym of an IDF keyword.

```
▶▶—KWDSYN—oldkwd—newkwd—————▶▶
```

*oldkwd*

The existing IDF keyword. It may be abbreviated to the permitted minimum.

*newkwd*

The overriding synonym. It can have a length different from the IDF keyword it is a synonym of. Specify its minimum abbreviation by putting that part of the new keyword in upper case.

The synonym does not replace the IDF keyword, but it is recognized as the IDF keyword and given all its properties.

**Examples**

- The following command equates the keyword DUMP with the keyword DUMP. However, the new keyword has a minimum abbreviation of D, where the old one's minimum abbreviation was DUMP.

```
set kwdsyn dump Dump
```

- The following command replaces the keyword DISASM with SOURCE.

```
SET KWDSYN DIS SOURCE
```

**LANGUAGE +**

Scrolls information in an LSM Information window.

```
▶▶—LANguage— [ window ] [ + ] [ - ] [ scroll-number-of-lines ]—————▶▶
```

## LANGUAGE COLOR

### *window*

A LSM Information window. Select by a Window Specification or by placing the cursor in the window. If a Window Specification is not present and the cursor is not in a LSM Information window, uses the first LSM Information window.

- + Scroll forward.
- Scroll backwards.

### *scroll-number-of-lines*

The number of lines to scroll (forwards or backwards).

The default value is the scroll amount specified by the last LANGUAGE SCROLL command (see “LANGUAGE SCROLL” on page 128).

Many IDF commands provide user feedback in the form of messages which are displayed in a dedicated area above the IDF command line. Some messages provide sufficient information, for example, when an error occurs, but other commands need more space for displays, for example, VARIABLE, STRUCTURE, and LANGUAGE STATUS.

To handle this situation, IDF provides many LSM Information windows. The first LSM Information window opens automatically when needed, and you can open more with the IDF OPEN command.

There may still not be enough screen lines to display all of the information.

In this situation, IDF provides a “More: + –” indicator in the upper right corner of each LSM Information window. You can now scroll the LSM Information window in IDF with the LANGUAGE + and LANGUAGE – commands.

LANGUAGE + scrolls the LSM display forward, and reissues the current LSM command. When the last line is displayed, the message is not issued, and further forward scrolling does not occur.

A LANGUAGE + command is automatically issued by IDF when the cursor is within the LSM Information window, and the NEXT IDF command is issued.

A LANGUAGE – command is automatically issued by IDF when the cursor is within the LSM Information window, and the PREVIOUS IDF command is issued.

### **Return codes**

- 0 Operation successful
- 2 Keyword truncated
- 5 Arguments are invalid

---

## LANGUAGE COLOR

Controls the color used to display the source code.

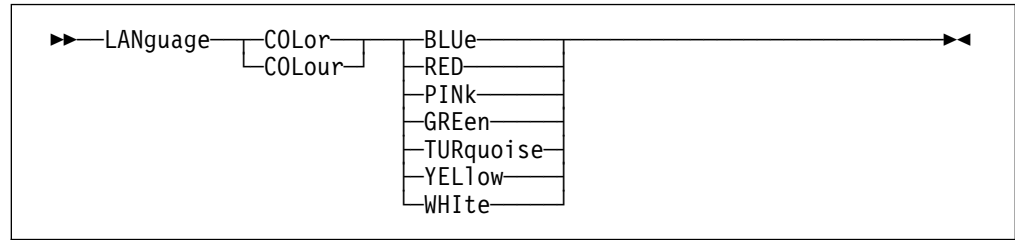

The available colors are:

- BLUE
- RED
- PINK
- GREEN
- TURQUOISE
- YELLOW
- WHITE

Initially, source code is displayed in the color you have specified for IDF display of text data.

### Return codes

- 0 Operation successful
- 1 Missing keyword
- 2 Keyword truncated
- 5 Not valid color keyword

---

## LANGUAGE COMMENTS

Enables or disables the block comment display.

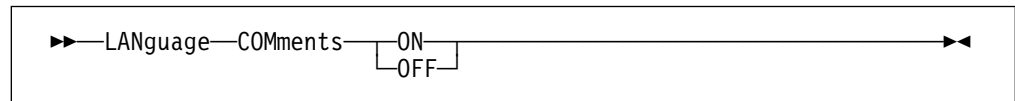

### ON

Block comment display enabled.

### OFF

Block comment display disabled.

---

## LANGUAGE DEBUG

Displays line-mode debug information for all interactions on the LSM interface.

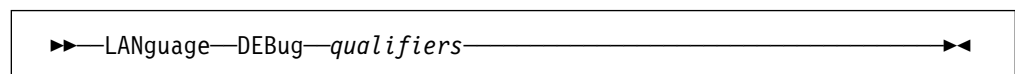

This command is used for debugging the IDF Language Support internal interfaces.

It is not intended as a general user interface.

## LANGUAGE DECLARES

### *qualifiers*

Options that limit this information to specific categories.

### **Return codes**

- 0 Operation successful
- 1 Missing keyword
- 2 Keyword truncated
- 3 Keyword unknown

---

## LANGUAGE DECLARES

Enables or disables declare display.

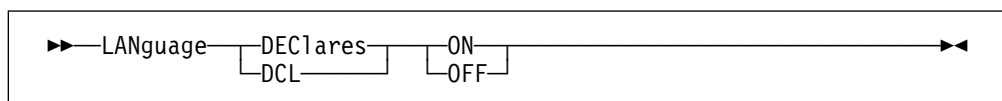

### **ON**

Declare display enabled.

### **OFF**

Declare display disabled.

---

## LANGUAGE DROP

This command removes language extract data from storage, freeing the space for reuse by new extract files loaded by subsequent LANGUAGE LOAD commands.

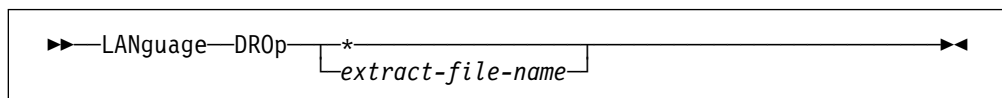

- \* All extract files in memory are removed from storage.

### *extract-file-name*

The extract file name specifying the loaded compiles to be removed from storage. All compiles with the extract file name matching this value are removed.

If no extract data matches the argument, an error message is displayed.

### **Return codes**

- 0 Operation successful
- 1 Missing keyword
- 2 Keyword truncated
- 5 Arguments are invalid
- 28 The specified extract file was not loaded with LANGUAGE LOAD

## LANGUAGE LOAD

Loads an extract file, optionally associating it with an executable module.

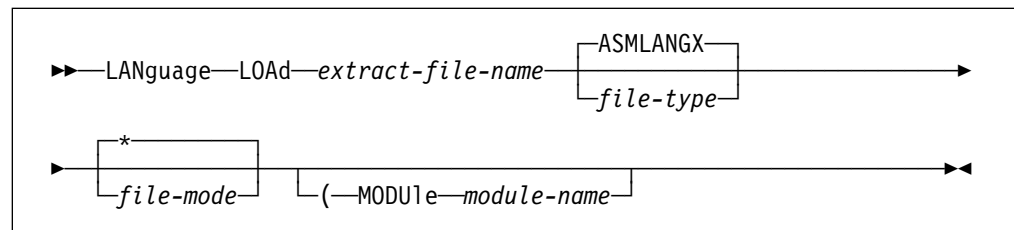

### *extract-file-name*

The extract file that is loaded.

- On CMS, the file name (FN) of the extract file created by ASMLANGX.
- On TSO, the PDS member name of the extract file created by ASMLANGX. For TSO sequential files (DSORG(PS)), a dummy name must be specified, but is ignored.
- On VSE, the librarian member name of the extract file created by ASMLANGX.

If not specified (the file type default accepted) IDF uses the entries in the XPATH to locate the extract file.

### **ASMLANGX**

The default file type for extract file (normally not specified).

### *file-type*

The file type of the extract file.

- On CMS, the file type (FT) of the extract file created by ASMLANGX.
- On TSO, the DD name allocated to the extract file created by ASMLANGX.
- On VSE, not used.

### *file-mode*

The file mode of the extract file.

- On CMS, the FM of the extract file created by ASMLANGX.
- On TSO, not used, ignored if specified.
- On VSE, not used, ignored if specified.

\* Indicates that all disks are to be searched in order.

### **MODULE**

Indicates that a module name is being specified.

### *module-name*

The module with which to associate the extract file.

Multiple instances of the same extract file may be loaded as long as each specifies a different *module-name*.

If a module is *not* specified:

- If the extract file contains information that needs load-time resolution the module defaults to the qualified target module.

- Otherwise, the extract file is generic, where it is freely associated with any relevant code sections in all MODULES.

The LANGUAGE STATUS command (see “LANGUAGE STATUS” on page 129) shows the module name specified when an extract file is loaded.

The MAP command (see “MAP” on page 139) shows the association between extract files and program code sections.

### Return codes

<b>0</b>	Operation successful.
<b>1</b>	Missing keyword.
<b>2</b>	Keyword truncated.
<b>3</b>	Keyword unknown.
<b>28</b>	File not found.
<b>29</b>	File was already loaded with the same module specification.
<b>201</b>	The input file is from a version of ASMLANGX that is not supported by the LSM.
<b>202</b>	Duplicate or invalid scope record in input file.
<b>203</b>	More source statements in file than indicated by the scope record.
<b>204</b>	Duplicate or invalid number-of-symbol record in the input file.
<b>205</b>	Symbol id number larger than maximum symbol number was encountered in a symbol record.
<b>206</b>	Symbol id number larger than maximum symbol number was encountered in an array record.
<b>207</b>	File contains no records of a known format.
<b>208</b>	Duplicate or invalid check record in the input file.
<b>209</b>	Duplicate or invalid address expression record in the input file.
<b>210</b>	Duplicate or invalid structure layout record in the input file.
<b>211</b>	Symbol id number larger than maximum symbol number was encountered in a respecify record.
<b>212</b>	Address expression id number larger than maximum address expression number or symbol id number larger than the maximum symbol number was encountered in an address expression record.
<b>213</b>	Address expression id number larger than maximum address expression number or symbol id number larger than the maximum symbol number was encountered in an address expression respecify record.
<b>214</b>	Symbol id number larger than maximum symbol number was encountered in a symbol optimization record.
<b>215</b>	Symbol id number larger than maximum symbol number was encountered in a structure layout record.
<b>216</b>	Errors were encountered unpacking a source record.
<b>217</b>	Base debugger (IDF) version is too low to support the required function.
<b>218</b>	Module private-code CSECT was not found. The functions in the extract file cannot be located in the IDF symbol table.
<b>219</b>	Scope ID record present, but it was not preceded by a Scope record.
<b>220</b>	Symbol id number larger than maximum symbol number was encountered in a scope ID record.
<b>221</b>	Duplicate or invalid CSECT record in the input file.
<b>222</b>	CSECT record expected but not found in the input file.
<b>223</b>	CSECT id number larger than maximum CSECT number was encountered in a PC (Private Code) lookup record.
<b>224</b>	CSECT id number larger than maximum CSECT number was encountered in a source record.

- 225** CSECT id number larger than maximum CSECT number was encountered in a symbol record.
- 226** Symbol id number larger than maximum symbol number was encountered in a constant record.
- 227** Error occurred building the statement offset table.
- 237** Duplicate or invalid On Event Map record in the input file.
- 238** Duplicate or invalid Secondary Entry Point record in the input file.
- 239** Symbol id number larger than maximum symbol number was encountered in a Secondary Entry Point record.
- 240** Duplicate or invalid External Symbol List record in the input file.
- 241** Symbol id number larger than maximum symbol number was encountered in an External Symbol List record.
- 242** Duplicate or invalid Symbol Display Format record in the input file.
- 243** Symbol id number larger than maximum symbol number was encountered in a Symbol Display Format record.
- 244** Duplicate or invalid Class Layout record in the input file.
- 245** Symbol id number larger than maximum symbol number was encountered in a Class Layout record.
- 246** Duplicate or invalid Class Hierarchy record in the input file.
- 247** Symbol id number larger than maximum symbol number was encountered in a Class Hierarchy record.
- 248** Symbol id number larger than maximum symbol number was encountered in an OverLoaded Symbol record.
- 249** Duplicate or invalid Linkage Convention record in the input file.
- 250** Symbol id number larger than maximum symbol number was encountered in a Linkage Convention record.
- 251** Symbol id number larger than maximum symbol number was encountered in a Parameter List record.
- 252** Duplicate or invalid Compile Information record in the input file.
- 253** Duplicate or invalid OverLoaded Entry Stmt record in the input file.
- 254** Symbol id number larger than maximum symbol number was encountered in an Overloaded Entry Stmt record.

**1xxx**

Error occurred during scan of the extract file.

The values for xxx are:

- 1yy** yy is the RC from File\_Open
- 2yy** yy is the RC from File\_Read
- 4yy** yy is the RC from File\_Point
- 5yy** yy is the RC from Mem\_Allocate
- 6yy** yy is the RC from Mem\_Free
- 7yy** yy is the RC from File\_Close
- 8yy** yy is the RC from File\_Note

**LANGUAGE MACROS**

Enables and disables the display of assembler source generated by macros.

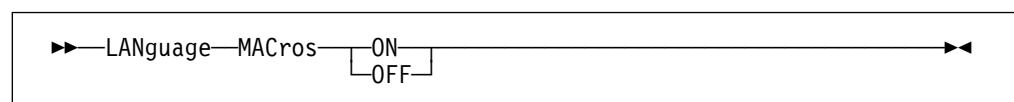

## LANGUAGE OPTIONS

### ON

The display of assembler source generated by macros is enabled.

### OFF

The display of assembler source generated by macros is disabled. This is the initial setting.

For more details see the command description of SHOW and HIDE.

---

## LANGUAGE OPTIONS

Displays the current value for each IDF Language Support setting.

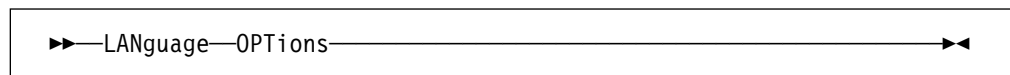

Displays the current value of the following options or settings:

- Show
- Debug
- Scroll
- Detail
- Major
- Settings save stack nesting level
- Checks
- LSM stem
- EXLIMIT
- XPATH
- Bit variable format
- Char variable format
- Fixed variable format
- Float variable format
- Packed variable format
- Zoned variable format

The OPTIONS command is meant primarily for debugging situations, or for checking that IDF understood your commands.

The LSM Information window containing the LANGUAGE OPTIONS display closes if you issue a second LANGUAGE OPTIONS command.

### Return codes

0 Operation successful

---

## LANGUAGE SCROLL

Sets the default for the number of screen lines by which an LSM Information window is scrolled when the LANGUAGE command is issued.

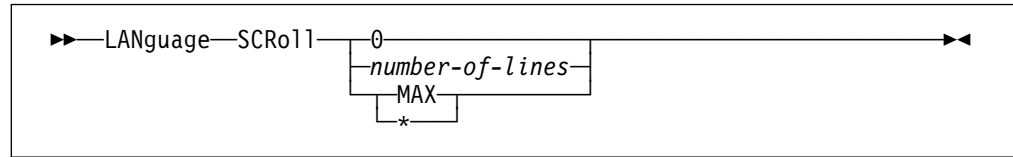

**0** Scrolling is disabled.

*number-of-lines*

Scrolling is by this number of lines

**MAX | \***

Scrolling is by the maximum number of lines (the current size of the LSM Information window)

The current scroll amount value is displayed as part of the LANGUAGE OPTIONS command information.

**Return codes**

- 0 Operation successful
- 2 Keyword truncated
- 5 Arguments are invalid

The current scroll amount value is displayed as part of the LANGUAGE OPTIONS command information.

**LANGUAGE STATUS**

Displays information about the extract files that were loaded with LANGUAGE LOAD commands.

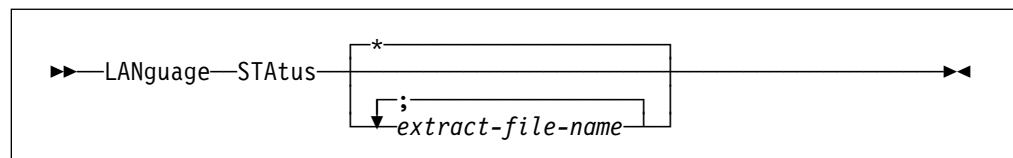

**\*** Information about all the currently loaded (with LANGUAGE LOAD) language files is displayed.

*extract-file-name*

Information about the compiles contained in this extract file is displayed.

The LSM Information window containing the LANGUAGE STATUS display is closed if you issue a LANGUAGE STATUS command without operands and the current display is for the same command with a null argument.

The LANGUAGE STATUS command is meant primarily for debugging situations, or for verifying that IDF understood your commands.

To display the current value of the IDF Language Support settings, use the LANGUAGE OPTIONS command.

## LANGUAGE STEM

### Return codes

- 0 Operation successful
- 28 The specified extract file was not loaded with LANGUAGE LOAD.

---

## LANGUAGE STEM

Alters the name of the REXX stemmed variable array which is used to return information to an IDF macro as a result of all subsequent EXTRACT LANGUAGE commands, as well as a number of other EXTRACT commands.

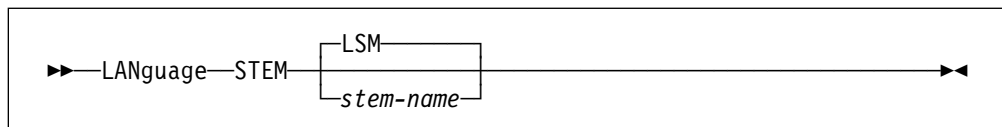

### LSM

The default value of the REXX stem name.

#### *stem-name*

The REXX stem name. It must be between 1 and 8 characters, with the first character alphabetic.

The current LANGUAGE STEM setting can be displayed with the LANGUAGE OPTIONS command, and retrieved with the EXTRACT LANGUAGE STEM command.

For more information, see Chapter 15, “EXTRACT Command” on page 222.

### Return codes

- 0 Operation successful
- 2 Keyword truncated
- 5 Arguments are invalid

---

## LANGUAGE VERSION

Displays the IDF Language Support version information.

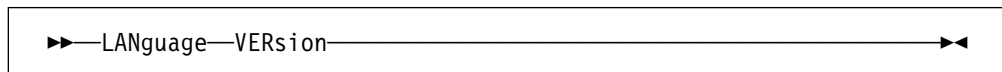

The information is in the form:

ASMLANG Vn.Rn.nn (generated ccyymm dd hh:mm)

### Return codes

- 0 Operation successful

## LANGUAGE XPATH (CMS and TSO)

Defines the extract file search path file type (TSO DD name) information.

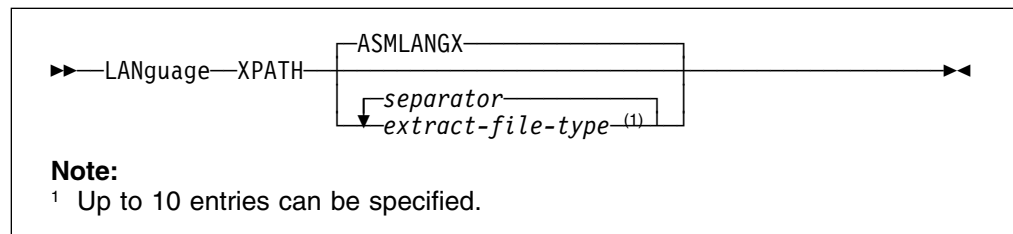

### ASMLANGX

The default extract file search path.

#### *extract-file-type*

The extract file search path.

#### *separator*

A comma, blank or semicolon. Separates extract file types.

The following characters are allowed in XPATH entries:

- A–Z (or a–z)
- @, #, \_, \$, -, +
- 0–9 (*not* allowed as first character of an entry)

This information is used to locate extract files for which the extract file type (TSO DD name) was not explicitly specified. The XPATH entries are searched in the supplied order.

The LANGUAGE OPTIONS command displays the current XPATH information.

The ability to define the extract file search path gives you full control of the extract file loading process. It is easy to support the coexistence of many versions of a target program.

### Return codes

- 0 Operation successful
- 2 Keyword truncated
- 5 Arguments are invalid

## LAST

Displays source code starting at the highest available address.

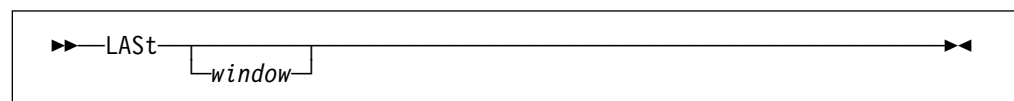

#### *window*

A Disassembly window. Select by a Window Specification or by placing the cursor in the window. If omitted and the cursor is not in a Disassembly window, uses the first Disassembly window.

**Return codes**

0 Operation successful

**LASTMSG**

Displays the last two messages issued in the message areas.

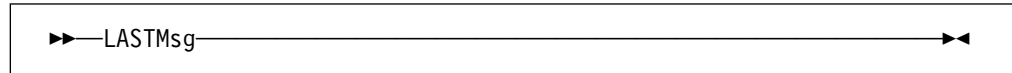

**Return codes**

0 Operation successful

**LEFT**

Scrolls an open window left.

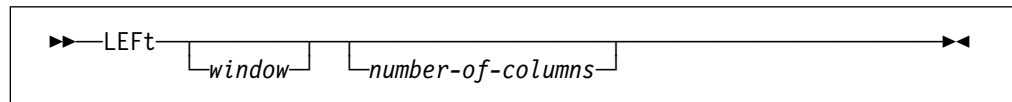

*window*

A window. Select by a Window Specification or by placing the cursor in the window. If omitted and the cursor is not in a scrollable window, then all scrollable windows are scrolled.

*number-of-columns*

The number of columns by which the window is to be scrolled. This may be specified as:

- An integer
- An integer prefixed by a +
- An integer prefixed by a –, specifying the number of screen columns by which the window is to be scrolled to the *right*.

If omitted, each window to be scrolled is scrolled by the current number of data columns for that window.

This command is usually only meaningful when a Disassembly window is open. However, you can also scroll windows made smaller with the SIZE command.

**Return codes**

- 0 Operation successful
- 5 Arguments are invalid
- 6 Command issued when it has no meaning

## LIBE (CMS and TSO)

Controls the source of the target program which IDF is to load.

```
▶▶—LIBE—file-name————▶▶
```

### *file-name*

The file to be loaded.

- **CMS**

LIBE indicates that the target program should be loaded from an OS-style LOADLIB rather than from the usual CMS-style MODULE file.

### *file-name*

The file name of the LOADLIB to be used.

If this file name is not present in the list of files declared with the CMS GLOBAL LOADLIB command, it is added as the first library.

\$ Indicates that the LOADLIB was declared through the CMS GLOBAL LOADLIB command. **CMS**

- **TSO**

- LIBE is used to explicitly control the loading of the target Load Module.
- A single parameter is needed. It may be either:
  - The DD name of the PDS containing the Load Module.
  - \$ to indicate that standard OS Load Module search order should be used.

- **TSO**

The LIBE command may only be issued from the PROFILE macro, before loading the target program into storage.

### Examples

```
SET LIBE $
SET LIBE mylib
```

## LOAD

---

## LOAD

Loads the target program and associated symbol information into memory.

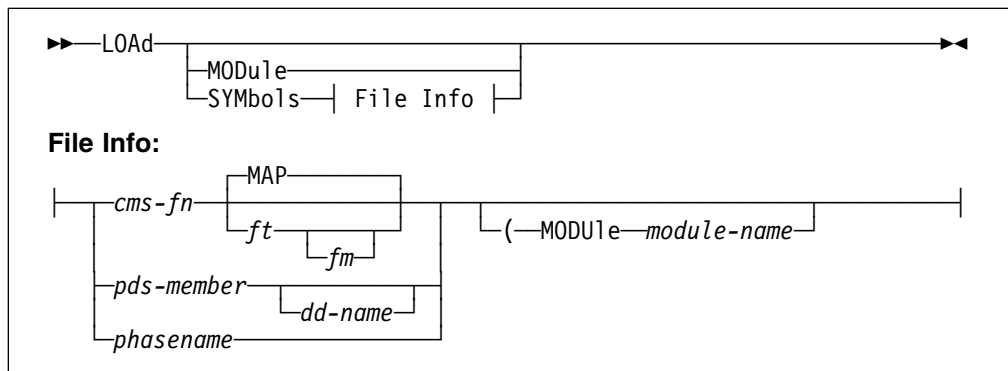

### MODULE

Keyword indicating module-only load.

Only the target module is loaded into storage.

This option may only be used in the PROFILE macro. For more details see “Command Restrictions Related to PROFILE Execution” on page 205.

### SYMBOLS

Keyword indicating symbols-only load.

Only the module symbols are loaded into storage. The following parameters provide more information.

*cms-fn*

CMS file name

### MAP

Default CMS file type

*ft* CMS file type

*fm* CMS file mode

*pds-member*

TSO PDS member name.

*dd-name*

TSO DD name. If omitted, IDF looks in the ISPLLIB or STEPLIB if present. If the LIBE option was used, then that DD name is used as the default. IDF does not look in LPALIB or the MVS link list.

*phasename*

The VSE phase map, as generated by ASMLKEDT.

### MODULE

Keyword to indicate that a module name is supplied. If not supplied, then symbols are loaded for the qualified module.

*module-name*

Module for which symbols are loaded.

If LOAD MODULE or LOAD SYMBOLS is issued by the PROFILE macro, but not both, IDF makes sure that both functions are performed after the profile completes.

For example, if the PROFILE issues LOAD SYMBOLS but does not issue LOAD MODULE, IDF loads the module anyway after the profile is completed.

You can stop IDF from loading the module with the MODULE command.

If no parameters are supplied with this command (the command is simply "LOAD") then both the target module and its associated symbols are loaded into storage. This may only be used in PROFILE macro. For more details see "Command Restrictions Related to PROFILE Execution" on page 205.

### Return codes

0 Target program loaded successfully

Other

An error occurred, see "Message Numbers and Severity Levels" on page 256 for return codes.

### Notes for LOAD SYMBOLS for CMS

The underlying assumption for the IDF processing which loads symbols is that the symbol information is found as INVALID CARD images in the LOAD MAP file, interspersed with entrypoint addresses. You can use the LOAD SYMBOLS command to load symbol information from a TEXT file rather than a renamed LOAD MAP if you wish, but you have to perform some more setup for this case.

When loading symbol information directly from a TEXT file, you must first load all of the applicable TEXT files by means of the LOAD SYMBOLS command, then you must issue a SYMBOL command to define the offset-within-module for each CSECT.

An example profile to perform this kind of operation follows, but you probably want something more elaborate to prevent recoding the addresses within the profile each time you rebuild the program:

```
/* load symbols directly from TEXT files */
'LOAD SYMBOLS ASMPARM TEXT'
'LOAD SYMBOLS ASMSCAF TEXT'
'SET SYMBOL (ASMPARM) ASMPARM 00000000 00000000 00000060 E F 01'
'SET SYMBOL (ASMSCAF) ASMSCAF 00000000 00000060 00000400 E F 01'
'SET SYMBOL (ASMSCAF) ASMSUBCM 0000028E 000002EE 00000000 E F 24'
```

*Figure 20. Loading Symbols Directly From TEXT Files*

The records in the LOAD MAP file which IDF uses to determine the start addresses of various CSECTs have the following format (in some cases you may want or need to build the map manually):

**Col 1** Blank

**Col 2-9** Symbol name (upper case)

**Col 10** Blank

**Col 11-12** If the symbol marks the start of a CSECT, these columns should contain the characters SD, otherwise they should be blank.

## LOAD

**Col 13** Blank

**Col 14-19** The hexadecimal address associated with this symbol.

**Col 20-\*** Blank

---

**LOCATE**

Locates a string and displays the section of code where it occurs.

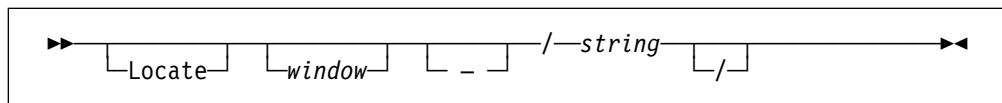
**window**

A Disassembly window. Select by a Window Specification or by placing the cursor in the window. If omitted, and the cursor is not in a Disassembly window window, uses the first Disassembly window.

- Search direction is up, rather than down.

**string**

The string to be searched for. Include the trailing delimiter “/” when the string has trailing blanks.

Format is essentially the same as the XEDIT LOCATE command. The search begins at the first source line shown on the screen; the target code, if found, is displayed at the top of the screen.

**Examples**

```
loc /procedure

loc -/end;

l /declare /

/init(

/first use/

-/gobackward

loc =3 /window 3/
```

**Return codes**

- 0 Operation successful
- 1 Missing search string
- 6 No extract data files containing source code were loaded with LANGUAGE LOAD.

---

**LOCATION**

Sets main storage to the contents of REXX variable MEMAREA.

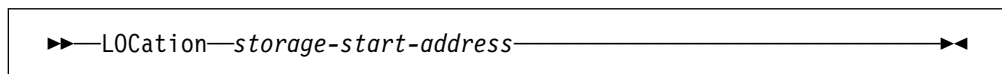

## LOCATION ALET

### *location-start-address*

An expression specifying the storage start address.

If the expression contains an Access Register then the storage that is modified is in the dataspace identified by the ALET in the referenced Access Register.

The SET LOCATION command lets you modify storage within your program's defined limits. If the TRACEALL or RISK option is ON, you may be able to modify storage beyond the defined limits.

For more details on your program's defined limits and how to change them, see (for CMS) "Your Program's Defined Limits" on page 50, (for TSO) "Your Program's Defined Limits" on page 42 and (for VSE) "Your Program's Defined Limits" on page 57.

### Examples

```
SET LOCATION plist
SET LOCATION 0(R1)
SET LOCATION 0(AR2)
```

### REXX Variables Read

**MEMAREA** new contents of the specified memory area

---

## LOCATION ALET

Sets storage in a dataspace to the contents of REXX variable MEMAREA.

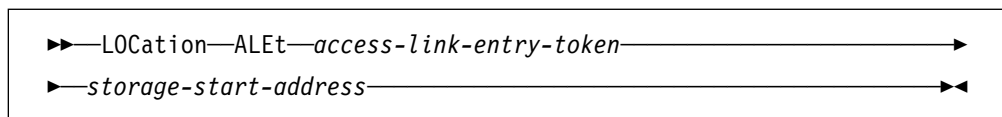

### *access-link-entry-token*

A token identifying the ALET. Must be a 1 to 8 character hexadecimal value.

### *storage-start-address*

An expression resolving to a storage area start address within the dataspace.

You must be in an ESA environment for this command to work.

### Examples

```
SET LOCATION ALET 10003 X'1000'
SET LOCATION ALET 10004 0(R1)
```

### REXX Variables

**MEMAREA** new contents of the specified memory area

---

## MACRO

Issues an IDF macro.

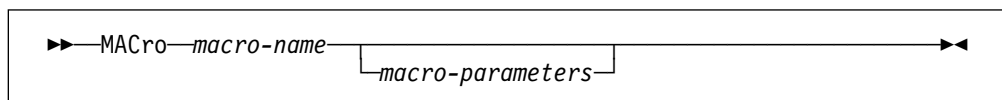

*macro-name*

The name of the macro.

*macro-parameters*

Arguments for the macro.

Execute the MACRO command by pressing a PF key, by typing on the command line when the COMMAND command is invoked, or by issuing as a command from another macro.

**Return codes**

If the macro is found, its return code is propagated to the caller.

The following return codes are generated by IDF:

- 3 Macro not found
- 1 No macro name specified
- 2 Macro name exceeds 8 characters
- 5 Arguments to macro exceed 79 characters in length

---

**MAJOR**

Enables and disables the display of data for the structure major component.

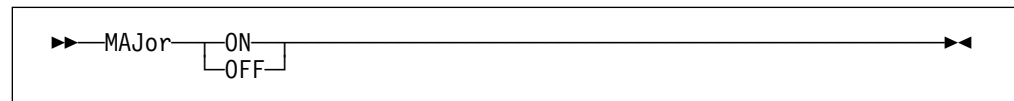
**ON**

Enables the display of structure major component data.

**OFF**

Disables the display of structure major component data. This is the initial setting.

**Return codes**

- 0 Operation successful
- 1 Missing keyword
- 2 Keyword truncated
- 3 Keyword unknown

---

**MAP**

Displays the location of modules and code sections known to IDF, and the name of any associated extract file.

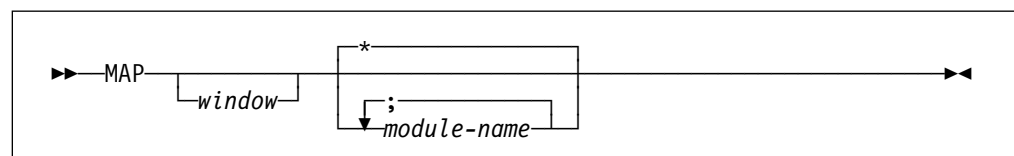

## MAXIMIZE

### *window*

An LSM Information window. Select by a Window Specification or by placing the cursor in the window. If omitted and the cursor is not in an LSM Information window, uses the first LSM Information window.

- \* Displays information for all known modules.

### *module-name*

The module for which information is displayed.

The LSM Information window containing the MAP display is closed if you issue a MAP without operands and the current display is for the same command with a null argument.

The module and code section entries are built (and possibly associated with an extract file) as part of processing the LANGUAGE LOAD command, as well as the DISASM command.

The MAP command is meant primarily for debugging situations, or for verifying that IDF understood your commands.

### **Return codes**

- 0 Operation successful
- 28 The specified module was not defined to IDF

---

## MAXIMIZE

Removes a window from the Minimized Windows Viewer and restores it to its previous position on the display screen.

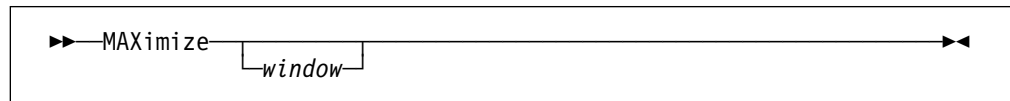

### *window*

The window to maximize. Select by a Window Specification or by placing the cursor in the window name token in the Minimized Windows Viewer.

### **Return codes**

- 0 Operation successful
- 1 No window selected

---

## MINIMIZE

Removes a window from the IDF display, and places an entry representing the window in the Minimized Windows Viewer.

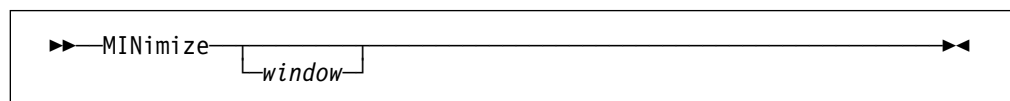

*window*

The window to be minimized. Select it by a Window Specification or by placing the cursor in the window.

**Return codes**

- 0 Operation successful
- 1 No window selected

**MODE (CMS only)**

Sets the file mode IDF uses for CMDLOG or MACROLOG and associated playback operations.

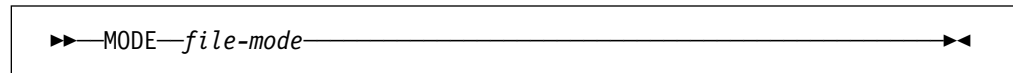

*file-mode*

A CMS file mode specification.

**Examples**

```
SET MODE b
SET MODE A2
```

**MODULE**

Stops IDF loading an executable file into memory.

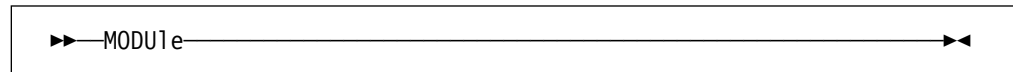

MODULE intended for use by user profiles that need to perform unusual program loading. It can only be issued from an IDF macro or profile.

**Examples**

```
MODULE
```

**MODULE**

Defines the origin and length of a module that was loaded while the original target program was executing.

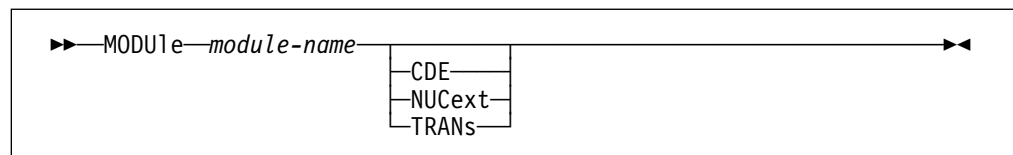

*module-name*

The name of the module that is to have its origin and length defined.

## MODULE BASE

### CDE

TSO only.

Scan the Contents Dictionary Entries (CDEs) in the Job Pack Queue (list of modules loaded for the current job, the TSO session) for an entry corresponding to *module-name*. If no suitable CDE was found, the search continues with a scan of the Link Pack Dictionary Entries (LPDEs) in the Link Pack Area (the list of pre-defined and resident modules).

If a matching CDE or LPDE is found, set up a module definition for *module-name* with appropriate module start address and length values.

### NUCEXT

CMS Only.

Scan the CMS Nucleus Extension Subcommand control block chain and locate an entry for *module-name*.

If an entry is found, set up a module definition for *module-name* with appropriate module start address and length values.

### TRANS

CMS Only.

Check the *module-name* MODULE file to make sure that it is a transient program (has only 1 record).

If *module-name* MODULE is a transient program, set up a module definition for *module-name* with a module start address of X'0E000' and a module length of X'FFF'.

The second argument is the module search type. It is not needed for VSE.

The origin and length are taken from system control blocks.

This command lets you debug many modules at once.

The new module definition is needed before symbols are loaded for modules loaded by the original target.

### Examples:

```
MODULE IDF CDE
MODULE IDFMAIN NUCEXT
```

---

## MODULE BASE

Sets the origin of a module that was loaded while the original target program was executing.

```
►►—MODULE—module-name—BASE—module-start-address—————►◄
```

*module-name*

The name of the module that is to have its origin set.

*module-start-address*

An expression which resolves to the start address value for module *module-name*.

This command lets you debug many modules at once.

The new module definition must be completed with a MODULE SIZE command before symbols are loaded.

See “BASE” on page 93 for information on how to set the base address of the target program specified when IDF was invoked.

### Examples:

```
MODULE ASMLANGX BASE 0(R0)
```

---

## MODULE SIZE

Sets the length of a module that was loaded while the original target program was executing.

```
►►—MODULE—module-name—SIZE—module-length—◄◄
```

*module-name*

The name of the module that is to have its length set.

*module-length*

An expression which resolves to the length value for module *module-name*.

This command lets you debug many modules at once.

The new module definition must be completed with a MODULE BASE command before symbols are loaded.

### Examples

```
MODULE ASMLANGX SIZE X'123000'
MODULE FDISK SIZE F'1024'
```

## MOVE

## MOVE

Moves a window to a new location on the screen.

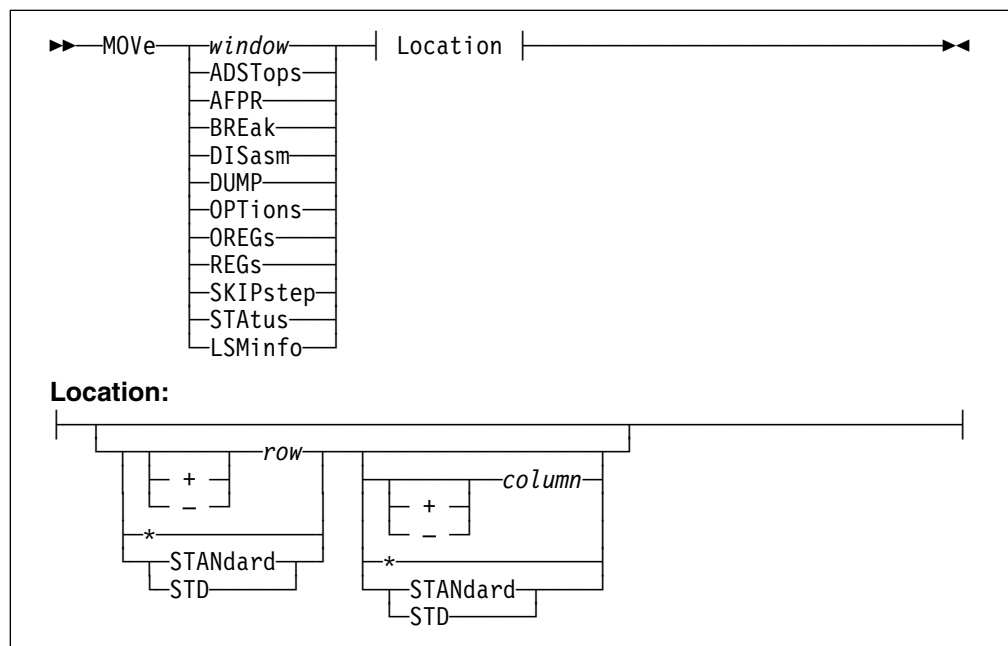

### WINDOW

The window to be moved. Select by a Window Specification, or by placing the cursor in the window.

### ADSTOPS

The AdStops window.

### AFPR

The Additional Floating-Point Registers window.

### BREAK

The Break window.

### DISASM

The Disassembly window with the lowest window id.

### DUMP

The Dump window with the lowest window id.

### OPTIONS

The Options window.

### OREGS

The Old Registers window.

### REGS

The Current Registers window.

### SKIPSTEP

The Skipped Subroutines window.

**STATUS**

The Target Status window.

**LSMINFO**

The LSM Information window with the lowest window id.

*row*

The screen row to which the window is to be moved.

This may be specified by:

- an integer. This is the screen row for the upper left corner of the window. The screen rows are numbered from the top. The top row is row 1.
- an integer prefixed by a +. This is the number of screen rows by which the window is moved down on the screen.
- an integer prefixed by a -. This is the number of screen rows by which the window is moved up on the screen.
- \* The window is kept at the current row. Use this when you want to change the column, but not the row.
- STANdard | STD. This indicates that the standard window row and column position for this window type should be used.

If this parameter is omitted, the position of the cursor on the screen is used as the new location of the upper left corner of the window.

*column*

The screen column to which the window is moved.

This may be specified as:

- an integer. This is the screen column for the left side of the window. The screen columns are numbered from the left. The leftmost column is 1.
- an integer prefixed by a +. This is the number of screen columns by which the window is to be moved to the right on the screen.
- an integer prefixed by a -. This is the number of screen columns by which the window is to be moved to the left on the screen.
- \* The window is kept at the current column. Use this when you want to change the row, but not the column.
- STANdard | STD. This indicates that the standard window row and column position for this window type should be used.

If this parameter is omitted, and the row parameter is specified, the current screen column for this window is maintained.

The MOVE command lets you place open windows in explicit places on the screen. Any window can overlap any other window. However, none of the windows can overlap the Command window. Also, a window cannot be placed such that some of the window is off the screen. If you try this, IDF repositions the window so that all of it stays on the screen.

## MPACK

### Examples

- To move the window 03 origin to row 5 and column 20:  
MOVE =03 5 20
- To move the window in which the cursor is placed to row 8 and column 1:  
MOVE 8 1
- To move the window 01 origin to the current cursor position:  
MOVE =01

### Return codes

- 0 Operation successful
- 1 Window name or Row location missing
- 2 Operand longer than eight characters
- 5 Window name invalid or syntax or other error in expression

---

## MPACK

Returns extract data storage AREAs that do not hold extract data to the operating system free storage pool.

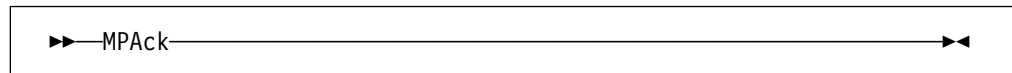

The MPACK command is meant primarily to help when free storage is at a premium.

### Return codes

- 0 Operation successful
- Other  
Error occurred while packing extract data storage AREAs. This is probably caused by an overlay of the extract data AREA control information by an errant application program under test.

---

## MRUN

Executes target program instructions until the next event occurs.

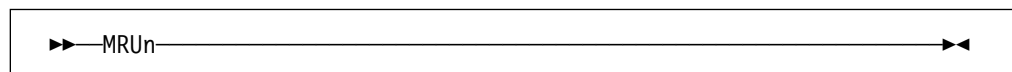

The MRUN command is different to RUN, because the target program is executed *before* control returns to the issuing macro. When RUN is issued from a macro, it has no immediate effect, being processed *after* the macro exits.

After issuing MRUN, the macro can use EXTRACT EVENT to determine what kind of event occurred in the target program.

**CMS** You should ensure that the MRUN command is issued through the LPSW Fastpath addressing environment, which is the default environment established when the IDF macro is entered. Using this interface eliminates any

SVC linkages between REXX and IDF, so that IDF can provide optimum flexibility in what the target program can itself execute under MRUN. “REXX Linkage Considerations” on page 208 provides information concerning the available methods for invoking IDF commands from REXX.

If instead the address ASM environment is used to invoke the MRUN command, REXX uses a CMSCALL (SVC 204) to invoke the MRUN command. This SVC linkage introduces some potential problems in the execution of the target program. These are described below under “MRUN invoked through address ASM on CMS.”

◀ CMS

### Return codes

- 0 Operation successful
- 6 The target program is not yet loaded

## MRUN invoked through address ASM on CMS

If the address ASM environment is used to invoke the MRUN command (or MSTEP, or any other command which causes immediate execution of the target program) on CMS, then REXX uses a CMSCALL (SVC 204) to invoke the MRUN command. This SVC linkage introduces some potential problems in the execution of the target program:

1. If the target program obtains GETMAIN storage during execution under the MRUN command, that storage may be implicitly FREEMAIN'ed again, without warning. This occurs because of the default CMS setting of STORECLR ENDSVC, and the fact that a CMSCALL/CMSRET pair was used in the REXX linkage to the MRUN. CMS is working as designed by implicitly freeing any GETMAIN storage that was obtained between the CMSCALL and CMSRET. This can of course lead to unpredictable behavior of the program's further execution.

The implicit FREEMAIN can be avoided by a CMS SET STORECLR ENDCMD setting, but this in turn introduces another consideration of its own: CMS then honors any STRINIT request. Any MODULE file that is generated with the STR option causes a STRINIT request when that MODULE is executed.

So switching to STORECLR ENDCMD is not a good solution. It is best to leave the default STORECLR ENDSVC. (IDF does not itself alter the current STORECLR setting.) The only complete solution is to make sure that the LPSW Fastpath linkage is used to invoke the MRUN command.

2. If the target program does a CMSCALL to another program, and an event occurs to signal completion of the MRUN, then CMSCALL synchronization is destroyed by IDF's attempt to CMSRET back to REXX to complete the MRUN. CMS treats each CMSRET as being paired to the most recent CMSCALL. The most recent CMSCALL in the above scenario is the one from the target program execution. So instead of returning to the MRUN within REXX as intended, this CMSRET actually returns to the next instruction after the target program's CMSCALL.

IDF cannot compensate for this CMSCALL/CMSRET linkage problem. All it can do is to *detect* when it is about to happen. This is done by recording the current SVC nesting depth at entry to its address ASM command handling, and checking that the nesting is the same just before it returns from that command handling. If not, another SVC depth was created (or destroyed) while executing the target program, and CMS is hopelessly confused if IDF returns. So instead

## MSG

IDF issues a series of messages about the situation, telling you to consult *this* section of the documentation for details. A re-IPL of CMS is needed afterwards.

Exactly the same situation occurs when using LINK or SVC 202 linkage to another program instead of CMSCALL. Again, IDF detects a change in the CMS SVC nesting depth, issues its messages, and needs a re-IPL.

3. If the target program does a DMSKEY NUCLEUS, DMSKEY USER, or DMSKEY LASTUSER which does not specify the NOSTACK option, and an event occurs to signal completion of the MRUN before the corresponding DMSKEY RESET in the target program, then a CMS ABEND occurs, since the change of key appears to have occurred from within IDF and is not restored before returning to the calling function, in this case REXX.

These considerations apply only to an address ASM invocation on CMS. They are of no concern if you use the default LPSW Fastpath interface to invoke the command. With no SVC linkage used in that path, each of these potential problems is bypassed.

---

## MSG

Places text in the next available Command window message display line.

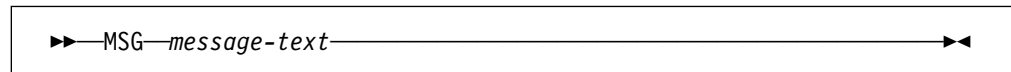

*message-text*

The message text.

If all message display lines are occupied, the current messages scroll up and the new message appears in the bottom display line.

### Examples

SET MSG This is a message

---

## MSGID (CMS and TSO)

Controls the display of the message identifier.

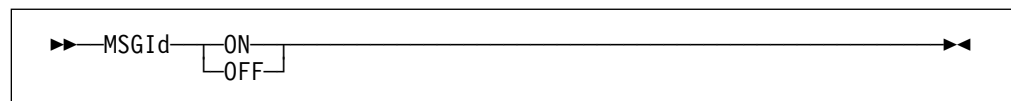

### ON

The message identifier is displayed.

### OFF

The message identifier is not displayed.

The initial setting is based on the execution environment and MVS or OS runtime settings:

- Under CMS, the messages respect the CMS EMSG setting:

**ON** The MSGID option is initially ON  
**TEXT** The MSGID option is initially OFF  
**OFF** The MSGID option is initially ON

- Under TSO, the messages respect the TSO MSGID setting:

**MSGID** The MSGID option is initially ON  
**NOMSGID** The MSGID option is initially OFF

- Under VSE, the MSGID option is always ON.

### Return codes

0 Operation successful  
 1 Missing keyword  
 2 Keyword truncated  
 3 Keyword unknown

---

## MSGMODE

Controls the display of messages during macro execution.

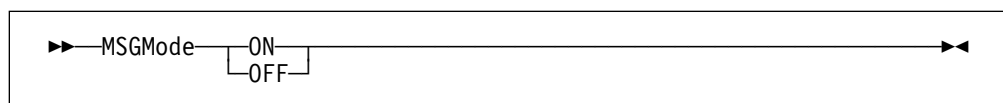

### ON

Enable the display of all messages.

This is the initial setting.

### OFF

Disable the display of specific messages.

The message filtering is dependent on the message severity level. Only I (Informational), W (Warning) and E (Error) messages are suppressed by MSGMODE OFF. All other types of messages are not affected.

When some IDF commands are issued through PF keys, or a command typed on the Command window command line, appropriate status and informational messages are displayed.

During the execution of a macro, these messages may become rather lengthy, hence this command to give you control.

When macro execution is complete, the MSGMODE setting is returned to the default ON value.

The most recent 10 messages, including those suppressed by MSGMODE OFF, may be retrieved with the EXTRACT LASTMSG command. See "LASTMSG" on page 234 for details.

The QUIETLY prefix command may be used to override the current MSGMODE setting, and suppress messages (as if MSGMODE was OFF) for the invocation of a single command. See "QUIETLY" on page 164 for details.

## MSTATUS

### Examples

Since this is one of the settings which is saved in the status stack, a useful sequence within a macro is:

```
'PRESERVE'      /* Save current settings in stack      */
'MSGMODE OFF'   /* No messages displayed                               */

:
/* Quietly perform macro functions                    */
'RESTORE'      /* Restore settings, including MSGMODE                */
```

### Return codes

- 0 Operation successful
- 1 Missing keyword
- 2 Keyword truncated
- 3 Keyword unknown

---

## MSTATUS

Opens or closes (toggles) the MStatus window.

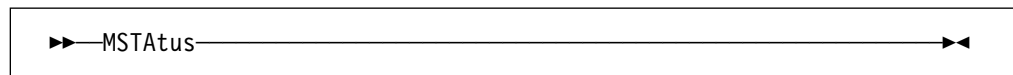

This window displays information about the storage used to contain the extract data information that was loaded with LANGUAGE LOAD commands. This includes:

- number of compile areas
- extract data storage consumption (total, direct, pooled)
- extract data storage pool utilization, including the number of AREAs in the pool which are unused

The MSTATUS command helps when free storage is at a premium.

When extract data file information is removed from storage with LANGUAGE DROP, the storage AREAs that held the extract data are kept for use by later LANGUAGE LOAD commands. The MPACK command returns storage AREAs that no longer hold extract data back to the operating system free storage pool.

### Return codes

- 0 Operation successful

---

## MSTEP

Executes the next target program instruction.

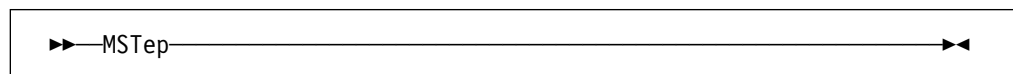

The MSTEP command is different to STEP because the target program is executed *before* control returns to the issuing macro. When STEP is issued from a macro, it has no immediate effect, being processed *after* the macro exits.

After issuing MSTEP, the macro can use EXTRACT EVENT to determine what kind of event occurred in the target program. In general this indicates that a STEP has occurred, but it may also indicate some other condition (for example, a program check).

**CMS** You should ensure that the MSTEP command is issued through the LPSW Fastpath addressing environment, which is the default environment established when the IDF macro is entered. Using this interface eliminates any SVC linkages between REXX and IDF, so that IDF can provide optimum flexibility in what the target program can itself execute under MSTEP. See the usage notes under “MRUN” on page 146 for further details.

1. If you have subroutines within the program which you do not want to single-step through, use the SKIPSTEP command. The SKIPSTEP command causes IDF to skip single stepping when it comes to a subroutine call to a subroutine that was added to the list of subroutines being skipped. For the purposes of single-stepping, the skipped subroutine is treated as one instruction, the subroutine call instruction itself. If a breakpoint or a watchpoint whose condition is true is placed within the execution path of the subroutine being skipped, execution stops at that breakpoint or watchpoint.
2. If the STOPNOP option is OFF or the NOSTOPNP option is ON, then IDF does not stop on NOP and NOPR instructions that follow BAL, BALR, BAS, and BASR instructions.

**CMS**

### Return codes

- 0 Operation successful
- 6 The target program is not yet loaded

---

## NAMES

Display the names of all variables that match a particular pattern and are eligible for display.

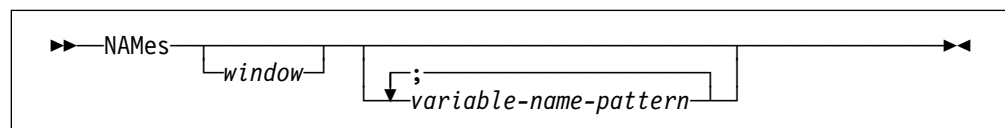

### *window*

An LSM Information window. Select by a Window Specification, or by placing the cursor in the window. If omitted and the cursor is not in an LSM Information window, uses or opens the first LSM Information window.

### *variable-name-pattern*

A variable name matching pattern.

If this parameter is not supplied, then the names of all variables which are eligible for display are shown. Supplied variable name matching patterns define a subset of the eligible names. A variable name is displayed if it matches one variable pattern name.

The variable name matching pattern rules are:

## NEXT

- ? matches a single variable name character
- % matches zero or more variable name characters
- other characters represent themselves
- the search is *not* case sensitive

The variable name information display persists until:

- A NAMES command without arguments is issued
- The window is closed with a CLOSE command.
- Another IDF Language command such as VARIABLE, STRUCTURE, ARRAY, TYPE, CALLERS, PLOCATES, LANGUAGE STATUS, or MAP is issued. These commands update the LSM Information window with new information
- The target program completes execution
- Target program execution progresses beyond the variable's defined scope

### Examples

**If** name lists:

```
301char
ab30xcc
aptr
bptr001
ctra
ctrd
i
ii
mstidx
slvidx
title
```

**Then** NAME would list:

```
aptr
bptr001
```

**and** NAME would list:

```
301char
ab30xcc
```

**and** NAME would list:

```
ctra
ctrd
i
mstidx
slvidx
```

---

## NEXT

Scrolls windows forward.

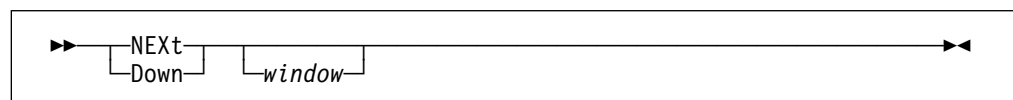

*window*

The window to be scrolled. Select by a Window Specification or by placing the cursor in the window. If omitted and the cursor is not in a scrollable window, then all open scrollable windows are scrolled.

If the HISTORY command was executed, this command has an alternate meaning, see "HISTORY" on page 120 for explanation.

This command works only on a scrollable window, which is any window made smaller with the SIZE command, or an open:

- Break window
- Dump window
- Disassembly window
- LSM Information window
- Options window
- Skipped Subroutines window
- Target Status window

**Return codes**

- 0 Operation successful
- 6 Command issued when it has no meaning

**OFFSET**

Sets or queries the current offset value.

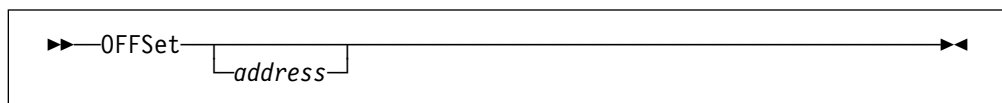

*address*

The new value of the offset.

If not provided, displays the current value of the offset.

The OFFSET option must be ON to obtain a window display that shows dump or disassembly addresses in terms of the offset.

For information about specifying arguments in terms of the offset, see "Address Expressions" on page 73. Arguments may be specified in terms of the offset regardless of the setting of the OFFSET option.

The initial value of the offset is the same as the program's base address (origin in memory).

If an address is provided as part of a command issued by a macro, that address is used in preference to any data typed on the screen.

See also "SET OFFSET" on page 176.

**Return codes**

- 0 Operation successful
- 5 Syntax or other error in expression
- 6 Command issued when it has no meaning

**OPEN**

Opens a Disassembly window, a Dump window, or an LSM Information window.

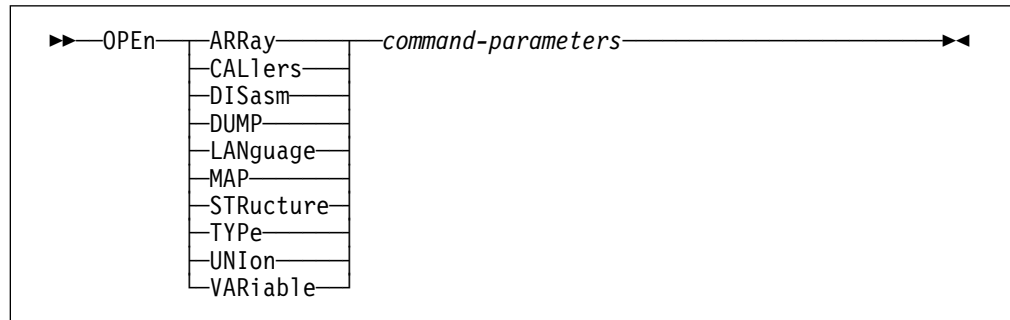

**ARRAY**

Open an LSM Information window with an array element display.

**CALLERS**

Open an LSM Information window with a program call hierarchy display.

**DISASM**

Open a Disassembly window.

**DUMP**

Open a Dump window.

**LANGUAGE**

Open an LSM Information window with a display from a LANGUAGE command.

**MAP**

Open an LSM Information window with a program map display.

**STRUCTURE**

Open an LSM Information window with a structure component display.

**TYPE**

Open an LSM Information window with a variable type attribute display.

**UNION**

Is a synonym for STRUCTURE.

**VARIABLE**

Open an LSM Information window with a variable display.

*command-parameters*

Parameters for the window. The format of this argument depends on the type of the window being opened:

- If a Disassembly window is being opened, the second argument is the address at which the disassembly listing is to begin. For more information on how to specify this address see “DISASM” on page 107.

- If a Dump window is being opened, the second argument is the address at which the storage dump is to begin. For more information on how to specify this address see “DUMP” on page 109.
- If an LSM Information window is being opened for ARRAY, CALLERS, MAP, STRUCTURE, TYPE, or VARIABLE display, the remaining arguments are processed by the command as appropriate to generate the new display.
- If an LSM Information window is being opened for a LANGUAGE command display, the second argument is that needed by the LANGUAGE command. This window is closed if the command does not generate anything to display.

The OPEN command lets you have more than one of these types of window open, letting you view many non-contiguous areas of storage at once.

**Return codes**

- 0 Operation successful
- 1 Window type missing
- 2 Window type too long
- 5 Window type invalid
- 6 Too many windows open

**OPTIONS**

Toggles the display of the options window.

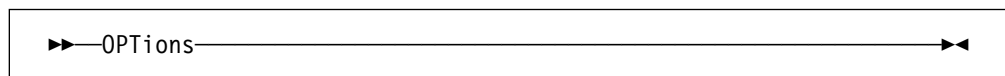

**ORDER**

Moves a window to the top of the screen.

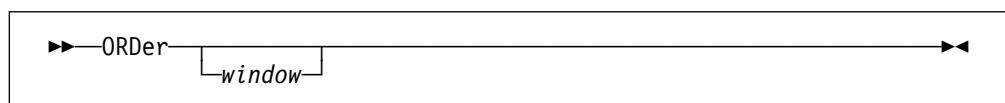

*window*

The window that is moved. Select by a Window Specification or by placing the cursor in the window.

**Return codes**

- 0 Operation successful
- 1 No window selected.

## OREGS

Opens or closes (toggles) the Old Registers window which contains a display of the registers and PSW as they were the last time IDF had control.

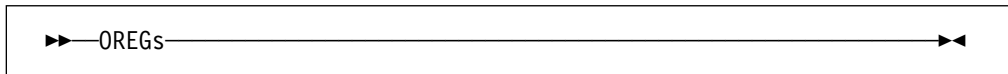

If the CREGS command or the AREGS command was issued, the control registers or the access registers as of the last time IDF was in control are displayed. If the target has not executed any instructions the window is blank.

### Return codes

0 Operation successful

## PACKED

Sets or queries the format in which the data for packed decimal variables are displayed.

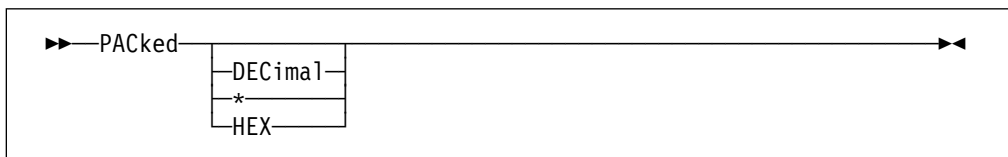

### DECIMAL

Packed decimal variables are displayed in decimal. This is the initial value.

\* The same as DECIMAL.

### HEX

Packed decimal variables are displayed in hexadecimal.

If the display format setting is not specified, the current display format for packed decimal variables is shown in a message.

### Return codes

0 Operation successful  
 2 Keyword truncated  
 5 Not valid packed decimal variable display format

## PARMS

Displays the Parameter List for Callable Blocks.

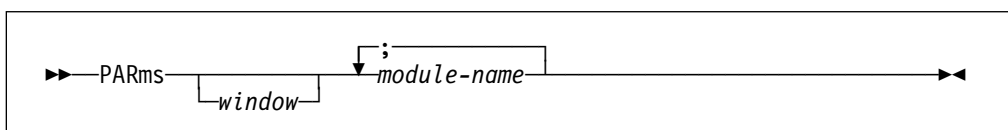

*window*

An LSM Information window. Select by a Window Specification, or by placing the cursor in the window. If omitted and the cursor is not in an LSM Information window, uses or opens the first LSM Information window.

*module-name*

A Callable Block name.

The Parameter List is shown as a list of parameter variable names.

### Return codes

- 0 Operation successful
- 5 Arguments are invalid
- 6 No extract data files containing source code were loaded with LANGUAGE LOAD.

## PAUSE

Delays the execution of IDF (and thereby of the target program).

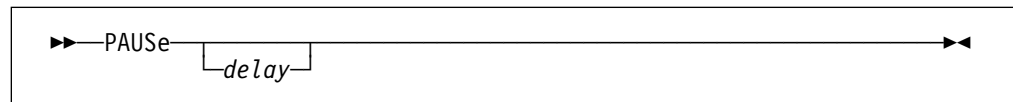

*delay*

The number of hundredths of seconds to pause. An integer from 0 to 99999999. If omitted, a pause of 0.25 seconds is assumed.

### Return codes

- 0 Operation successful

## PER (CMS only)

Enables and disables the exploitation by IDF of Program Event Recorder (PER) functions.

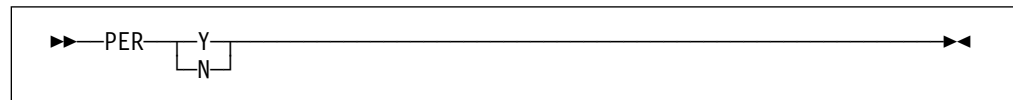

**Y** Enable PER exploitation. Break window displays PER=Y.

**N** Disable PER exploitation. Break window displays PER=N.

### Examples

```
SET PER Y
SET PER N
```

## PFK

Assigns a command or macro invocation to a PF key.

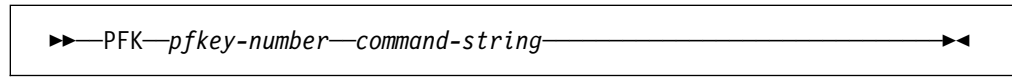

*pfkey-number*

An integer identifying the PF key. Has a value from 0 to 24. 0 is the ENTER key.

*command-string*

The PF key command text. This has a maximum of 40 characters.

### Examples

```
PFK 1 SUBSET
PFK 10 ADSTOP
PFK 0 MACRO MYENTER
```

When you press the PF key, the command that you entered against the key is executed. Parameters typed on the command line may be used as parameters for the command.

If you want a PF key to invoke a macro, you must use the MACRO command in the text assigned to the PF key.

## PFKDISP

Adjusts the display of PF key settings at the bottom of the screen in the Command window.

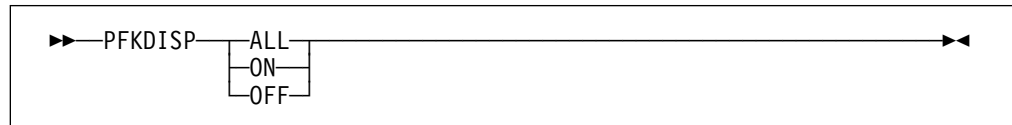

**ALL**

Display settings of PF keys 1 to 24.

**OFF**

Display no PF key settings.

**ON**

Display settings of PF keys 1 to 12.

The size of the Command window varies depending on the number of PF key settings displayed.

## PLOCATES

Displays the variables that may be located with a given locator (pointer) variable.

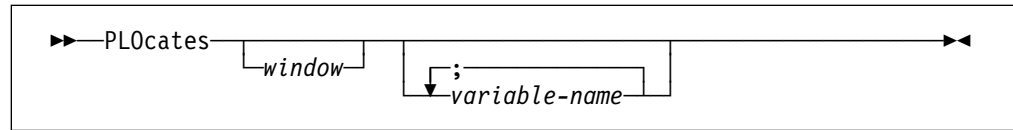

The PLOCATES command determines the variables which may be located with a given locator (pointer) variable, and displays an entry for each in the LSM Information window.

### *window*

An LSM Information window. Select by a Window Specification, or by placing the cursor in the window. If omitted and the cursor is not in a LSM Information window, uses or opens the first LSM Information window.

### *variable-name*

A variable name.

Only the variable name is relevant in determining the located variables. Extra information such as:

- Locating expressions for based variables
- array index values
- substring ranges

is not needed, and should *not* be specified.

The Pointer Locates information display persists until:

- A PLOCATES command without arguments is issued.
- The window is closed with a CLOSE command.
- Another IDF Language command such as VARIABLE, STRUCTURE, ARRAY, TYPE, CALLERS, LANGUAGE STATUS, or MAP is issued. These commands update the LSM Information window with new information.
- The target program completes execution.
- Target program execution progresses beyond the variable's defined scope.

### Examples

```
ploc base@
ploc DSA_ptr
plocates ptr1;ptr2
```

## PRESERVE

Saves the current value of the IDF settings in a 32 element stack.

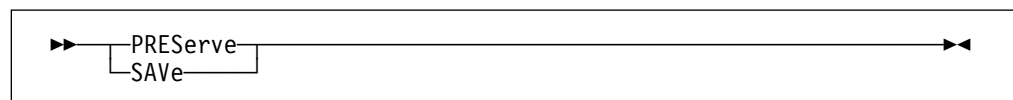



**Return codes**

- 0 Operation successful
- 6 Command issued when it has no meaning

**PROGCHK (CMS only)**

Simulates a program check to the target program, typically to test the target program's recovery from program checks (for example, through an established ESPIE or ESTAE or ABNEXIT or PSW steal).

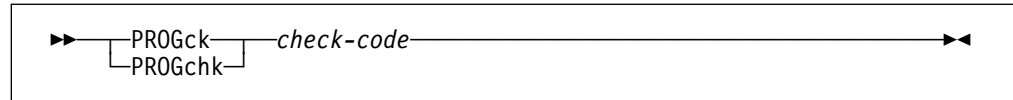
*check-code*

The program check code to be simulated. An integer, with the following possible values:

- 1 Operation exception
- 2 Privileged operation exception
- 3 Execute exception
- 4 Protection exception
- 5 Addressing exception
- 6 Specification Exception
- 7 Data exception
- 8 Fixed-point overflow exception
- 9 Fixed-point divide exception
- 10 Decimal overflow exception
- 11 Decimal divide exception
- 12 Exponent overflow exception
- 13 Exponent underflow exception
- 14 Significance exception
- 15 Floating-point divide exception

These values are as defined by the S/390™ hardware.

The program check is simulated with the current GPRs, FPRs, ARs, CREGS, and PSW.

As this command is intended to simulate an error and drive an error handler, that handler may be expecting some other conditions that must be set up before this command is issued. If necessary, you must first change these values before issuing the PROGCK command.

**Return codes**

- 0 Operation successful

## PROGCK

The PROGCK command is a synonym of PROGCHK. For details, see “PROGCHK (CMS only)” on page 161.

## PSW

The PSW command is a synonym of the GOTO command. For details, see “GOTO” on page 117.

## PSWSTEAL (CMS only)

Declares a target program instruction that steals the SVC or PGM new PSW.

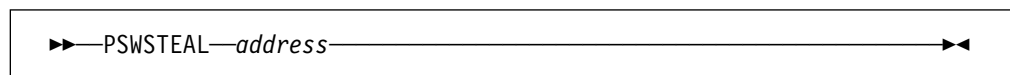

### *address*

The storage location. If an expression is present on the command line, that expression is used as the argument. If the command line is empty, an attempt is made to determine the address from the cursor position.

The PSWSTEAL command effectively sets a permanent breakpoint at the specified location. Whenever that instruction is executed, IDF performs an interpretive execution of the instruction. It appears to the target program that it has stolen the new PSW. However, IDF retains control of the PSW locations.

To guarantee correct results, you must declare all occurrences of the following:

- All references (both store and fetch) to either SVC or PGM New.
- All store references to SVC or PGM Old.
- All store references to locations 136-159 (interrupt information)

The following instructions are supported for interpretive execution through the PSWSTEAL command, and are therefore its only valid targets:

**MVC** move characters  
**STM** store multiple  
**LM** load multiple  
**ST** store  
**L** load

The maximum number of PSWSTEAL breakpoints that may be active at any time is 75. These are not shown on the Break window, but may be obtained by means of the EXTRACT BREAK command.

If the PSWSTEAL command is issued against an instruction that is already declared, the PSWSTEAL breakpoint is cleared. The PSWSTEAL command toggles these special breakpoints.

A normal breakpoint may be set at the same instruction location as a PSWSTEAL breakpoint. When execution reaches the normal breakpoint, you are notified as usual. When execution passes through the PSWSTEAL breakpoint, no notification

is performed, just as no notification is performed if the instruction is executed normally. Once set, the PSWSTEAL breakpoints may be forgotten.

Instructions which are the target of PSWSTEAL commands must reside in read/write storage.

When you issue the PSWSTEAL command, IDF exploitation of PER is locked out for the remainder of the debugging session. This does not affect the program in terms of its ability to use PER.

When the new PSW locations in low storage are displayed on a Dump window, the values the program placed in them are visible. However if you use EXTRACT LOCATION to obtain this information, IDF's PSWs are returned.

This facility enables you to use IDF to single-step through every instruction of the program's first level interrupt handler.

As a matter of convenience, the following is suggested:

- Define all instructions in the program that must be declared with PSWSTEAL as external symbols with a common prefix, for example PSWnnnn
- Insert code in the PROFILE macro to read the program's MAP file, locate the external symbols, and set the PSWSTEAL breakpoints. For example:

```

/*-----*/
/* Read pgm MAP file into MAPREC.n array          */
/*-----*/
fid = pgm 'MAP *'
Address Command 'EXECIO * DISKR' fid '(FINIS STEM MAPREC.'
If rc ^= 0 Then
  Do
    'SET MSG2 Return code' rc 'trying to read 'fid''
    'SET ALARM'
  Exit
End

/*-----*/
/* Establish PSWSTEALS using information from MAP file */
/*-----*/
PSWsteals = 0
Do i = 1 To maprec.0
  Parse Upper Var maprec.i label .
  If Substr(label,1,3) ^= 'PSW' Then Iterate
  'PSWSTEAL' label
  If RC ^= 0 Then
    Do
      'SET MSG2 Error on PSWSTEAL' label' after' ,
        PSWsteals 'successful, RC='RC
      'SET ALARM'
    Exit
  End
  PSWsteals = PSWsteals + 1
End

```

This makes the fact that you are stealing PSWs transparent as far as your operational procedures are concerned.

## QUALIFY

### Return codes

- 0 Operation successful
- 1 No address specified
- 5 Syntax or other error in expression, or unsupported instruction
- 6 Module not yet loaded, or maximum number of PSWSTEAL already set

---

## QUALIFY

Sets the name of the module that is used with some commands and addresses when no explicit module name is supplied.

►►—QUALIFY—*default-module-name*—————►►

*default-module-name*

The name of the new default module.

### Examples

SET QUALIFY ASMLANGX

---

## QQUIT

The QQUIT command is a synonym of the QUIT command. For details, see “QUIT” on page 165.

---

## QUIET

Controls the display of informational messages.

►►—QUIET—  
    ON  
    OFF—————►►

### ON

Informational messages are displayed.

### OFF

Informational messages are not displayed.

---

## QUIETLY

Temporarily suppresses the display of I (Informational), W (Warning) and E (Error) messages during the execution of the specified command.

►►—QUIETLY—*command-name*—*command-parameters*—————►►

*command-name*

The command that is being executed.

*command-parameters*

The parameters needed by this command.

The QUIETLY prefix command overrides the current MSGMODE setting, and suppresses messages (as if MSGMODE was OFF). It does not affect the actual value of the MSGMODE setting.

See “MSGMODE” on page 149 for more details about message suppression.

If an IDF message that normally rings the terminal alarm is issued under QUIETLY, the alarm is also suppressed.

**Return codes**

- 0 Operation successful
- 1 No command specified
- 2 Command name truncated
- 3 Command unknown
- Other
- Return code from the command

**QUIT**

Quits IDF.

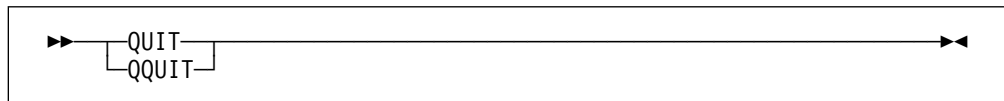

If the QUIT command is issued from a PF key, it must be issued twice (press the key twice) to quit.

If the QUIT command is issued from the command line through a PF key that is set to COMMAND, IDF exits immediately.

If the QUIT command is issued by a macro, it must be issued twice to make IDF exit. In this case, IDF does not exit until the macro stops.

**Return codes**

- 0 Operation successful

**RCQUIT**

Quits IDF with a specific return code.

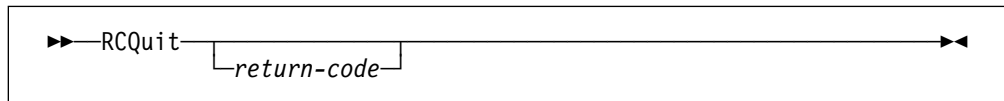
*return-code*

The return code. This must be a valid IDF expression. If omitted, the command line is checked for an expression and if a valid expression is found

## REFRESH

its value is used as the return code. If omitted and the command line is empty, the current content of the target program's R15 is used as the return code.

Intended for use by macros, but can also be issued from the command line if desired.

### Return codes

If an invalid expression is provided, either as part of the command or on the command line, RC=5 is returned to the invoking macro and processing is ended.

If the RCQUIT command completes successfully, a return code of 0 is passed to the issuing macro. When the macro exits, IDF returns to CMS, TSO or VSE and passes the specified return code.

---

## REFRESH

Forces IDF to rebuild the IDF user interface screen image, and optionally rewrite it to the terminal.

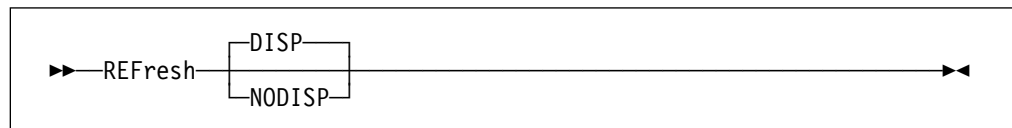

### DISP

Rebuilds the screen image, and writes it to the terminal.

This is useful if a macro wishes to update the IDF user interface display, but continue running. Normally the rebuild and screen update does not occur until the macro completes execution.

### NODISP

Rebuilds the screen image, but does not write the updated image to the terminal.

This is useful if a macro has issued a command which causes an update of the IDF user interface display, and needs to issue EXTRACT commands for the new display image. Eliminating the extra terminal update speeds up the execution of the macro.

This facility can even be used to hide the update by immediately issuing more commands to restore the user interface display to the previous configuration.

The REFRESH command can also be used to restore the IDF user interface display. This is usually only needed in a macro that sends line mode output to the screen, and should only be needed on TSO.

### Return codes

0 Operation successful

---

## REGS

Opens or closes (toggles) the Current Registers window which contains a display of the registers and PSW or the current contents of the control registers or the access registers.

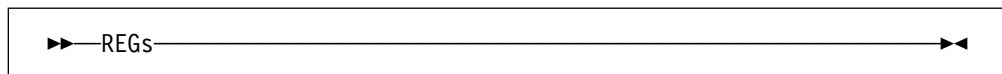

### Return codes

0 Operation successful

---

## REGSTOPS (CMS only)

The REGSTOPS command is a synonym of the ADSTOPS command. For details, see “ADSTOPS (CMS only)” on page 89.

---

## RESTORE

Restores the IDF settings from the 32 element stack.

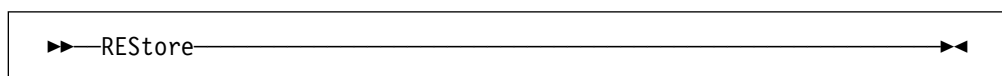

If the IDF settings stack is empty, the current setting values are maintained.

This command is intended for use within IDF macros, as it lets you restore the IDF settings to the state that they held when the last PRESERVE or SAVE command was issued.

### Return codes

0 Operation successful

---

## RETRIEVE

Places the previous command on the command line.

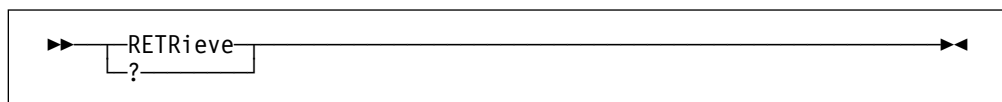

IDF maintains the last 30 inputs in a circular buffer. The RETRIEVE function shifts the most recent of these into the command line.

### Return codes

0 Operation successful

## RIGHT

---

## RIGHT

Scrolls a window to the right.

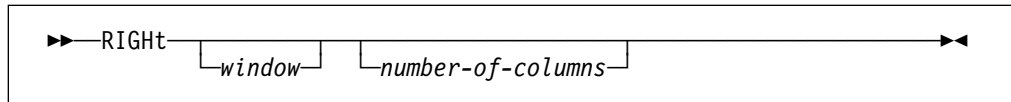

### *window*

A scrollable window. Select by a Window Specification or by placing the cursor in the window. If omitted and the cursor is not in a scrollable window, then all open scrollable windows are scrolled.

### *number-of-columns*

The number of columns by which the window is scrolled.

This can be specified as:

- an integer
- an integer prefixed by a +
- an integer prefixed by a –, specifying the number of screen columns by which the window is to be scrolled to the *left*.

If this parameter is omitted, each window being scrolled is scrolled by the current number of data columns for that window.

This command is usually only meaningful when a Disassembly window is open. However, any window made smaller with the SIZE command can also be scrolled.

### **Return codes**

- 0 Operation successful
- 5 Arguments are invalid
- 6 Command issued when it has no meaning

---

## RLOG

The RLOG command (Repeat from Log) controls the execution of IDF commands stored in the command log.

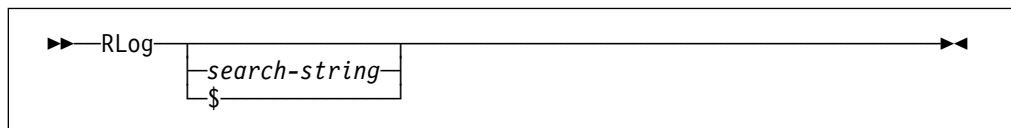

### *search-string*

The text of a search string. All commands in the log file, up to and including the first command which begins with the specified search argument, are executed. This search is case insensitive.

By providing an argument not in the log file, for example eof, you can execute all commands in the log.

\$ RLOG first executes anything on the command line, then retrieves the next command from the log and places it on the command line. Thus by repeatedly pressing the PF key, you can step through as many commands as you like, previewing (and optionally modifying) them before they are executed.

When issued with no arguments, the next command is retrieved from the log file and placed on the command line. You can then press ENTER to execute it, or clear the command line as you choose. By clearing the command line, you skip executing the command.

You can get a similar result by specifying the RLOG option at invocation. When specified at invocation, RLOG means:

1. Repeat all commands in the log, and
2. Start logging any new commands issued.

If you are executing many commands from the log file, any command which has a nonzero return code or sets the alarm, stops the RLOG operation.

For more details on command logging support, see “Command Record and Playback Features” on page 72.

## RUN

Begins execution of the target program and runs to the next unusual event (such as a breakpoint, program check, or completion).

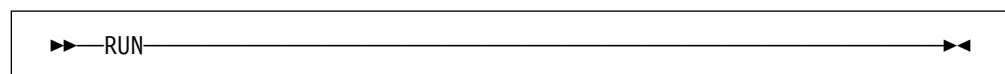

If the RUN command is issued by a macro, it does not take effect until the macro exits.

The MRUN command performs a similar function. It executes target instructions *before* returning control to the invoking macro.

### Return codes

0 Operation successful

## RUNEXIT

Executes the exit routine, passing it the single argument PFKEY.

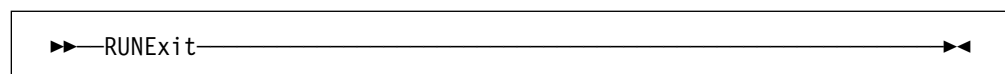

For more information, see Chapter 13, “The IDF Exit Routine” on page 214.

**Return codes**

- 0 Exit routine executed
- 6 Exit routine not found

**R0-R15**

Evaluates the expression provided and places it in the indicated General Purpose Register.

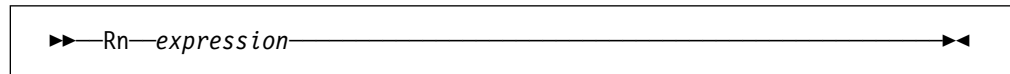
*expression*

The expression to be evaluated. Can also be set from the cursor position.

There are 16 separate commands, named R0, R1, ... R15. They all have the same arguments and function, and differ only in which GPR is changed.

**Return codes**

- 0 Operation successful
- 1 No address specified
- 5 Syntax or other error in expression
- 6 Conditions do not permit completion of command

**SALIMIT**

Sets the maximum depth of the CALLERS display.

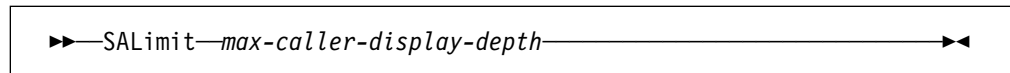
*max-caller-display-depth*

The maximum depth of the CALLERS display. Integer from 1 to 999999.

The initial value is 100.

This is intended to prevent problems when the program call chain is damaged, or is of unexpected depth (due to runaway recursion).

**Return codes**

- 0 Operation successful
- 1 Missing keyword
- 2 Keyword truncated
- 3 Keyword unknown
- 5 Arguments are invalid

---

## SAREGS

Toggles the display of Save Area header and register information when the CALLERS command is displaying information about each generation of the program caller hierarchy.

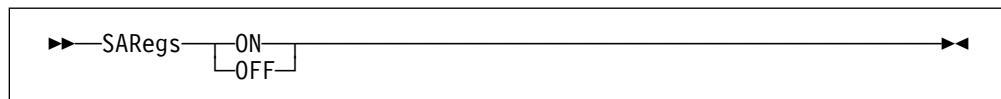
**ON**

Enable the display of the Save Area header and registers.

**OFF**

Disable the display of the Save Area header and registers.

**Return codes**

- 0 Operation successful
- 1 Missing keyword
- 2 Keyword truncated
- 3 Keyword unknown

---

## SAVE

The SAVE command is a synonym of the PRESERVE command. For details see “PRESERVE” on page 159.

---

## SEARCH

Searches for a string in storage.

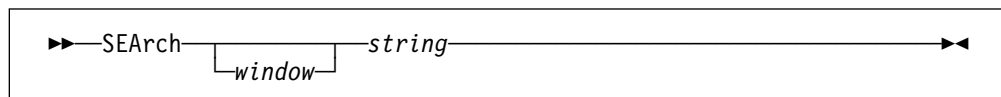
*window*

A Dump window or Disassembly window. Select by a Window Specification or by placing the cursor in the window. If omitted, the search begins at the first location that is displayed. If both a Dump window and a Disassembly window are open, but show different storage areas, it is not clear where the search should begin, and an error message is issued.

*string*

The string for which IDF is to search.

Search arguments may be specified in either hexadecimal or character form. Hexadecimal search arguments must contain an even number of hex digits. An apostrophe in a character argument is represented by two successive apostrophes.

Examples of valid search arguments are:

## SELFNUCX (CMS only)

```
X'0741fe3022'  
C'The quick brown fox'  
C'The dog''s feet are'
```

This function is only valid when a Dump window or a Disassembly window is open.

When the search argument is located, it becomes the first location displayed in the selected window or in the first Disassembly window or Dump window.

Repeat the command to continue searching the remainder of virtual storage.

If the search argument is not found within the target program, a message is issued.

### Return codes

- 0 Operation successful
- 5 Search argument missing or invalid
- 6 Not valid in current display mode, unable to determine start address for search, or target not found

---

## SELFNUCX (CMS only)

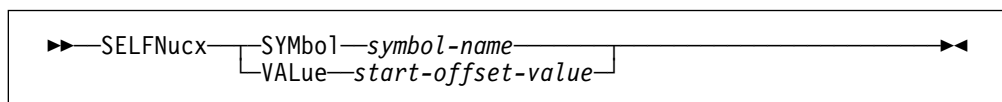

Lets the PROFILE macro control the start offset of the code that is relocated by a self-loading CMS Nucleus extension.

### *symbol-name*

A symbol that defines the start of the relocated code.

### *start-offset-value*

An expression that resolves to the start offset value.

This only applies to the target program specified when IDF was invoked.

SELFNUCX SYMBOL may only be issued within the PROFILE macro before the target program is loaded into memory. If it is issued after that point, RC=6 results.

SELFNUCX VALUE may be issued within the PROFILE macro, and may also be used later to let you (or IDF macros) redefine this offset after the target program is loaded.

When debugging a self-loading nucleus extension, it should be possible to invoke IDF to debug the program as a standard user-area or transient module, and trace through the self-loading code. After the code is relocated, use the BASE and SELFNUCX VALUE commands to follow the relocated code to its new location. Symbol resolution is automatic, determined by the program base address, symbol value, and SELFNUCX offset.

**Examples**

```
SELFNUCX SYMBOL FREEGO
SELFNUCX VALUE X'44'
```

**SET ADSTOP (CMS only)**

Sets or clears one end of an ADSTOP range.

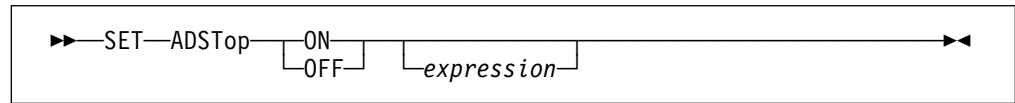
**ON**

Set one end of an ADSTOP range.

**OFF**

Clear one end of an ADSTOP range.

*expression*

An expression resolving to the address for the end of the ADSTOP range.

See also “ADSTOPS (CMS only)” on page 89.

**Examples**

```
SET ADSTOP ON ALLOPEN+4
SET ADSTOP OFF X'200E4'
```

**SET AREG**

Changes the contents of an Access Register (AR).

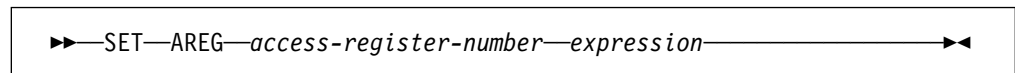
*access-register-number*

The Access Register number; an integer from 0 to 15.

*expression*

The new value for the Access Register.

You must be in an ESA environment for this command to work.

**Examples**

```
SET AREG 2 X'00010004'
```

**SET BREAK**

Sets or clears a breakpoint at an address.

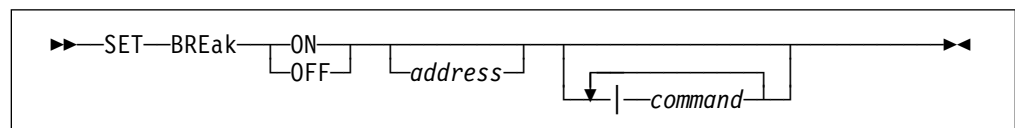

## SET COMMAND

### ON

Set the breakpoint.

### OFF

Clear the breakpoint.

### *address*

The address at which the breakpoint is set. If an expression, the expression is used to provide the address.

If omitted, the address is determined from the cursor position. If it is not possible to determine an address from the cursor position (for example when the cursor is on the command line and the command line is empty), then an error.

### *command*

A command that is executed when the breakpoint is taken, before control is returned to the user. Many commands can be specified at the end of the SET BREAK command, separated from the address and each other by a vertical bar (|). If a command receives a non-zero return code, the remaining commands in the list are not executed.

See also "BREAK" on page 95.

### Examples

```
SET BREAK ON ALLOPEN+8
```

```
SET BREAK OFF 4(R2)
```

```
SET BREAK ON MOON SET MSG Houston... the Eagle has landed.
```

---

## SET COMMAND

Places text on the command line.

```
▶▶ SET COMmand text ▶▶
```

### *text*

The text to be placed on the command line.

### Examples

```
SET COMMAND Press VALUE to see it yell about this expression
```

---

## SET EXITEXEC

Names the current IDF exit routine (exec).

```
▶▶ SET EXItexec EXIT  
IDF-exit-exec ▶▶
```

### EXIT

Default name of IDF exit routine.

*IDF-exit\_exec*

The name of the current IDF exit routine.

For more information, see Chapter 13, “The IDF Exit Routine” on page 214.

### Examples

```
SET EXITEXEC STUFF
```

---

## SET GLOBAL STEM

Writes the data in the specified REXX stemmed arrays to the same named Global Storage stems.

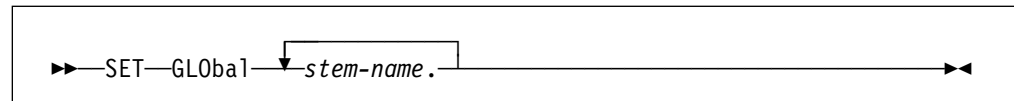

*stem-name.*

A REXX stemmed array name. Must have a terminating period.

Each REXX stemmed array must be in standard EXECIO READ/WRITE stem format.

Any existing Global Storage stem by the same name is dropped before the REXX stemmed array is inspected.

If the *stemname.0* item is not a positive integer, an error message is issued. The new Global Storage stem is *not* created.

If a REXX stemmed array element is omitted, an error message is issued. The new Global Storage stem is *not* created.

REXX stemmed array elements with null values are supported.

If a REXX stemmed array element is longer than 4,096 bytes, an error message is issued. The new Global Storage stem is *not* created.

### Examples

```
SET GLOBAL ptr-array.
```

```
SET GLOBAL data.buf1.stem.
```

### REXX Variables Read

*stemname.0*

Number of items in the stemmed array

*stemname.n*

Information for the stemmed array element

---

### SET GLOBAL TEXT

Saves the value of the IDF global area. Other macros can then access it, by using the EXTRACT GLOBAL command.

```
▶▶ SET GLOBAL global-text ▶▶
```

*global-text*

The new global text value, up eighty characters in length.

Do not end the first blank-delimited word of the new global text value with a period (.), as this is a SET GLOBAL STEM command.

#### Examples

```
SET GLOBAL state3
```

---

### SET ICOUNT

Sets the count of instructions executed to a specified value.

```
▶▶ SET ICOUNT instruction-count ▶▶
```

*instruction-count*

An expression which is resolved to the new instruction count value.

Valid only when the PATH option is set.

#### Examples

```
SET ICOUNT 0
```

---

### SET OFFSET

Toggles the display of addresses using offsets.

```
▶▶ SET OFFSET  ON  OFF ▶▶
```

#### ON

Enables the display of addresses using offsets.

#### OFF

Disables the display of addresses using offsets.

## SET OPTION

Sets an IDF option ON or OFF.

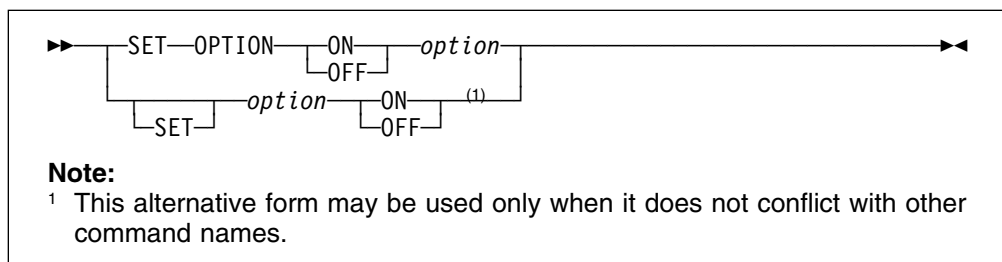

### *option*

The IDF option name.

The IDF options control the environment of IDF, which in turn controls the way IDF works, and the information you see on the screen.

Most options can be controlled through the SET OPTION command. Many of these options can also be specified at the invocation of IDF, either as parameters to the ASMIDF call, or as items in the PROFILE macro.

Some options are invocation options only, and cannot be controlled after invocation with the SET OPTION command. The information provided by these options must be available at invocation. It makes no sense for it to be provided later.

Some options are controlled by a command of the same name. Some of these can also be specified at invocation.

These options can be specified at invocation and set by the SET OPTION command:

1ADSTOP	EXITEXEC	NOAUTOSZ	OFFSET	SCDACTIV
AMODE24	FULLQUAL	NOBCX	OLDBREAK	SELFNUCX
AMODE31	HEXDISP	NODSECTS	PASSPGM	STOPNOP
ASCII	HEXINPUT	NOIMPMAC	PATH	STOPSTMT
AUTOLOAD	IMPMACRO	NOINVPSW	PATHFILE	SVC97
AUTOSIZE	INVPSW	NOMODMAP	QWDUMP	SWAP
BCX	LSMDEBUG	NOSTOPNP	RISK	SYSTEM
CKSUBCM	MACROLOG	NOSTOPST	RLOG	TRACEALL
CMDLOG	MODMAP	NOSVC97	ROWSTYLE	TRANS
CMPEXIT	NOAUTOLD	NUCEXT	SBORDER	UNFTDUMP
DMS0				

These options are set and changed by a command with the same name. They cannot be specified as an invocation parameter, but each option has an initial value:

APROGMSG	BRIEF	MAJOR	MSGMODE	SPACE
AUDIT	COMPACT	MSGID	SAREGS	

These options are set by a command with the same name, and can be specified as an invocation parameter:

COLORS	COLOURS	MODE
--------	---------	------

## SET PSW

These options are specified only as an invocation option. They cannot be changed by a command, or by the SET OPTION command:

FASTPATH	LIBE	LUNAME	PROFILE
ISA	LINE	NOPROFIL	RLOG

For explanations of options specified at invocation, see “IDF Invocation” on page 19.

For explanations of options specified by a command, see the command description.

The current state of many options is displayed in the Options window, see “Options window” on page 68.

You can use the alternate syntax of *option* ON or SET *option* ON when the option name does not conflict with any other command or SET command name. If the option name conflicts with a command name, the alternate syntax SET option ON may still be used.

### Examples

```
hexinput ON
SET offset ON
SET OPTION ON impmacro
```

---

## SET PSW

Sets the current PSW.

```
▶▶—SET—PSW—hex————▶▶
```

*hex*

The new PSW value, expressed as 1 to 16 hexadecimal digits.

Normally the SET PSW command does not let you set the PSW to an invalid PSW. If the INVPSW option is ON, then the PSW may be set to any combination of sixteen hexadecimal digits. This is useful in writing a macro that gets control at a breakpoint in an error recovery routine and you want the PSW to show the original PSW in error.

Normally it does not let you set the address part of the PSW to an address that is outside the programs limits. If the TRACEALL option is on, the address part of the PSW may be set to any even address from zero to VMSIZE. If the RISK option is on, the address part of the PSW may be set to any even address you want.

### Examples

```
SET PSW FFE0000000020000
```

---

## SET REGSTOP (CMS only)

Controls PER monitoring of General Purpose Register (GPR) contents.

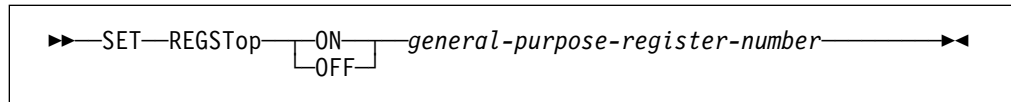
**ON**

Enable PER monitoring of the contents of the specified GPR.

**OFF**

Disable PER monitoring of the contents of the specified GPR.

*general-purpose-register-number*

The GPR number; an integer from 0 to 15.

See also “ADSTOPS (CMS only)” on page 89.

**Examples**

```

SET REGSTOP ON 4
SET REGSTOP ON 12
SET REGSTOP OFF 9
  
```

---

## SET SIZE

Specifies the size in bytes of the target program specified when IDF was invoked.

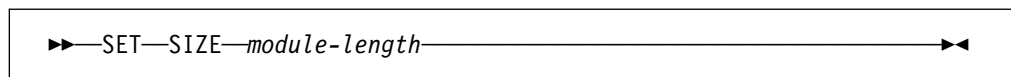

*module-length*

An expression which resolves to the module length value.

IDF automatically sets the size based on information found in the module file. Use this command to override the size determined by IDF.

Use the MODULE SIZE command to specify the size in bytes of other programs defined to IDF.

**Examples**

```

SET SIZE X'1A08'
  
```

---

## SHOW

Controls the display of source code and disassembly. It is used to enable the display of specific information, and is the opposite of the HIDE command.

# SHOW

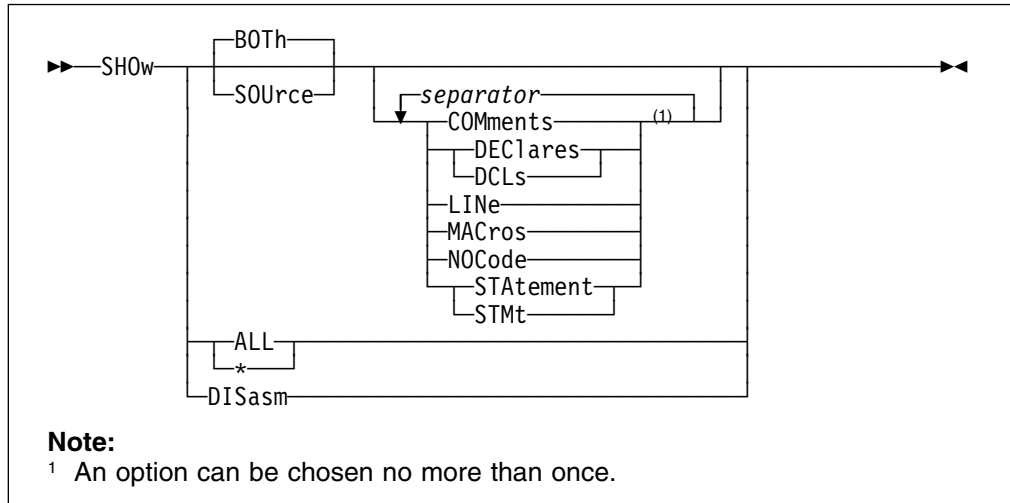

## **BOTH**

Show source code interspersed with the generated assembler.

## **SOURCE**

Show source code only, without interspersed assembler code.

## **SEPARATOR**

A comma, blank or semicolon. Separates the suboptions of SOURCE and BOTH.

## **COMMENTS**

Show block comment source when source code is displayed.

## **DECLARES | DCLS**

Show declaration source when source code is displayed.

## **LINE**

Show source line numbers when source code is displayed.

## **MACROS**

Show macro expansion source when source code is displayed.

## **NOCODE**

Show source lines with no corresponding object code when source code is displayed.

## **STATEMENT | STMT**

Show source statement numbers when source code is displayed.

## **ALL | \***

Show all source code, interspersed with the generated assembler.

## **DISASM**

Show disassembled assembler code only, without source code.

The initial settings are:

- BOTH, COMMENTS, DECLARES, MACROS, NOCODE, STATEMENT

**Return codes**

- 0 Operation successful
- 2 Keyword truncated
- 5 Invalid information type keyword

**SIZE**

Changes the size of a window on the screen.

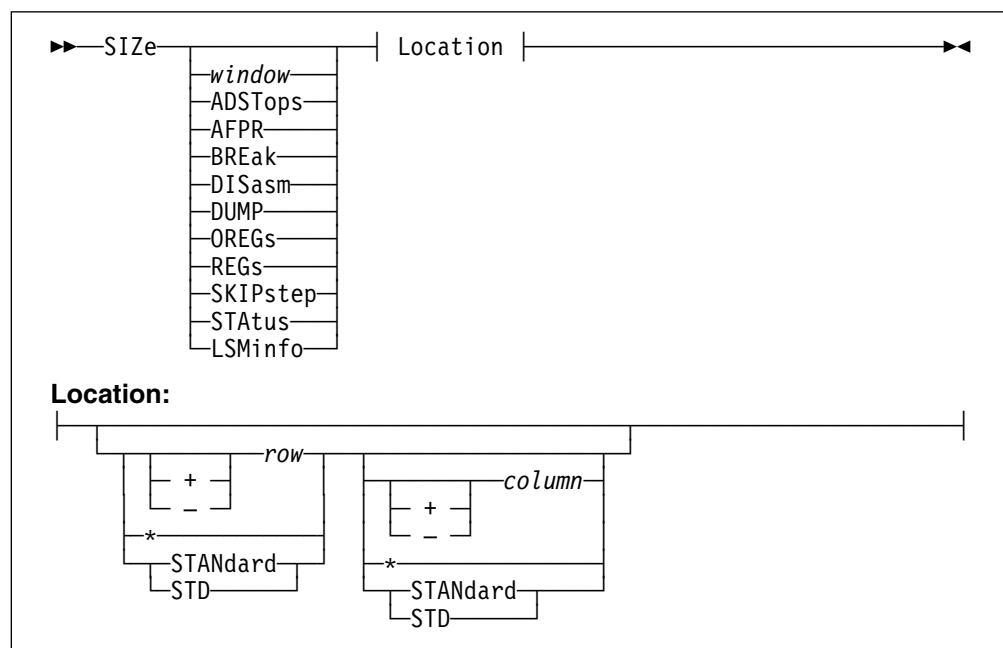
**WINDOW**

The window to be sized. Select by a Window Specification, or by placing the cursor in the window.

**ADSTOPS**

The AdStops window.

**AFPR**

The Additional Floating-Point Registers window.

**BREAK**

The Break window.

**DISASM**

The Disassembly window with the lowest window id.

**DUMP**

The Dump window with the lowest window id.

**OREGS**

The Old Registers window.

**REGS**

The Current Registers window.

### **SKIPSTEP**

The Skipped Subroutines window.

### **STATUS**

The Target Status window.

### **LSMINFO**

The LSM Information window with the lowest window id.

#### *rows*

The number of window data rows to be displayed.

This may be specified as:

- an integer. Specifies an absolute number of window data rows.
- An integer prefixed by a +. Specifies the number of extra window data rows to be used.
- An integer prefixed by a -. Specifies the number of fewer window data rows to be used.
- \* Indicates that the current number of data rows for this window should be used.
- STANdard | STD. Indicates that the standard number of data rows for this window type should be used.

If this parameter is omitted, the position of the cursor on the screen is used as the new location of the lower right corner of the window. In this case, the columns parameter must also be omitted.

#### *columns*

The number of window data columns to be displayed.

This may be specified as:

- An integer. Specifies an absolute number of window data columns.
- An integer prefixed by a +. Specifies the number of extra window data columns.
- An integer prefixed by a -. Specifies the number of fewer window data columns.
- \* Indicates that the current number of data columns for this window should be used.
- STANdard | STD. Indicates that the standard number of data columns for this window type should be used.

If this parameter is omitted, the number of data columns in the window remains the same.

If the window is not named, it is assumed that this command is specifying the number of rows in a newly sized window.

Windows cannot be made larger than their maximum size. You can size them so that they overlap any other window. However, no window can overlap the Command window. You cannot size a window so that some of the window falls outside the screen. If you try, IDF repositions the window so that it remains completely on the screen.

If a window is closed and then opened, its size is the system default for that type of window and not that specified on the last SIZE command for that window type.

### Examples

To change the window 01 to have 5 data rows and 60 data columns:

```
SIZE =01 5 60
```

To change the window in which the cursor is placed to have 8 data rows and 20 data columns:

```
SIZE 8 20
```

To add 2 data rows to the window in which the cursor is placed:

```
SIZE +2
```

To resize window 03 so that the lower right corner is at the current cursor position:

```
SIZE =03
```

### Return codes

- 0 Operation successful
- 1 Window name or Row location missing
- 2 Operand longer than eight characters
- 5 Window name invalid or syntax or other error in expression

---

## SKIPSTEP

Sets or clears a subroutine to be skipped, or displays the Skipped Subroutines window.

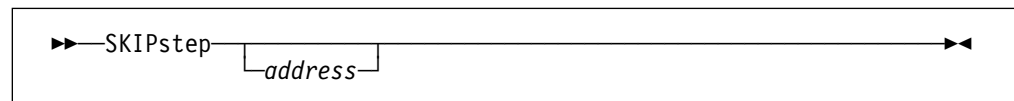

### *address*

A storage location.

If an expression is present on the command line, that expression is used as the argument. If the command line does not contain an expression, an attempt is made to determine the address from the cursor position.

If no expression is provided on the command line, and it is not possible to determine an address from the cursor position (for example when the cursor is on the command line and the command line is empty), the Skipped Subroutines window is opened if it is not already open. If the Skipped Subroutines window is already open, it is closed.

If an address is supplied, either as an expression on the command line or by means of cursor position, the subroutine at that address is skipped when the instruction that calls it is single-stepped, statement stepped, or executed when the PATH or FASTPATH options are on. If the subroutine at the specified address is already being skipped, it is removed from the list of skipped subroutines. The SKIPSTEP command acts as a toggle to set or clear a skipped subroutine.

## SPACE

If a breakpoint or a watchpoint whose condition is true is placed within the execution path of the subroutine to be skipped, execution stops at that breakpoint or watchpoint.

### Return codes

- 0 Operation successful
- 1 No address specified
- 5 Syntax or other error in expression
- 6 Location, or location does not contain a valid instruction

---

## SPACE

Separates the display of variables or sets of components with a blank line.

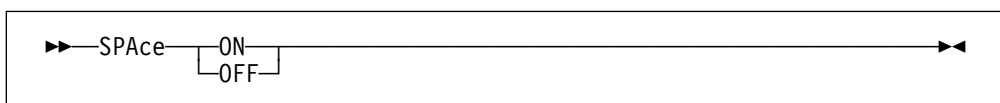

### ON

Enable the display of the blank separator line.

### OFF

Disable the display of the blank separator line.

When many variables or structure components are displayed, IDF normally begins the display of each variable or set of components immediately. This command can separate each variable or set of components with a blank line.

### Return codes

- 0 Operation successful
- 1 Missing keyword
- 2 Keyword truncated
- 3 Keyword unknown

---

## STATUS

Opens and closes (toggles) the Target Status window that contains information about the target programs.

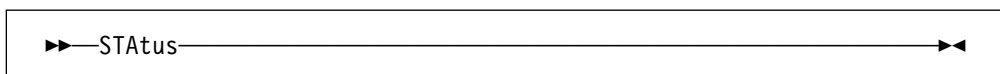

For each target program, this includes:

- the target program name
- the target program start location
- the target program length (bytes)
- the target program primary entrypoint location.
- the number of internal assembler level (TEST-format) symbols known to IDF

Information about the initial target program is shown when the Target Status window is opened. If many target programs are loaded, the PREVIOUS or NEXT

commands may be used to scroll the Target Status window to view the information for the extra programs.

The target program name are highlighted when the information for the qualified program is shown.

### Return codes

0 Operation successful

## STEP

Executes the next instruction in the target program.

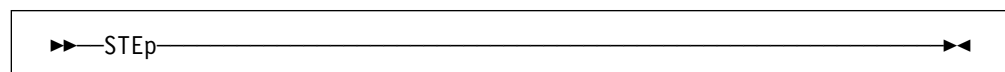

If the STOPNOP option is OFF or the NOSTOPNP option is ON, then IDF does not stop on NOP and NOPR instructions that follow BAL, BALR, BAS, and BASR instructions.

Step works by establishing a breakpoint at the next instruction which is immediately reset once reached. If an Execute instruction has the immediately following instruction as its target, then single-stepping from the EX will fail (see “BREAK” on page 95 for information on how breakpoints are established).

For more details see “Controlling Single-stepping your Program” on page 79

### Return codes

0 Next instruction is executed when macro exits

6 Single-step mode locked out pending execution of startup command

## STMTSTEP

Performs a repeated single-step operation until the target program is executing a source statement other than the one it was executing when the command was issued.

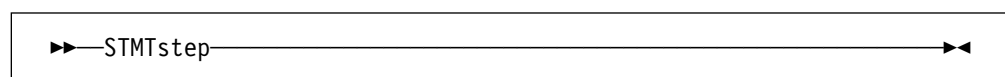

If a significant event occurs during the execution of the STMTSTEP command, execution stops at that point. Examples of significant events are cases where the target has branched outside its boundaries, completed and returned control to IDF, breakpoints, watchpoints, and so on.

By default, if the repeated single-step operation reaches code that is within a code section for which IDF Language extract data was not loaded, IDF stops single-stepping. Turning off the STOPSTMT option or using the NOSTOPST option prevents IDF from stopping at these points.

No exit routine processing is performed during, or at the completion of, the STMTSTEP command. As with MRUN or MSTEP, if the STMTSTEP command is

## STOKEY

issued within a macro, use EXTRACT EVENT to determine what type of event completed the command.

If you issue the STMTSTEP command when the PSW is pointing to code that is within a code section for which IDF Language extract data was not loaded, IDF attempts to issue LANGUAGE LOAD for you. This only works if the name of the code section (CSECT) containing the code matches the file name of the extract file. If you do not want IDF to automatically issue these LANGUAGE LOAD commands you should set the AUTOLOAD option to OFF or the NOAUTOLD option to ON.

If the STOPNOP option is OFF or the NOSTOPNP option was used, then IDF does not stop on NOP and NOPR instructions that follow BAL, BALR, BAS, and BASR instructions.

**CMS** If you issue STMTSTEP from within an IDF macro, you should ensure that it is issued through the LPSW Fastpath addressing environment, which is the default environment established when the IDF macro is entered. Using this interface eliminates any SVC linkages between REXX and IDF, so that IDF can provide optimum flexibility in what the target program can itself execute under STMTSTEP. See the usage notes under “MRUN” on page 146 for further details.

**CMS**

For more details see “Controlling Single-stepping your Program” on page 79.

### Return codes

- 0 Operation successful
- 6 Command issued before IDF initialization is complete

---

## STOKEY

Displays the storage key associated with an address.

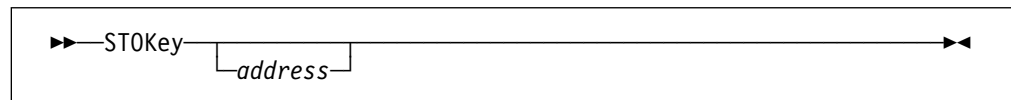

### *address*

A storage location.

If an expression is present on the command line, that expression is used as the argument. If the command line is empty, an attempt is made to determine the address from the cursor position. Failing this, the current execution address is obtained from the PSW.

For information about expressions, see “Address Expressions” on page 73.

### Return codes

- 0 Operation successful

## STOREMAP

Displays information about storage allocation.

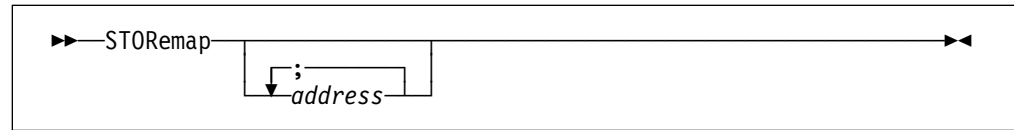

### *address-expression*

A storage address expressions.

The portion of the Storage Allocation Map relevant to the address is displayed.

If no storage address expression is supplied, a complete Storage Allocation Map is displayed.

For information about expressions, see “Address Expressions” on page 73.

The format of the Storage Allocation Map is system dependent.

- On CMS, it is equivalent to that displayed by the CMS STORMAP (ALL command).
- On TSO, it is similar to that displayed by the TSO/E TEST LISTMAP command.
- On VSE, STOREMAP displays a message stating that it is unavailable in this environment.

### **Return codes**

- 0 Operation successful
- 5 Arguments are invalid

## STRUCTURE

Displays the contents of the components of one or more structures.

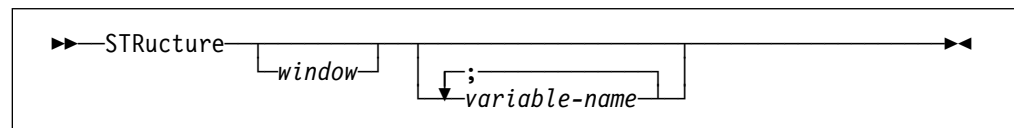

### *window*

An LSM Information window. Select by a Window Specification, or by placing the cursor in the window. If omitted and the cursor is not in a LSM Information window, uses or opens the first LSM Information window.

### *variable-name*

The variable name. Each variable is:

- The major component of a structure, in which case variables within the entire structure are visible.
- A component (member) at an intermediate level within a structure, in which case only variables within that portion of the of the structure are visible.

Use dot-qualification to uniquely identify structure components with ambiguous names.

## STRUCTURE

Simple structure components are defined by name only. You can define components within a based structure by name only, in which case the declared basing is used by IDF, or you can specify an explicit locating expression.

See “Variable Expressions” on page 81 for a complete description of the syntax of the expressions used as STRUCTURE variable name arguments.

Display is *not* supported for:

- imbedded arrays within structures
- arrays of structures

The STRUCTURE display is in the form of a list of the component variables of the structure, in order of definition.

The STRUCTURE display persists until:

- A STRUCTURE command without arguments is issued
- A UNION command without arguments is issued
- The window is closed using a CLOSE command.
- Another IDF Language command such as VARIABLE, ARRAY, CALLERS, PLOCATES, LANGUAGE STATUS, or MAP is issued. These commands update the LSM Information window with new information
- The target program completes execution
- Target program execution progresses beyond the structure's defined scope

If the contents of a variable within the structure change while the program is running to a breakpoint, the changed data is shown on the screen when the breakpoint is reached.

You can change the displayed data by overtyping it.

In EBCDIC display mode, character data equal to X'FF' or below X'40' is displayed as a period character.

In ASCII display mode, character data which does not correspond to a displayable EBCDIC character is displayed as a period character.

If a based structure was respecified, the current basing specification is used.

**Note:** The display of the contents of the variables within a structure may be incorrect if the PSW indicates that execution is in the middle of a statement. This is because the variable may be in a transitional state, not having yet achieved its new value. Variable contents are only certain at the start and end of a statement.

### Examples

```
Str struct1
Str addr(x'20000')->struct1
Str addr(12(R2))->ptr->struct1
Str ptr->ptr2->struct3
Str ptr(3)->ptr->struct1
Str struct1;struct2
Str struct1 ;ptr->struct1
Str struct1 ; struct4
```

---

**SUBSET (CMS only)**

Enters CMS SUBSET.

```
▶▶—SUBset————▶▶
```

Valid unless the target program is a transient.

**Return codes**

- 0 Operation successful
- 6 The target program is a transient and SUBSET destroys the debugging environment

---

**SVC (CMS only)**

Controls the trapping of SVC instructions within the defined limits of the target programs.

```
▶▶—SVC—

|   |
|---|
| Y |
| N |

————▶▶
```

**Y** Enable SVC trapping. Break window displays SVC=Y.

**N** Disable SVC trapping. Break window displays SVC=N.

**Examples**

```
SET SVC Y
SET SVC N
```

---

**SWAP**

Displays the screen image associated with the target program.

```
▶▶—SWAp————▶▶
```

This function is only valid if the SWAP option is specified.

After displaying the target program's screen image, IDF waits until any PF key is pressed before refreshing its display.

**Return codes**

- 0 Operation successful
- 6 Either the SWAP option was not specified, or no screen image was captured

## SYMBOL

Defines an IDF internal (TESTRAN format) symbol.

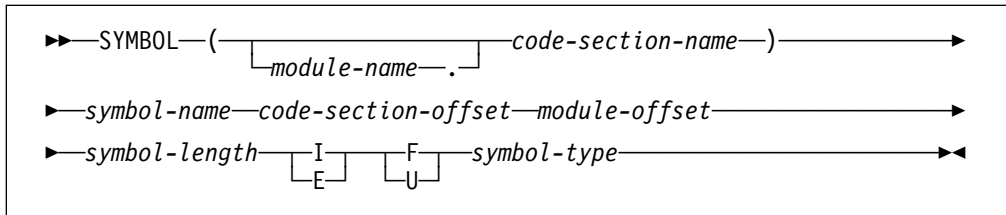
*module-name*

The name of the module within which the symbol occurs. If present, the name must be followed by a period. If omitted, the symbol is assumed to be within the qualified module.

*code-section-name*

The name of the code section within which the symbol occurs.

*symbol-name*

The name of the actual symbol.

*code-section-offset*

The offset of the symbol within the specified CSECT (hex).

*module-offset*

The offset of the symbol within the target module (hex).

*symbol-length*

The total length associated with the symbol (hex).

**I** The symbol is an internal symbol

**E** The symbol is externally known.

**F** The symbol is fully defined.

**U** The symbol is not fully defined. This may occur if no information is available to define the start of the CSECT within which the symbol occurs.

*symbol-type*

The type of the symbol. This is a 2-digit hex value, and is one of the following:

- 00** Space
- 01** CSECT
- 02** DSECT
- 03** COMMON
- 04** Machine Instruction
- 05** CCW
- 06** EQU, LTORG, CNOP, ORG
- 10** C-con
- 14** X-con
- 18** B-con
- 20** F-con
- 24** H-con
- 28** E-con
- 2C** D-con

**30** A/Q-con  
**34** Y-con  
**38** S-con  
**3C** V-con  
**40** P-con  
**44** Z-con  
**48** L-con  
**FE** Self-defining, addr is actual value  
**FF** Unknown, no symbol type available

**Examples:**

```
'SET SYMBOL (ASMIDF) ASMIDF      00000000 00000000 00000060 E F 01'
'SET SYMBOL (VARMVXA.VARASM) BTHING 000009C0 00000050 00000028 I F 10'
```

**TASKS (TSO only)**

Displays information about the executing tasks.

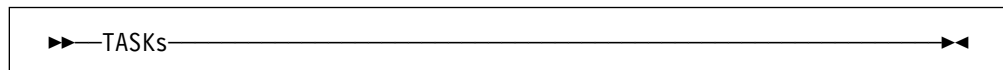

- It is similar to that displayed by the TSO/E TEST LISTMAP command.  
The SVC97 option is needed to allow task information to be obtained.

**Return codes**

0 Operation successful  
 6 Unable to obtain task information

**TITLE**

Sets the title text displayed on the top border line of the selected window.

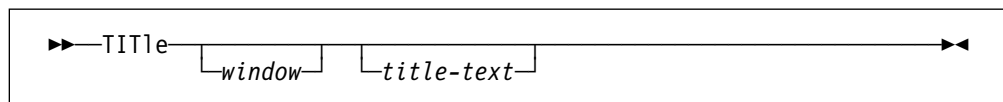
*window*

A window. Select by a Window Specification, or by placing the cursor in the window.

*title*

The new title text for the window. If omitted, the window text reverts to the default for the window.

The new window title text is retained while the window is open, or if the window is minimized and later maximized. If the window is closed, and later reopened, the window text for the new window is the default for the window.

**Return codes**

- 0 Operation successful
- 1 Missing keyword
- 2 Keyword truncated
- 3 Keyword unknown
- 5 Arguments are invalid

**TOP**

Displays source code, starting at lowest available address within the current code section.

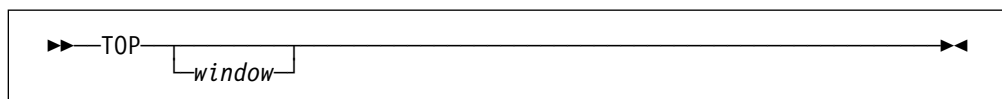
*window*

A Disassembly window. Select by a Window Specification or by placing the cursor in the window. If omitted and the cursor is not in a Disassembly window, uses the first Disassembly window.

**Return codes**

- 0 Operation successful
- 6 No code section definition corresponds to the current address.

**TRIGGER LOAD**

Initiates deferred breakpoint processing for a module.

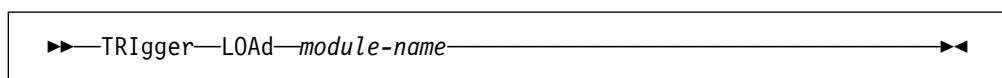
*module-name*

The name of the module.

**Examples**

Given an initial target program *FPROG*, and a program *BPROG* which is loaded through a method that bypasses IDF's DBREAK trapping, you can establish the deferred breakpoints as usual with DBREAK commands. Once *BPROG* is in storage, the command TRIGGER LOAD BPROG causes IDF's deferred breakpoint processing to begin.

```
dbreak (bprog.bedrock)
:
trigger load bprog
```

**Return codes**

- 0 Operation successful
- 1 Missing keyword
- 2 Keyword truncated
- 5 Arguments are invalid

**TYPE**

Displays type information for a variable.

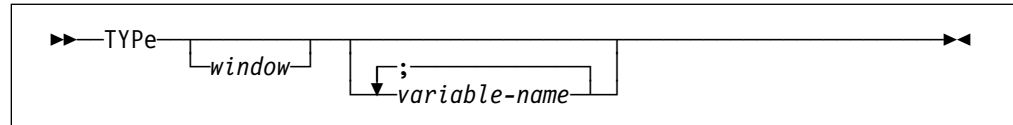
*window*

An LSM Information window. Select by a Window Specification, or by placing the cursor in the window. If omitted and the cursor is not in a LSM Information window, uses or opens the first LSM Information window.

*variable-name*

A variable name.

Only the variable name is relevant in determining the variable type attributes. Extra information such as:

- Locating expressions for based variables
- array index values
- substring ranges

is not needed, and should *not* be specified.

The type attribute information for the variable includes:

- fundamental data type
- user-defined data type
- type hierarchy

The type attribute information display persists until:

- A TYPE command without arguments is issued
- The window is closed with a CLOSE command.
- Another IDF Language command such as VARIABLE, STRUCTURE, ARRAY, CALLERS, PLOCATES, LANGUAGE STATUS, or MAP is issued. These commands update the LSM Information window with new information
- The target program completes execution
- Target program execution progresses beyond the variable's defined scope

**Examples**

```
type stuff
type var1;var2
```

---

**UNION**

A synonym for the command STRUCTURE.

---

**UNTIL**

Executes the target program up to, but not including, an address.

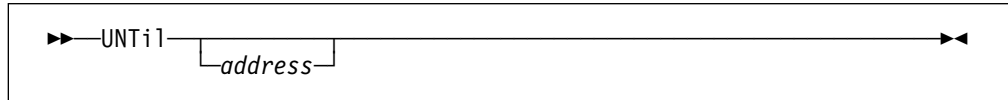
**address**

The address at which IDF should stop. Supply the *address* as part of the command, or by the cursor position.

No exit routine processing is performed during, or at the completion of, the UNTIL command. As with MRUN or MSTEP, if the UNTIL command is issued within a macro, you must use EXTRACT EVENT to determine what type of event completed the command.

**CMS** If you issue UNTIL from within an IDF macro, you should make sure that it is issued through the LPSW Fastpath addressing environment. This is the default environment established when the IDF macro is entered. Using this interface eliminates any SVC linkages between REXX and IDF, so that IDF can provide optimum flexibility in what the target program can itself execute under UNTIL. See the usage notes under “MRUN” on page 146 for further details. **CMS**

**Return codes**

- 0 Operation successful
- 1 No address specified
- 5 Syntax or other error in expression
- 6 Command issued before IDF initialization is complete

---

**UP**

The UP command is a synonym of the PREVIOUS command. For details, see “PREVIOUS” on page 160.

---

**VALUE**

Evaluates an expression and displays its value.

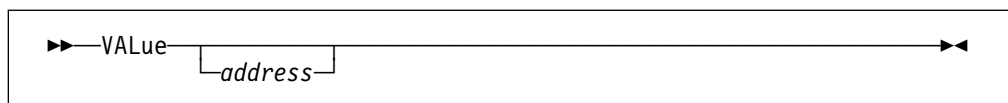
**address**

An IDF address expression.

The value is displayed in hexadecimal format, symbolic format, if applicable, and decimal format.

For information about expressions, see “Address Expressions” on page 73.

### Return codes

- 0 Operation successful
- 5 The expression contained an error

---

## VARIABLE

Displays the contents of one or more variables.

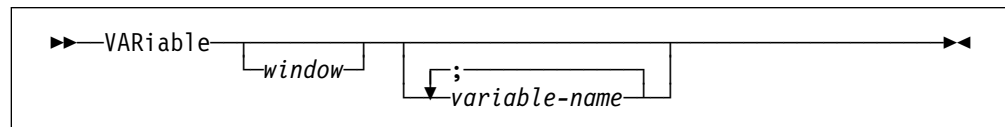

### window

An LSM Information window. Select by a Window Specification, or by placing the cursor in the window. If omitted and the cursor is not in a LSM Information window, uses or opens the first LSM Information window.

### variable-name

A variable name.

Define simple variables by name only. You can define based variables by name only, in which case the declared basing is used by IDF, or you can specify an explicit locating expression.

See “Variable Expressions” on page 81 for a complete description of the syntax of the expressions used for VARIABLE variable name arguments.

If you supply no variable name, the nominated window is closed.

The variable display persists until:

- A VARIABLE command without arguments is issued
- The window is closed with a CLOSE command.
- Another IDF Language command such as STRUCTURE, ARRAY, TYPE, CALLERS, PLOCATES, LANGUAGE STATUS, or MAP is issued. These commands update the LSM Information window with new information
- The target program completes execution
- Target program execution progresses beyond the variable's defined scope

If the contents of the variable change while the program is running to a breakpoint, the changed data is shown on the screen when the breakpoint is reached.

You can change the displayed data by overtyping it.

In EBCDIC display mode, character data equal to X'FF' or below X'40' are displayed as a period character.

In ASCII display mode, character data which does not correspond to a displayable EBCDIC character are displayed as a period character.

If a based variable was respecified, the current basing specification is used.

## VCHANGE

**Note:** The display of the contents of the variables may be incorrect if the PSW indicates that execution is in the middle of a statement. This is because the variable may be in a transitional state, not having yet achieved its new value. Variable contents are only certain at the start and end of a statement.

### Examples

```
var stuff
var addr(x'20000')->stuff
var addr(12(R2))->ptr->stuff(2)
var ptr->ptr2->stuff
var ptr(3)->ptr->stuff
var stuff(-5)
var stuff(1:10)
var stuff(1::25)
var var1;var2
var var1 ;ptr->stuff
var stuff(1:10) ; stuff(30:40)
var chrarray(15,1:10);chrarray(15,1::10)
var chrarray[15,0:9];chrarray[15,0::10]
```

---

## VCHANGE

A special-purpose command used for command logging support.

A rectangular box containing the text 'VChange' with a double arrow on the left and a double arrow on the right, indicating it is a command.

When command logging is active, and a field within a window which is *not* an LSM Information window is changed by operator overtyping, a VC entry is generated in the command log. This reproduces the change when the command log is played back with the RLOG command.

For more details on command logging support, see “Command Record and Playback Features” on page 72.

---

## VERSION

Displays the IDF version information.

A rectangular box containing the text 'VERsion' with a double arrow on the left and a double arrow on the right, indicating it is a command.

The version number is in the form:

ASMIDF Vn.Rn.nn (generated ccyy.mm.dd hh:mm)

### Return codes

0 Operation successful

---

**VS**

Special-purpose command used for command logging support.

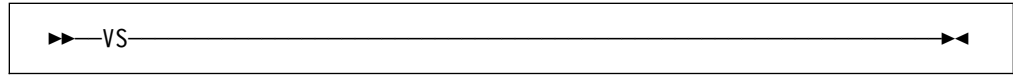

When command logging is active, and a field within an LSM Information window is changed by operator overtyping, a VS entry is generated in the CMDLOG file which reproduces the change when the command log is played back with the RLOG command.

For more details on command logging support, see “Command Record and Playback Features” on page 72.

---

**VSEP**

Enables and disables blank line separating variables.

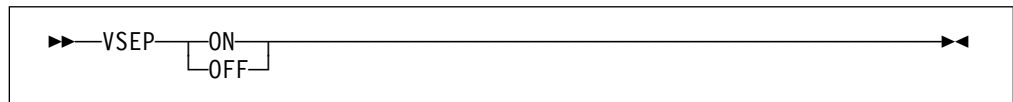
**ON**

Enable the blank line separating variables.

**OFF**

Disable the blank line separating variables.

---

**WATCH**

Supplies a condition that must be true for a particular breakpoint to take effect.

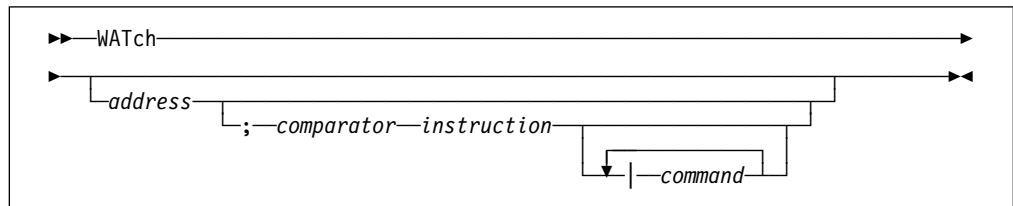
*address*

The address of the breakpoint that is to be conditional.

Supply as part of the command, or from the cursor position. If supplied by means of cursor position and a watchpoint condition is specified, the condition must be preceded by a semicolon. If the *address* is supplied by means of cursor position and the command is a query (no condition supplied) the semicolon need not be supplied.

*comparator*

The condition being checked. Must be:

= EQ != NE > GT < LT >= GE <= LE

## WATCH

If the comparator and following parameters are not supplied the WATCH command is a query. In this case, the existing watchpoint condition for the address is displayed, or a message indicates that no watchpoint is active at the address.

### *instruction*

A System/370™ comparison instruction. This must be one of the following:

<b>CR</b>	compare register
<b>CLR</b>	compare logical register
<b>C</b>	compare
<b>CL</b>	compare logical
<b>CH</b>	compare halfword
<b>CLM</b>	compare logical characters under mask
<b>CLC</b>	compare logical characters

This instruction is coded using standard assembler syntax, with a few exceptions that are detailed below.

The operation of the watchpoint is that when the watchpoint is encountered, the instruction you specified on the WATCH command is executed. If the result of the comparison instruction matches the comparator you specified, the watchpoint condition is considered true and execution of the target program stops, otherwise the target program continues to execute as if there was no breakpoint at the specified address. When the breakpoint is taken, if there is a list of commands associated with the watchpoint, they are executed before control is returned to you. These commands are specified at the end of the WATCH command, separated from the comparator instruction and each other by vertical bars (|). If a command receives a non-zero return code, the remaining commands in the list are not executed.

For example, if you want to stop execution of the target program at the instruction labelled LOOP only when R15 is nonzero, you can issue the following WATCH command and then start the target program through the RUN command:

```
watch loop; ne c r15,=f'0'
```

Departures from standard assembler syntax are:

- When specifying a register, you must use the Rn or rn notation. If you only supply the number of the register it is not recognized.
- Literal data is supported for the F, H, X, and C data types. The maximum length of literal data is 50 bytes. Only one literal value may be specified when using a CLC instruction. Comparing two literals is meaningless as a watchpoint condition.
- When specifying a symbolic address, do *not* also specify a base register, since the result is to access the specified address in storage as indexed by that register.

### *command*

A command that is issued when the breakpoint is taken.

While the condition is false, control passes through the watchpoint and the target program is not stopped. But when the condition is true and the target program is at the breakpoint address, the target program is stopped for inspection.

Watchpoints are cleared by issuing a BREAK command or a SET BREAK OFF command for the address in question.

When you issue a WATCH command that specifies a CLC instruction, the length actually used in the comparison is shown to the right of the watchpoint condition if you query the watchpoint.

If a WATCH command with a condition is issued for an address at which there is a breakpoint, that breakpoint is *converted* into a watchpoint. If commands were specified with the original breakpoint, they are associated with the watchpoint unless commands were specified with the WATCH command.

If a watchpoint whose condition is true is placed within the execution path of the subroutine to be skipped, execution stops at that watchpoint.

### Examples

To set a conditional breakpoint at location X'20040', to be taken when the contents of R3 are equal to the word in ARRAY within CSECT TEST as indexed by R1:

```
watch x'20040' ; = c r3,(test)array(r1)
```

To set a conditional breakpoint at TEST, to be taken if R3 and R4 are not equal:

```
wat test;ne cr r3,r4
```

To set a watchpoint at LOOP, to be taken when the 5 characters pointed to by R1 are thing, any of the following could be used:

```
watc loop; = clc 0(5,r1),=c'thingxxx'
watch loop ; eq clc =c'thing',0(r1)
wat loop; = clc 0(r1),=c'thing'
```

### Return codes

- 0 Operation successful
- 3 Keyword not recognized
- 1 No address specified
- 5 Syntax or other error in expression
- 6 Specified location does not contain a valid instruction, or breakpoint table full

---

## WHERE

Displays the symbolic name for the given address.

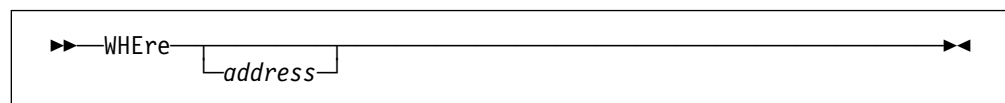

### *address*

A storage location.

If an expression is present on the command line, that expression is used as the argument. If the command line is empty, an attempt is made to determine the address from the cursor position. Failing this, the current execution address is obtained from the PSW.

The WHERE command is similar to the VALUE command:

## XEDEXIT (CMS only)

- If the address corresponds to a location within a module defined to IDF, both commands display the same symbolic name.
- If the address corresponds to an address within a module which is defined in a system control block but not yet defined to IDF:
  - the WHERE command shows this module in the symbolic name
  - the VALUE command displays the hexadecimal address value
- If the address corresponds to a location which is not within any known module, both commands display the hexadecimal address value.

For information about expressions, see “Address Expressions” on page 73.

### Return codes

- 0 Operation successful
- 5 The expression contained an error

---

## XEDEDIT (CMS only)

XEDIT the current exit routine.

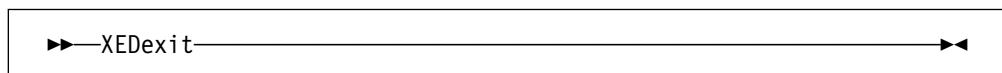

The name of the exit routine that is considered current is by default EXIT. It may be reset at IDF invocation by means of the EXITEXEC option. It may also be reset by a macro with the SET EXITEXEC command.

Be careful when executing CMS commands from within XEDIT. If you are debugging a user-area program, and you invoke another program that runs in the user area while in XEDIT, it destroys the debugging environment. The same care should be taken with routines that run in the transient area.

### Return codes

- 0 Operation successful

---

## ZONED

Sets or queries the format in which the data for zoned decimal variables are displayed.

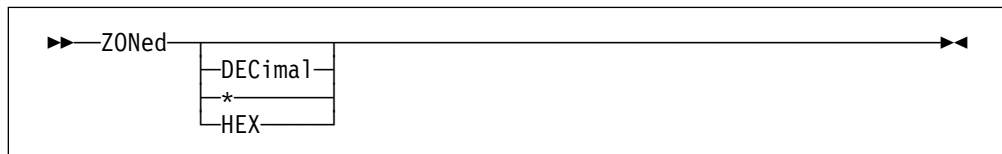

### DECIMAL

Zoned decimal variables are displayed in decimal. This is the initial value.

- \* Zoned decimal variables are displayed in the initial format (DECIMAL).

**HEX**

Zoned decimal variables are displayed in hexadecimal.

If the display format setting is not specified, the current display format for zoned decimal variables are shown in a message.

**Return codes**

- 0 Operation successful
- 2 Keyword truncated
- 5 Not valid zoned decimal variable display format

**ZONED**

---

## **Part 3. Advanced Topics, Macros, Profiles, Exit Routines**

<b>Chapter 11. Writing an IDF Profile</b> . . . . .	<b>204</b>
<b>Chapter 12. Writing IDF macros</b> . . . . .	<b>207</b>
<b>Chapter 13. The IDF Exit Routine</b> . . . . .	<b>214</b>
<b>Chapter 14. REXX Variables Available to Macros</b> . . . . .	<b>219</b>
<b>Chapter 15. EXTRACT Command</b> . . . . .	<b>222</b>

## Chapter 11. Writing an IDF Profile

You can write a profile macro for IDF to change the display colors, PF key assignments, default open windows, set predefined breakpoints for a given program, or perform other functions.

You do not need to have a profile macro, and if you do have one it can be as simple or exotic as you like. One example would be to get the name of the program that is being debugged, use it coupled with the CMS NAMEFIND command to get information about that program, and automatically set a number of breakpoints that apply to it.

Regardless of what uses you have planned for it, the profile must be written in the REXX language.

**CMS** ➤ The profile must have a file type of ASM and can reside on any accessed disk. ◀ **CMS**

**TSO** ➤ The profile must be a member of the partitioned datasets (PDSs) allocated to the ASM DD name. ◀ **TSO**

**VSE** ➤ The profile must reside in a member of a sublibrary in the active PROC chain. ◀ **VSE**

The default file name is PROFILE, but you can specify another file name with the PROFILE option. It is invoked by IDF just before the first display is presented (for more specific information about when the profile is executed, see “When the PROFILE is Executed” on page 205.) The default ADDRESS environment when your profile begins execution is ASM. IDF does not examine the return code from your profile.

To change IDF parameters, use the SET command. You can examine the current settings with the EXTRACT command. You can issue any IDF command from within your profile (though some may not make sense at that point) and you can invoke IDF macros from within your profile.

The following is an example of a simple profile:

```
/* PROFILE ASM */
'set color wryg'
'regs'
'disasm'
'dump'
'dumpmode'
exit
```

*Figure 21. Example of a Simple PROFILE*

This profile begins by changing the display color assignments. It then opens the Current Registers window, the Disassembly window and the Dump window, inverts the default dump mode (symbolic or unformatted), and exits.

When you issue an IDF command in your profile, it behaves exactly as it would if you had pressed that PF key.

**Warning:** Be careful when executing CMS commands from within your profile. If you are debugging a user-area program, and your profile invokes another program that runs in the user area, it will destroy your debugging environment. The same care should be taken with routines that run in the transient area.

## When the PROFILE is Executed

The following sequence of events occurs when IDF is invoked:

1. Perform the first scan of the argument string. The objective during the first scan is to determine which profile should be executed. These options are processed during the first scan:
  - AMODE24
  - AMODE31
  - MODE (CMS only)
  - NOPROFIL
  - PROFILE
2. Execute the specified PROFILE.
3. Perform the second scan of the argument string. The objective during this scan is to set the specified override options. All options not listed above are processed during this scan.
4. If the user's profile did not issue a LOAD command, load symbols and module.
5. Initialize the screen manager.

---

## Command Restrictions Related to PROFILE Execution

During its initialization phase, IDF loads the target program, loads any symbol definitions from the MAP file or load module, and initializes its screen driver. Whether or not these events have occurred determines whether some IDF commands may be issued. The target program and its symbols can be loaded from within the PROFILE by means of the LOAD command; if this is not done explicitly, it is done automatically by IDF after the PROFILE has completed. The screen driver is not initialized until after the PROFILE has completed.

The following commands may only be issued *before* the target program and associated symbols are loaded:

### Program-oriented:

- SET AMODE24 ON
- SET AMODE31 ON
- SET LIBE fn/\$
- On CMS Only
  - SET MODMAP ON
  - SET NOMODMAP ON
  - SET NUCEXT ON
  - SET SYSTEM ON
  - SET TRANS ON
- On TSO Only
  - SET SVC97 ON
  - SET NOSVC97 ON

### Symbol-oriented:

## Writing an IDF Profile

- On CMS Only
  - SET SELFNUCX SYMBOL

The following commands may only be issued *after* the target program and associated symbols are loaded:

### Program-oriented:

- EXTRACT ADSTOPS (CMS only)
- EXTRACT BREAK
- EXTRACT ALET
- EXTRACT AREGS
- EXTRACT LOAD
- EXTRACT REGS
- EXTRACT REGSTOPS (CMS only)
- SET ADSTOPS (CMS only)
- SET ALET
- SET AREG
- SET BASE
- SET BREAK
- SET EPOFFSET
- SET FPR
- SET GPR
- SET LOC
- SET PSW
- SET PSWSTEAL (CMS only)
- SET REGSTOPS (CMS only)
- SET SIZE
- SET FASTPATH ON
- ADSTOPS (CMS only)
- BREAK
- RUN
- STEP

### Symbol-oriented:

- EXTRACT SELFNUCX (CMS only)

The following command may only be issued *before* the PROFILE has completed:

- MODE (CMS only)

The following commands may only be issued *after* the PROFILE has completed:

- EXTRACT ARGUMENT
- EXTRACT CURSOR
- SET CURSOR
- SWAP

## Chapter 12. Writing IDF macros

You can tailor IDF through the use of REXX programs (macros) that IDF invokes. These macros have a default ADDRESS of "ASM".

**CMS** The default ADDRESS environment upon entry to an IDF macro is in the form of a PSW. This instructs REXX to use a LPSW to invoke IDF commands directly, whereas the "address IDF" environment requires a CMSCALL linkage to IDF commands.

The "ASM" subcommand environment is still provided to your macros, and it is still perfectly fine to explicitly direct most IDF commands through this named environment. However, the MRUN and MSTEP commands "behave better" if they are directed through the default "LPSW fastpath" interface.

See the usage notes under "MRUN" on page 146 for MRUN considerations, and see "REXX Linkage Considerations" on page 208 for details about the available methods for invoking IDF commands from REXX. **CMS**

Most IDF commands can be issued within a macro. In particular, you can use the SET and EXTRACT commands to set or extract the settings of various parameters, and the target program's memory and registers.

IDF commands may be abbreviated as shown in Appendix C, "Abbreviations" on page 272. There are many potential uses for IDF macros. A few examples are:

- Provide a "swap" PF key to swap to another set of PF key definitions
- Set a number of predefined breakpoints for a program you are testing repeatedly
- XEDIT the listing file for the program you are debugging
- Redefine the **ENTER** key so that you can use your own syntax for expressions

An IDF macro:

- On CMS, can have any file name that you like, but the file type must be ASM.
- On TSO, it must be a member of the PDSs allocated to the ASM DD name, with any member name that you like.
- On VSE, it must be a member in a sublibrary in the active PROC chain.
- Must be written in the REXX language. It may optionally be compiled by the REXX compiler, in which case the file type (DD name on TSO) of the compiled EXEC must be ASM.

You can invoke a macro in several ways:

- Assuming that your **ENTER** key retains the default assignment of COMMAND, you can enter MACRO, followed by the name of your macro and any arguments it requires, on the command line and press **ENTER**.
- If you have specified the IMPMACRO option, you can type the macro's name on the command line (without prefixing it with MACRO), followed by any necessary arguments, and press ENTER.
- You can set a PF key to MACRO myname args and press the PF key.

- You can issue the macro from within your PROFILE macro.

Your macro can issue any IDF commands you like. These are treated as if they had been invoked by means of a PF key.

Here is an example of a special purpose macro that sets up some breakpoints, opens a Disassembly window, and runs the target program to the first breakpoint:

```
/* ALLOPEN ASM */  
'set break on loop'  
'set break on exit'  
'disasm'  
'run'  
exit 0
```

*Figure 22. Example of a Special Purpose Macro*

IDF propagates the return code from your macro to the caller if it is invoked by another IDF macro.

If the top level macro exits with a nonzero return code, IDF issues a message, so if you want to perform your own message handling you need to exit with a return code of zero.

There are times when one of several macros is setting an IDF option, and it is difficult to determine just where the option is being set. The MACROLOG option helps debug this sort of macro problem. Whenever this option is in effect, all IDF commands that are issued by either an IDF macro or a IDF exit routine are written to the macro log. See "MACROLOG" on page 26 for the name of this log.

**Warning:** Be careful when executing CMS commands from within your macro. If you are debugging a user-area program, and your macro invokes another program that runs in the user area, it destroys your debugging environment. The same care should be taken with routines that run in the transient area.

Numbers in expressions can be specified in explicit (X'123', F'123') or implicit (123) notation. Numbers that do not explicitly specify the base are evaluated according to the current setting of the HEXINPUT option. When writing macros it is recommended that you use explicit base notation.

---

## REXX Linkage Considerations

This section describes the linkages that are used by IDF to invoke REXX (for execution of an IDF macro), and for REXX to in turn invoke IDF commands (as specified within that macro). You should consult the formal REXX documentation and its online HELP files for more complete details of these topics. Here, only a few of the important basics are discussed.

---

## The REXX ADDRESS Statement

The REXX language provides you with explicit and detailed control over how REXX should direct your commands to the appropriate operating system or application component for execution. This "command routing" is controlled by the REXX ADDRESS statement.

Rather than attempt to repeat all of the available REXX literature on this subject, a few simple examples are shown below to give you a basic understanding of how ADDRESS can be used in a REXX exec.

---

## Initial or Default ADDRESS Environment

Upon the initial entry to your exec, REXX provides a default ADDRESS. This is used for any commands until the addressing is changed. For a normal EXEC file, the default addressing supplied by REXX is to the "operating system" so that commands issued within the exec are by default routed to the underlying operating system for execution.

For IDF macros, the default addressing environment is supplied by IDF when it invokes REXX to execute the macro.

**CMS** ➤ The default ADDRESS is in the form of a PSW, telling REXX that it should use its "LPSW Fastpath" mechanism to directly enter IDF command handling. **◀ CMS**

**TSO** ➤ The default ADDRESS is "ASM". **◀ TSO**

**VSE** ➤ The default ADDRESS is "ASM". **◀ VSE**

---

## Overriding the Default ADDRESS Environment

When writing an IDF macro, you may find that you need to issue a command to the underlying operating system, not a command to IDF. You do this by using the REXX ADDRESS statement.

For example:

```
address CMS CMS-command
```

This directs only this command to CMS, with subsequent commands directed to the default environment (ASM).

Compare this with:

```
address CMS
CMS-command
```

This directs *all* commands to CMS until a subsequent address command overrides it.

"Which addressing environment is best for the default?" is generally a decision based upon how many IDF commands are required versus how many host commands are required. And of course you are not restricted to setting one default environment and leaving it that way until the end of your macro; you can change it again at any time.

Of course in an IDF macro, it is expected that most of the commands are IDF commands. And in this case, it is probably best to just leave the default addressing environment (as supplied at entry to your macro) alone, and make "temporary overrides" to other names as you may require for the few (if any) host commands issued.

---

### Saving and Restoring an ADDRESS Environment

When making a "permanent change" to the default addressing environment, it is often required that later in your exec, you restore the original environment again. This can be done in one of three basic ways:

1. By hard-coding a switch from "address CMS" to "address ASM" again, assuming you know that the original default was "ASM".
2. By exploiting a little-known feature of REXX that an "address" statement with no operands "pops" the previous addressing environment. REXX saves just one recent environment this way, but that is often all that is needed.
3. By explicitly saving and restoring the environment. The current environment can be saved by the REXX ADDRESS() function call, as for example "saveenv = address()". It can later be restored by another form of the ADDRESS statement, using ADDRESS VALUE, as for example "address value saveenv". In this case, the "saveenv" is taken to be a REXX variable which holds the environment that is to be set.

There is also some interesting save and restore logic within REXX itself, when calling internal procedures. That topic is beyond the scope of this short introduction to ADDRESS.

**CMS** ➤ Since the default ADDRESS environment on entry to IDF macros on CMS is in the form of a PSW, certain special precautions should be made when switching from one ADDRESS mode to another. In particular, be aware that the PSW format is a nonprintable hexadecimal 8 bytes, which can contain a X'40' byte that might be interpreted as a blank (causing a REXX syntax error perhaps) if misused.

Procedures numbered 2 and 3 in the "Saving and Restoring" examples above are entirely safe for manipulating a PSW form of environment. Procedure 1 depended on the initial environment being "ASM", which is not the case with IDF on CMS, so it should be avoided.

In most cases, there is no need to make a permanent change to the default addressing. You might have just a couple of host commands that warrant a temporary "address CMS" override. So you do not have to worry at all about any of this save and restore complexity.

IDF on CMS still supplies a usual "ASM" subcom environment, so that "address ASM 'WHATEVER'" is supported on TSO, VSE, and CMS. And in almost all cases, it is perfectly acceptable to address IDF commands in this way. Make sure that the "LPSW Fastpath" environment is used for an MRUN command. See "MRUN" on page 146 for further information and cautions. **CMS**

---

### Example macros

Here are some sample macros that illustrate what may be done with macros.

**EX**

This macro determines and display the target of an EXECUTE instruction. It is meant to be invoked with a PF key, but it can also be invoked from the command line with an address.

```

/*REXX -----*/
/*
/* EX      - DISASM the instruction which is the target of an      */
/*          EXecute instruction and display the results in a      */
/*          message.                                             */
/*
/* If the cursor is positioned on an EXecute instruction, or     */
/* the cursor is on the command line but the address of a valid  */
/* EXecute instruction has been entered, or if the PSW points    */
/* to a valid EXecute instruction, dis-assemble the target of    */
/* EXecute instruction and display the results as a message.     */
/*
/*
/*-----*/

/*-----*/
/* Determine which instruction is involved.                       */
/*
/* If EXTRACT ARGUMENT gives RC=-0, IDF will already have issued */
/* an error message. In this case, we exit with RC=-3 to prevent */
/* IDF from overlaying that message with another that says "MACRO */
/* RC=xx" if the argument came from the command line.           */
/*-----*/

'EXTRACT ARGUMENT'
If RC = 0 Then
    Exit -3                /* RC=-3 to prevent msg overlay */

If source = '' Then      /* no address provided          */
    Do
        'EXTRACT VALUE 0(PSW)' /* use next instruction address */
        field = Word(EXPR, 1)
    End

address = field          /* field level resolution      */
'EXTRACT DISASM X''address''
If RC = 0 | instr = '' Then /* not a valid instruction    */
    Do
        'SET MSG Location' address 'does not contain a valid EXecute',
        'instruction'
        'SET ALARM'
        Exit
    End
Parse Var instr 13 index 14 . 15 base 16 offset 19 . 35 opcode .

```

## Writing IDF Macros

```
/*-----*/
/* The opcode must be EX (execute) for this macro. */
/*-----*/
If opcode ^= 'EX' Then
  Do
    'SET MSG' STRIP(opcode) 'is not a valid target for the EX macro'
  Exit
End

/*-----*/
/* Now convert the hex index, base, and offset to an expression */
/*-----*/
reghex = '123456789ABCDEF'
oper   = "X"offset""

If index ^= '0' Then
  oper = oper'+0(R'index(reghex,index)')'

If base ^= '0' Then
  oper = oper'+0(R'index(reghex,base)')'

/*-----*/
/* Dump the indicated memory area and exit */
/*-----*/
'Extract Disasm' oper
'SET MSG' instr

Exit
```

### REGS

This macro toggles the Current Registers window, and if it is opened, places it at the top of the screen.

```
/*REXX -----*/
/*
/* REGS - Toggle the current registers window. */
/*
/* When the REGS window is opened, it will be moved on the IDF */
/* display so that it is the first window. */
/*
/*-----*/

'Regs' /* Toggle REGS window */

'Extract Cursor' /* Obtain window information */
n = Find(display,'REGS') /* Is REGS window present? */
If n ^= 0 Then /* Yes? Force to be 1st window */
  'Order ='n

Exit
```

**SYSCMD**

This macro issues a command to the operating system from the IDF command line. On CMS, transient modules, nucleus extensions and EXECs run. On TSO, any unauthorized command or REXX EXEC runs. On VSE, REXX/VSE commands or REXX programs run.

```

/*REXX -----*/
/*                                                    */
/* Issue the command to the system.                  */
/*                                                    */
/*-----*/

Parse Arg cmd                /* Obtain any operands */
Parse Upper Source OpSys .   /* Determine current OS */

Select

  When (OpSys = 'TSO') Then  /* Handle TSO command */
  Do
    Address TSO cmd          /* Issue command */
    trc = rc
    'Refresh'                /* Refresh WDB screen */
  End

  When (OpSys = 'CMS') Then  /* Handle CMS command */
  Do
    Address CMS cmd          /* Issue command */
    trc = rc
  End

  When (OpSys = 'VSE') Then  /* Handle VSE command */
  Do
    Address VSE cmd          /* Issue command */
    trc = rc
  End

  Otherwise
  Do
    'SET MSG Not on TSO or CMS or VSE - Unable to issue command'
    trc = -3
  End

End

Exit trc

```

---

## Chapter 13. The IDF Exit Routine

An exit routine (also called “exit exec”) is a special purpose IDF macro, which runs when certain events occur.

For general instructions on writing a REXX macro, see “REXX Linkage Considerations” on page 208. For instructions on writing a compiled-language exit routine, see “Writing a Compiled-Language IDF Exit Routine” on page 216.

---

### Naming the Exit Routine

The default name of the macro that serves as the exit routine is "EXIT". Change it at IDF invocation with the EXITEXEC option, or during IDF execution with the SET EXITEXEC command.

---

### Controlling Exit Routine Processing

Exit routine processing is enabled and disabled by the EXITEXEC command.

If exit routine processing is enabled, and the currently defined exit routine exists, then when one of the following events occurs, the exit routine is invoked to determine whether or not to notify the operator:

- IDF is preparing to present its first screen display
- A breakpoint is reached
- The target program branches outside of its memory limits
- A condition exists which puts IDF at risk of losing control
- A program check occurs
- The target program experiences a CMS, MVS or VSE ABEND
- The target program has completed and returned control to IDF
- A single-step operation has just completed
- On CMS only:
  - SVC tracing is in effect and an SVC is reached
  - A monitored storage location is modified
  - A monitored register is modified

The RUNEXIT command also invokes the exit routine

---

### Passing the Reason for Invocation

When the exit routine is invoked, the first token passed to it indicates the reason it was invoked. This could be:

<b>INIT</b>	IDF is preparing to present its first screen display.
<b>BREAK</b>	A breakpoint has been reached.
<b>LIMITS</b>	A target program has branched outside of its memory limits.
<b>WARN</b>	IDF is at risk because of code the target program has, or is about to, execute.

When the event code is "WARN", the last Command window

message display line in the Command window is set to one of these messages:

- ASMMxx025W
- ASMMxx026W
- ASMMxx027W
- ASMMxx091W
- ASMMxx221W

See “Message Numbers and Severity Levels” on page 256 for the text of each message, and the suggested user response.

The contents of the last message should be extracted using the EXTRACT LASTMSG command, and an appropriate action taken by the exit routine.

<b>PROGCHK</b>	A program check has occurred.
<b>ABEND</b>	The target program experienced a CMS, MVS or VSE ABEND.
<b>PFKEY</b>	The RUNEXIT command was issued.
<b>DONE</b>	The target program has completed and returned control to IDF
<b>STEP</b>	A single-step operation was just completed.
<b>QUIT</b>	The operator has issued the QUIT or RCQUIT command.
<b>SVC</b>	CMS Only. SVC tracing is in effect and an SVC instruction has been reached.
<b>ADSTOP</b>	CMS Only. A monitored storage location has been modified.
<b>REGSTOP</b>	CMS Only. A monitored register has been modified.

---

## Looking at the Address

Unless the first token of the argument string passed to the exit routine is "PFKEY", it will also be passed the address at which the event occurred. The argument string passed to the exit routine can be parsed with the following REXX instruction:

```
Parse Upper Arg reason hexvalue . '(' csect ')' symbolic
```

Assume that a breakpoint occurs at label LOOP, which is at location X'2000E' in CSECT ALLOPEN, which begins at X'20000'. After this Parse instruction, the following variables are set:

```
REASON    BREAK
HEXVALUE  0002000E
CSECT     ALLOPEN
SYMBOLIC  ALLOPEN+14
```

**Note:** If the address is outside the target programs defined to IDF, the code section (CSECT) name is omitted and the symbolic name is a second hexadecimal value.

---

### Ignoring the Event

The exit routine indicates to IDF that the event should be ignored and execution of the target program should continue by exiting with a return code of 1. Any other return code indicates that the operator should be notified as usual.

---

### Other Techniques

You can use the EXTRACT command to examine the contents of the registers and main storage, and if necessary you can use host environment commands to examine other parts of the programming environment that lie outside of IDF, for example to see if a given disk file has been created.

If you need to maintain a count of the number of times the exit routine has been entered, or other status information that must carry across its invocations, you can use the SET GLOBAL and EXTRACT GLOBAL commands to access an 80-byte area within IDF that is provided for this purpose.

**Warning:** Be careful when executing CMS commands from within your exit routine. If you are debugging a user-area program, and your exit routine invokes another program that runs in the user-area, it will destroy your debugging environment. The same care should be taken with routines that run in the transient area.

---

### Writing a Compiled-Language IDF Exit Routine

For some applications, like code coverage or path analysis data collection, the performance of an exit routine written in REXX is not adequate. To allow for higher-performance exit routines, IDF provides the ability to use exit routines written in compiled languages.

---

### Specifying that an exit routine is compiled code

To tell IDF that your exit routine is written in a compiled language, set the CMPEXIT option. Here is an example profile which specifies a compiled-language exit routine:

```
/*-----*/
Trace ?0
'MACRO PROFILE PROFILE' /* execute usual profile */
'SET EXIT ASMIDFEX'     /* define name of exit module */
'SET CMPEXIT ON'       /* indicate compiled code exit */
'SET EXITEXEC ON'      /* activate exit routine */
Exit
```

*Figure 23. Specifying A Compiled-Code Exit Routine*

The compiled-code exit routine is invoked to examine the same events as an exit routine that is written in REXX.

On CMS, It is not *required* that you run IDF with PER exploitation disabled, but it *is* highly recommended for applications that collect execution data because:

1. Performance with PER=Y is much slower than with PER=N

2. IDF operation with PER=Y is not as robust as with PER=N

## Requirements for compiled-language exit routines

You must issue a SET EXITEXEC command before setting the CMPEXIT option so that IDF knows the name of the exit routine.

**CMS** Your compiled-language exit routine must be a NUCXLOADable CMS MODULE.

When the SET CMPEXIT ON command is issued, IDF will NUCXLOAD the exit routine.

IDF never invokes the NUCXLOADed exit routine by means of SVC-202. It obtains the entrypoint address from the SCBLOCK associated with the exit routine after it is NUCXLOADed, and invokes it with BALR. **CMS**

**TSO** When the SET CMPEXIT ON command is issued, IDF will load the exit with a LOAD SVC. IDF calls the exit with a BALR after having obtained its address from the LOAD of the exit. **TSO**

**VSE** When the SET CMPEXIT ON command is issued, IDF will load the exit with CDLOAD. IDF calls the exit with a BALR after having obtained its address from the CDLOAD of the exit. **VSE**

The compiled-language exit routine can be written in the language of your choice, so long as it is able to conform to the calling sequence used by IDF. The interface used is designed for PL/I-like exit routines, but an assembler routine can also be used.

At entry to the exit routine, R1 points to a fixed length parameter list:

```
* parameter list passed to compiled-code exit routine
DC      A(calltype)      address of call-type (fullword)
DC      V(subcom)        address of subcommand interface
DC      A(psw)           address of current PSW
DC      A(gpr)           address of current GPRs
DC      A(varname)       address of variable name
DC      A(varnamel)      address of variable name length
DS      A(varval)        address of variable value
DC      A(varvaln)       address of variable value length
DS      A(pstring)       address of pstring
DC      A(pstringl)      address of pstring length
```

Figure 24. Parameter List Passed to Compiled-Code Exit Routine

The first parameter is the call-type. The exit routine is invoked on event occurrence, and if it issues any EXTRACT commands during its processing, it is re-entered (recursively) to receive the values normally set into REXX variables. A call-type of 0 (zero) indicates an EVENT invocation. A call-type of 4 indicates a VARIABLE invocation.

The exit routine, when entered, must inspect the call-type as its first order of business. It will not be re-entered unless it issues EXTRACT commands to the

## The IDF Exit Routine

IDF command processor, but if it is re-entered the call-type value will have changed to 4, indicating a VARIABLE invocation.

The remaining parameters are either invariant, or apply to only one type of call.

All of the parameters passed and their meanings are:

1. **Address of call-type:** The call-type is contained in a fullword. A value of 0 (zero) indicates an EVENT call, and a value of 4 indicates a VARIABLE call.
2. **Address of subcommand interface:** This address is the start of the IDF subcommand processor. The exit routine may call the subcommand processor to execute IDF commands. It must enter the subcommand processor with R1 containing the address of a parameter list as follows:

```
          DC    A(CSTRING)
          DC    A(CSTRINGL)
          ...
CSTRING DC    C'whatever command string'
CSTRINGL DC   A(L'CSTRING)
```

If an EXTRACT command is issued, the exit routine must be prepared to receive the variables extracted. It will therefore be recursively re-entered and the call-type will indicate a VARIABLE call.

3. **Address of current PSW:** This word points to the target program's current PSW.
4. **Address of current GPRs:** This word points to the target program's current GPRs.
5. **Address of variable name:** (Applicable only when call-type is 4.) This word points to the start of a character string which is the name of the extracted variable.
6. **Address of variable name length:** (Applicable only when call-type is 4.) This word points to a fullword containing the length of the variable name in bytes.
7. **Address of variable value:** (Applicable only when call-type is 4.) This word points to a character string which represents the current value of the extracted variable.
8. **Address of variable value length:** (Applicable only when call-type is 4.) This word points to a fullword containing the length of the current value of the extracted variable in bytes.
9. **Address of pstring:** (Applicable only when call-type is 0.) This word points to the start of a character string describing the event causing the exit routine's invocation. The contents of the character string are described in Chapter 13, "The IDF Exit Routine" on page 214.
10. **Address of pstring length:** (Applicable only when call-type is 0.) This word points to a fullword which contains the number of bytes in the parameter string which describes the event causing the exit routine's invocation.

---

## Chapter 14. REXX Variables Available to Macros

IDF provides the EXTRACT command so that an IDF macro can obtain information about IDF, IDF Language Support, or the target program and the environment in which it is executing.

The EXTRACT command returns data in:

- one or more fixed variables, or fixed stemmed arrays
- a stemmed array controlled by the STEM command

A REXX stemmed array will consist of "*stem.n*", where *stem.0* contains the number of items in the stemmed variable array, and the remaining items contain the requested information.

---

### REXX Variables with Fixed Names

The following table lists all REXX variables whose names are fixed, and the EXTRACT command that sets each variable:

<b>Variable</b>	<b>Command Which Sets Variable</b>
<b>ADSTOP.n</b>	EXTRACT ADSTOP
<b>ALET</b>	EXTRACT ALET
<b>AR.n</b>	EXTRACT AREGS
<b>AREA</b>	EXTRACT LOAD
<b>BREAK.n</b>	EXTRACT BREAK
<b>COLORS</b>	EXTRACT COLORS, EXTRACT COLOURS
<b>COMMAND</b>	EXTRACT CMDMSG
<b>CPDISASM</b>	EXTRACT CURSOR
<b>CPDUMP</b>	EXTRACT CURSOR
<b>CSECT</b>	EXTRACT DISASM
<b>DISPLAY</b>	EXTRACT CURSOR
<b>EPOFFSET</b>	EXTRACT LOAD
<b>EVENT</b>	EXTRACT EVENT
<b>EXACT</b>	EXTRACT ARGUMENT, EXTRACT CURSOR
<b>EXITEXEC</b>	EXTRACT EXITEXEC
<b>EXPR</b>	EXTRACT VALUE
<b>FIELD</b>	EXTRACT ARGUMENT, EXTRACT CURSOR
<b>FPR.n</b>	EXTRACT REGS
<b>GLOBAL</b>	EXTRACT GLOBAL
<b>GPR.n</b>	EXTRACT REGS, EXTRACT REGSTOPS
<b>HEXCUSR</b>	EXTRACT CURSOR
<b>ICOUNT</b>	EXTRACT ICOUNT
<b>INDIRECT</b>	EXTRACT ARGUMENT, EXTRACT CURSOR
<b>INSTR</b>	EXTRACT DISASM
<b>LOADLIB</b>	EXTRACT LOAD
<b>LSM</b>	EXTRACT LOAD
<b>MEMAREA</b>	EXTRACT LOCATION, EXTRACT LOCATION ALET
<b>MODE</b>	EXTRACT MODE
<b>MODULES.n</b>	EXTRACT MODULES
<b>MSG1</b>	EXTRACT CMDMSG
<b>MSG2</b>	EXTRACT CMDMSG
<b>NAME</b>	EXTRACT LOAD

## REXX Variables Available to Macros

<b>NINSTR</b>	EXTRACT DISASM
<b>NPDISASM</b>	EXTRACT CURSOR
<b>NPDUMP</b>	EXTRACT CURSOR
<b>OAR.n</b>	EXTRACT AREGS
<b>OFFSET</b>	EXTRACT LOAD
<b>OFPR.n</b>	EXTRACT REGS
<b>OGPR.n</b>	EXTRACT REGS
<b>OPSW</b>	EXTRACT REGS
<b>OPTION</b>	EXTRACT OPTIONS
<b>ORIGIN</b>	EXTRACT LOAD
<b>PBREAK.n</b>	EXTRACT BREAK
<b>PER</b>	EXTRACT PER
<b>PFK.n</b>	EXTRACT PFK
<b>PLIST</b>	EXTRACT PLIST
<b>PSW</b>	EXTRACT REGS
<b>QUALIFY</b>	EXTRACT QUALIFY
<b>SELFNUCX</b>	EXTRACT SELFNUCX
<b>SIZE</b>	EXTRACT LOAD
<b>SKIP.n</b>	EXTRACT SKIPSTEP
<b>SOURCE</b>	EXTRACT ARGUMENT, EXTRACT CURSOR
<b>STEM</b>	EXTRACT LANGUAGE STEM
<b>SVC</b>	EXTRACT SVC
<b>SYMBOL</b>	EXTRACT LOAD
<b>SYMBOL.n</b>	EXTRACT SYMBOLS
<b>VERSION</b>	EXTRACT VERSION
<b>WINDOW.n</b>	EXTRACT WINDOWS

---

## REXX Variables with Variable Names

The following table lists the commands that return data in the REXX stemmed array whose name is controlled by the STEM command. See Chapter 15, “EXTRACT Command” on page 222 for more details.

The name of the stemmed variable array defaults to **LSM.** and should normally not be altered.

- EXTRACT ARRAY
- EXTRACT CALLERS
- EXTRACT LANGUAGE ARGS
- EXTRACT LANGUAGE CMDS
- EXTRACT LANGUAGE COMMANDS
- EXTRACT LANGUAGE OPTIONS
- EXTRACT LANGUAGE STATUS
- EXTRACT LANGUAGE VERSION
- EXTRACT MAP
- EXTRACT MSTATUS
- EXTRACT NAMES
- EXTRACT PARMS
- EXTRACT PLOCATES
- EXTRACT QUERY
- EXTRACT SCOPE
- EXTRACT SCRVAR
- EXTRACT SOURCE
- EXTRACT STRUCTURE

- EXTRACT TYPE
- EXTRACT VARIABLE
- EXTRACT VDCL
- EXTRACT VDECLARE
- EXTRACT VLOC
- EXTRACT VVALUE

---

## Chapter 15. EXTRACT Command

---

### Function

The EXTRACT command is used to return various types of information to a macro through REXX variables or stemmed arrays. This includes:

- IDF options
- IDF settings
- IDF invocation parameter string
- user register values
- user storage values
- user variable data
- user program information
- user symbol information

The following sections provide a brief description of the available EXTRACT commands.

---

### Return Codes

The EXTRACT command returns the following return codes:

- 0** Operation successful
  - 1** Missing keyword
  - 2** Keyword truncated
  - 3** Keyword unknown
  - 4** Error attempting to set a REXX variable  
Out of memory or EXECCOMM error
  - 5** Arguments are invalid
  - 6** Unable to honor EXTRACT command at this time  
This return code will occur if, for example, you attempt to EXTRACT BREAK within your PROFILE before the target program has been loaded into memory.
  - 7** The command cannot run in this environment  
This may be because this command is supported for a specified OS only (CMS, or TSO), or that you must be in an ESA environment.
- 

### ADSTOPS (CMS only)

Returns all the currently set storage modification stops.

►►—EXTRACT—ADSTops—◄◄

**REXX Variables Set****ADSTOP.0** Number of AdStops set**ADSTOP.n** The next AdStop

---

**ALET**

Return the ALET used to qualify the dataspace to be displayed in a Dump window.

Diagram showing the command syntax: >> EXTRACT ALET number-of-bytes <<

*window*

A Dump window Select by a Window Specification, or by placing the cursor in it. If omitted and the cursor is not in a Dump window, returns the ALET for the first Dump window.

You must be in an ESA environment for this command to work.

**REXX Variables Set****ALET** The ALET of the selected window in EBCDIC HEX representation**Example**

EXTRACT ALET =3

---

**AREGS**

Returns the Access Registers in EBCDIC HEX representation.

Diagram showing the command syntax: >> EXTRACT AREGS <<

You must be in an ESA environment for this command to work.

**REXX Variables Set****AR.0 - AR.15**

Current values of the Access Registers

**OAR.0 - OAR.15**

Previous values of the Access Registers

---

**ARGUMENT | ARGS**

Returns address argument from the command line or cursor position as appropriate.

Diagram showing the command syntax: >> EXTRACT ARGUMENT [ARGS] argument <<

*argument*

An expression. If it is invalid, the EXTRACT ARGUMENT command completes with a nonzero return code. If EXTRACT ARGUMENT completes with a

## EXTRACT commands

nonzero return code, an appropriate error message is placed on the screen by IDF and the macro should exit with RC=-3, to stop IDF overlaying the error message with another message stating the macro return code (if the macro exits with a nonzero RC), or clearing the command line (if the macro exits with RC=0).

If the command line is empty, IDF attempts to determine an address based on cursor position.

### REXX Variables Set

<b>SOURCE</b>	Contains the source of the argument: <b>blank</b> No argument was available <b>COMMAND</b> The argument was obtained from the command line <b>PSWGPR</b> The argument was obtained from cursor position within the Current Registers window or the Old Registers window <b>DISASM</b> The argument was obtained from cursor position within the Disassembly window <b>DUMP</b> The argument was obtained from cursor position within the Dump window
<b>FIELD</b>	8-character hexadecimal address; if determined from cursor position, the address corresponds to the first byte of the field in which the cursor was positioned.
<b>EXACT</b>	8-character hexadecimal address; if determined from cursor position in a dump display, the address corresponds to the exact byte of the field in which the cursor was positioned. Otherwise EXACT is the same as FIELD.
<b>INDIRECT</b>	8-character hexadecimal address. If determined from the cursor position in the Disassembly window, and the cursor was positioned at the first instruction shown, and that instruction is a branch, the value in INDIRECT is the effective address of the branch instruction. If determined from cursor position in a Dump window, and the cursor was in the first field displayed, and that field is a fullword, INDIRECT will contain the contents of the field rather than its address. Otherwise INDIRECT is the same as FIELD.

If the argument was determined from the command line, variables FIELD, EXACT, and INDIRECT will contain the same value.

EXTRACT ARGUMENT follows the rules for obtaining arguments that are described in “Arguments and Cursor Positioning” on page 75.

---

## ARRAY

Returns information about the indicated array elements.

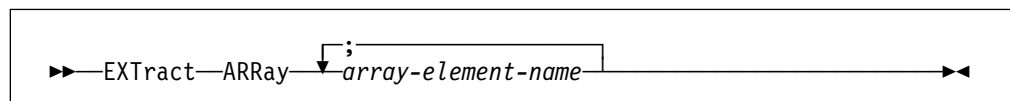

*array-element-name*

An array element name.

The name of the stemmed variable array defaults to LSM. and may be set by the LANGUAGE STEM command (see “LANGUAGE STEM” on page 130).

The EXLIMIT command (see “EXLIMIT” on page 111) is used to control the maximum stemmed array index value.

### REXX Variables Set

*stemname.0*

Number of items in the stemmed array

*stemname.n*

Information about the array elements

---

## BREAK

Returns all the currently set breakpoints or, if an expression was specified, just the breakpoint at that address.

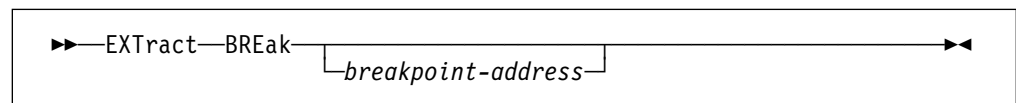

*breakpoint-address*

The address of the breakpoint that is required.

### REXX Variables Set

**BREAK.0** Number of breakpoints set

**BREAK.n** The next breakpoint

**PBREAK.0** Number of PSWSTEAL breakpoints set

**PBREAK.n** The next PSWSTEAL breakpoint

---

## CALLERS

Returns information for each generation in the program caller hierarchy, including:

- Current execution location, as:
  - Memory location, in IDF symbolic format  
(module.CSECT)Stmt#nnnnn+offset
  - Logical location  
program-block-name+offset
- Save Area Header
- Save Area register values, if applicable

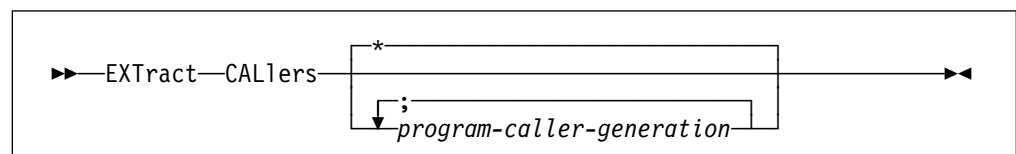

## EXTRACT commands

\* Return information for all caller generations.

*program-caller-generation*

A caller generation.

The program caller generations numbering convention is:

- 0 current program
- 1 parent (caller)
- 2 grand parent (caller of caller), and so on

The SAREGS command (see “SAREGS” on page 171) is used to enable or disable the return of the Save Area header and registers in the CALLERS data. The Save Area registers are formatted according to the ROWSTYLE option setting.

The SALIMIT command (see “SALIMIT” on page 170) controls the maximum depth of the CALLERS data. This is intended to prevent problems when the program call chain is damaged, or is of unexpected depth (due to runaway recursion).

The name of the stemmed variable array defaults to LSM. and is set by the LANGUAGE STEM command (see “LANGUAGE STEM” on page 130).

The EXLIMIT command (see “EXLIMIT” on page 111) controls the maximum stemmed array index value.

### REXX Variables Set

*stemname.0*

Number of items in the stemmed array

*stemname.n*

Information about the program caller hierarchy.

---

## CMDMSG

Returns the current contents of the command line and message lines as currently displayed in the IDF Command window.

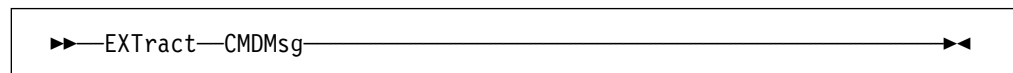

Also see “LASTMSG” on page 234.

All messages generated by IDF are returned with message prefixes, even if the MSGID option is OFF and the message is displayed without the message id. User messages issued with a SET MSG command do not have a message id.

### REXX Variables Set

**COMMAND** The current value of command line

**MSG1** The current value of message line 1

**MSG2** The current value of message line 2



## EXTRACT commands

<b>HEXCUSR</b>	Three, blank separated, 2-character hexadecimal value which represents the exact position of the cursor on the screen. These values represent the window containing the cursor, the row within the window of the cursor, and the column within the window of the cursor, respectively.
<b>CPDISASM</b>	Symbolic address as described below, corresponding to the address of the first byte shown in the first Disassembly window.
<b>CPDUMP</b>	Symbolic address as described below, corresponding to the address of the first byte shown in the first Dump window.
<b>NPDISASM</b>	Symbolic address as described below, corresponding to the address of the first byte that is shown in the first Disassembly window if it is scrolled forward.
<b>NPDUMP</b>	Symbolic address as described below, corresponding to the address of the first byte that is shown in the first Dump window if it is scrolled forward.

### Symbolic addresses

Symbolic addresses consist of several tokens, and can be parsed with the following REXX instruction (where NAME is the variable containing the symbolic address):

```
Parse Var name hexvalue . '(' csect ')' symbolic
```

After this Parse instruction, the following variables contain, for example:

```
NAME      0002000C (ALLOPEN) ALLOPEN+12  
HEXVALUE 0002000C  
CSECT    ALLOPEN  
SYMBOLIC ALLOPEN+12
```

If the address is outside of the target programs defined to IDF, the code section (CSECT) name is omitted and the symbolic name is a second hexadecimal value.

If the address is outside the currently qualified module or the FULLQUAL option is ON, then the code section name as defined above is *module.csect*, where *module* is the name of module containing the address.

EXTRACT CURSOR follows the rules for obtaining arguments that are described in “Arguments and Cursor Positioning” on page 75 except that it does not examine the command line for an argument.

---

## DISASM

Returns information about the specified instruction.

```
▶▶—EXTRACT—DISASM—instruction-address————▶▶
```

*instruction-address*

Any IDF expression. It is resolved to an address and used to find the instruction to be disassembled.

**REXX Variables Set**

<b>INSTR</b>	Disassembled instruction text; blank if the address specified by the expression does not contain a valid instruction, otherwise: <b>Columns Contents</b> <b>01-08</b> Instruction address <b>10-24</b> Hexadecimal instruction value in halfwords <b>26-33</b> Label <b>35-39</b> Operation code <b>41 on</b> Operands
<b>NINSTR</b>	Address of the next sequential instruction, as 8-digit hexadecimal (meaningless if INSTR is blank). The address represents the "sequential flow" next instruction.  <div style="border: 1px solid black; padding: 2px; display: inline-block;">CMS</div> → IDF knows that a fullword bitstring follows an SVC 201, that a fullword error return address may follow an SVC 202, and that a halfword code follows an SVC 203, and adjusts the returned NINSTR address accordingly. IDF also recognizes when the target program has stolen the SVC New PSW, and if so returns the entry-point address of its SVC FLIH when an SVC is disassembled.
<b>NINSTRB</b>	Address of the non-sequential (that is, a branching) flow instruction, if any, as 8-digit hexadecimal, or blank if NINSTR represents the only possible next instruction. NINSTRB is set for conditional branch instructions, and represents the next instruction if that conditional branch is taken. ← <div style="border: 1px solid black; padding: 2px; display: inline-block;">CMS</div>
<b>NADDR</b>	Address of the next instruction or data which follows the nominated instruction. This is usually the same as the NINSTR address for sequential flow. But the NINSTR may be different due to IDF's recognition (on CMS) of special flows when an SVC is nominated.
<b>CSECT</b>	The name of the code section (CSECT) within which the instruction occurs (meaningless if INSTR is blank).  If the address is outside the currently qualified module or the FULLQUAL option is ON, then the code section name is <i>module.csect</i> , where <i>module</i> is the name of module containing the address.

Be careful when using addresses obtained from EXTRACT DISASM in other IDF commands. Displacements in disassembled instructions may be shown in either explicit hex notation or implied decimal notation (depending on the HEXDISP option). If you use a displacement that is given in implied decimal notation, but the default input base is hex, the address will not be evaluated as expected.

The recommended procedure for working with expressions obtained from EXTRACT DISASM is to save the default base setting and set it to decimal.

The calculation of the NINSTR and NINSTRB addresses are done using the current target program register values at the time of the EXTRACT DISASM command.

For example a BRANCH instruction might use a base register of R11 for its branching. If the EXTRACT DISASM expression address resolves to the current PSW location, this is no problem whatsoever, since the register values will be correct at that point. However, if the expression represents an address other than the current PSW instruction, the register values might not match what they would be at the point of naturally executing that instruction, and so the NINSTR and NINSTRB address may be incorrect.

---

## EVENT

Returns data about the last event which occurred in the target program.

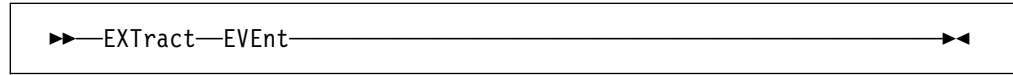

### REXX Variables Set

**EVENT** Event information, in the same format as the argument string passed to an exit routine; see Chapter 13, “The IDF Exit Routine” on page 214 for a description of this information.

**COMMAND** The name of the command which last started the target executing.

---

## EXITEXEC

Returns the name of the currently assigned exit routine.

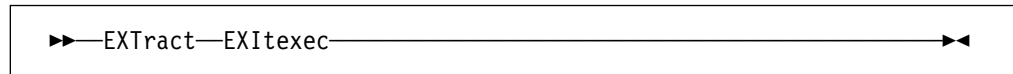

### REXX Variables Set

**EXITEXEC** The name of the currently assigned exit routine

---

## GLOBAL

Returns the current setting of the IDF global variable.

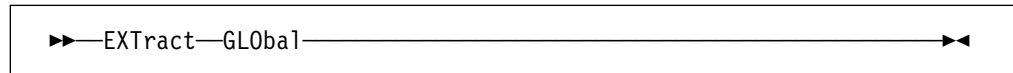

This global variable is initially set to blanks by IDF. It may be reset by any IDF macro through the SET GLOBAL command, and is intended for macro-to-macro communication.

### REXX Variables Set

**GLOBAL** The last setting of the IDF global variable

---

## GLOBAL STEM

Reads the data in the specified Global Storage stems, and write it to the same named REXX stemmed arrays.

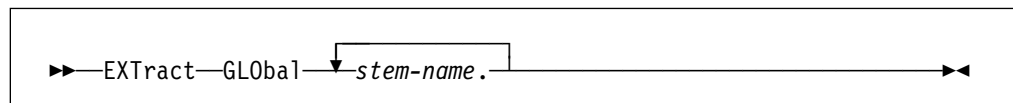

*stem-name*

A Global Storage stem name.

The terminating period is needed for each name.

**REXX Variables Set***stemname.0*

Number of items in the stemmed array

*stemname.n*

Information for the stemmed array element

---

**GLOBAL STEMS**

Returns the names of all currently defined Global Storage stems.

**REXX Variables Set****GLOBALS.0**

The number of Global Storage stems defined

**GLOBALS.n**

The name of the nth Global Storage stem

---

**GSTATUS**

Returns information about the storage used to contain the Global Storage data which has been loaded with SET GLOBAL STEM commands. This includes:

- number of Global Storage stems
- Global Storage storage consumption (total, direct, pooled)
- Global Storage storage pool utilization, including the number of AREAs in the pool which are unused

The name of the stemmed variable array defaults to LSM. and may be set by the LANGUAGE STEM command (see “LANGUAGE STEM” on page 130).

The EXLIMIT command (see “EXLIMIT” on page 111) is used to control the maximum stemmed array index value.

**REXX Variables Set***stemname.0*

Number of items in the stemmed array

*stemname.n*

Information about the LSM Information window command arguments

---

**ICOUNT**

Returns the number of instructions executed since the last ICOUNT command.

## EXTRACT commands

### REXX Variables Set

**ICOUNT** The number of instructions executed.

---

## LANGUAGE ARGUMENTS | ARGS

Returns the current command arguments for each LSM Information window.

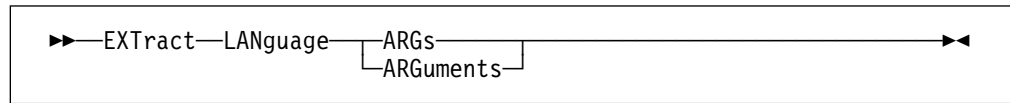

The name of the stemmed variable array defaults to LSM. and may be set by the LANGUAGE STEM command (see “LANGUAGE STEM” on page 130)

The EXLIMIT command (see “EXLIMIT” on page 111) is used to control the maximum stemmed array index value.

### REXX Variables Set

*stemname.0*

Number of items in the stemmed array

*stemname.n*

Information about the LSM Information window commands

---

## LANGUAGE COMMANDS | CMDS

Returns the current command for each LSM Information window.

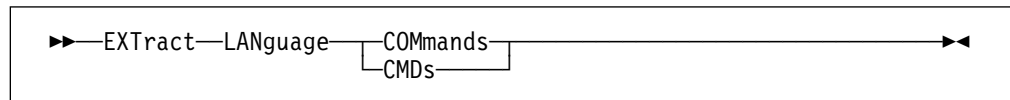

The name of the stemmed variable array defaults to LSM. and may be set by the LANGUAGE STEM command (see “LANGUAGE STEM” on page 130).

The EXLIMIT command (see “EXLIMIT” on page 111) is used to control the maximum stemmed array index value.

### REXX Variables Set

*stemname.0*

Number of items in the stemmed array

*stemname.n*

Information about the LSM Information window commands

---

## LANGUAGE OPTIONS

Returns information as to the current value of the various IDF Language Support settings.

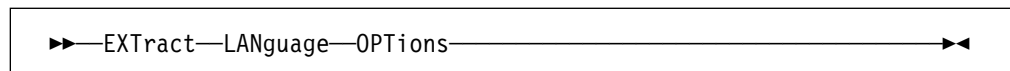

To obtain the current value of an individual IDF setting, the preferred method is to use the EXTRACT Query command.

The name of the stemmed variable array defaults to LSM. and may be set by the LANGUAGE STEM command (see “LANGUAGE STEM” on page 130).

The EXLIMIT command (see “EXLIMIT” on page 111) is used to control the maximum stemmed array index value.

### REXX Variables Set

*stemname.0*

Number of items in the stemmed array

*stemname.n*

Information about the current value of the various IDF Language Support settings.

---

## LANGUAGE STATUS

Returns information about about the extract files which have been loaded with LANGUAGE LOAD commands.

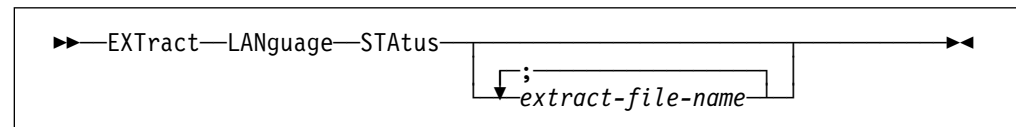

*extract-file-name*

An extract file name. Information is returned only for those compiles which were contained within the specific extract files. If no extract file names are specified, the default is to extract information for all currently loaded (with LANGUAGE LOAD) language extract files.

The name of the stemmed variable array defaults to LSM. and may be set by the LANGUAGE STEM command (see “LANGUAGE STEM” on page 130).

The EXLIMIT command (see “EXLIMIT” on page 111) is used to control the maximum stemmed array index value.

### REXX Variables Set

*stemname.0*

Number of items in the stemmed array

*stemname.n*

Information about the specified extract files.

---

## LANGUAGE STEM

Returns the name of the REXX stemmed variable array which is used to return information to an IDF macro as a result of all subsequent EXTRACT LANGUAGE commands, as well as a number of other EXTRACT commands.

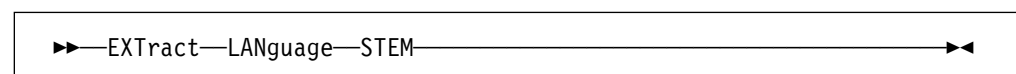

### REXX Variables Set

**STEM**        Name of the REXX stemmed variable array

---

## LANGUAGE VERSION

Returns the IDF Language Support Version Information.

▶▶—EXTRACT—LANGUAge—VERsion—————▶▶

The name of the stemmed variable array defaults to LSM. and may be set by the LANGUAGE STEM command (see “LANGUAGE STEM” on page 130).

The EXLIMIT command (see “EXLIMIT” on page 111) is used to control the maximum stemmed array index value.

### REXX Variables Set

*stemname.0*

Number of items in the stemmed array

*stemname.1*

IDF Language Support version information text.

This has the form:

"ASMLANG Vn.Rn.nn (generated ccy.ddd hh:mm)".

---

## LASTMSG

Returns the last 10 messages that were issued by SET MSG commands, or as a result of the execution of other IDF commands.

▶▶—EXTRACT—LASTMsg—————▶▶

All messages generated by IDF are returned with message prefixes, even if the MSGID option is OFF and the message is displayed without the message id. User messages issued with a SET MSG command do not have a message id.

All messages generated by IDF are returned, even if the MSGMODE option is OFF and the message was not actually displayed in a Command window message display line.

### Example

The LASTMSGM values of 0 and 1 may be used directly in Boolean tests, such as:

```
'EXTRACT LASTMSG'  
Do I = 1 to lastmsg.0  
  If lastmsgm.i Then  
    Say lastmsg.i  
End
```

**REXX Variables Set****LASTMSG.0**

Number of items in the stemmed array

**LASTMSG.n**

The message text (with message id, if available), of the last *n* messages, with the most recent message in LASTMSG.1.

**LASTMSGM.0**

Number of items in the stemmed array

**LASTMSGM.n**

The value of the MSGMODE setting at the time the *n*th message was issued. This is one of:

**0** MSGMODE was OFF

**1** MSGMODE was ON

---

**LOAD**

Returns information about the program specified when IDF was invoked and where it is loaded in memory.

▶▶—EXTRACT—LOAD—▶▶

**REXX Variables Set**

**NAME** The name of the program module

**AREA** The area in which the program is loaded:

**USER** User program area

**TRANS** CMS Transient area at location  
X'0E000'-X'0FFFF'

**NUCEXT** CMS Nucleus Extension area

**SYMBOL** The number of symbols defined

**ORIGIN** The program's origin in memory, 8-digit hexadecimal

**EPOFFSET** The offset within the program of its entrypoint, 8-digit hexadecimal

**OFFSET** The current value of the offset (set by the OFFSET command), 8-digit hexadecimal

**SIZE** The size of the program in bytes, 8-digit hexadecimal

**LOADLIB** The name of the loadlib specified, or blank

---

**LOCATION**

Extracts bytes of main memory.

▶▶—EXTRACT—LOCATIOn—*number-of-bytes*—*start-address*—▶▶

*number-of-bytes*

Number of bytes of main memory to be extracted.

*start-address*

An expression giving the starting address.

If the expression contains an access register then the storage that is extracted

## EXTRACT commands

will come from the dataspace identified by the ALET in the referenced access register.

### REXX Variables Set

**MEMAREA** Contents of the specified memory area

The EXTRACT LOCATION command allows you to retrieve storage within your program's defined limits. For more details on your program's defined limits and how to change them, see (CMS) "Your Program's Defined Limits" on page 50 and (TSO) "Your Program's Defined Limits" on page 42.

If the TRACEALL option or the RISK option is set, you may be able to retrieve storage beyond the program's defined limits.

### Example

```
EXTRACT LOCATION 8 0(R1)
```

This example sets REXX variable MEMAREA to the contents of 8 bytes pointed to by the target program's R1.

```
EXTRACT LOCATION 8 0(AR2)
```

This example sets REXX variable MEMAREA to the contents of 8 bytes pointed to by the target program's R2 in the dataspace identified by the ALET in AR2.

---

## LOCATION ALET

Extracts bytes of dataspace.

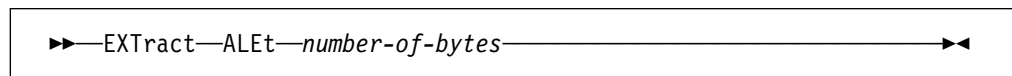

*number-of-bytes*

Number of bytes of main memory to be extracted.

### REXX Variables Set

**MEMAREA** Contents of the specified memory area

### Example

```
EXTRACT LOCATION ALET 10003 X'1000'
```

```
EXTRACT LOCATION ALET 10004 0(R1)
```

---

## MAP

Returns information about the location of all modules and code sections known to IDF, as well as the name of the extract file which may be associated with each code section.

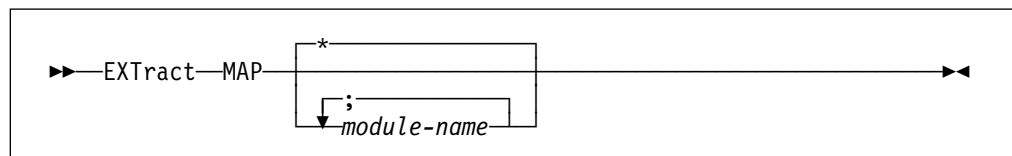

\* Extract information for all currently known modules.

*module-name*

A module name. Information is returned for the nominated modules, and the CSECTs which are a part of those modules.

The name of the stemmed variable array defaults to LSM. and may be set by the LANGUAGE STEM command (see “LANGUAGE STEM” on page 130).

The EXLIMIT command (see “EXLIMIT” on page 111) is used to control the maximum stemmed array index value.

### REXX Variables Set

*stemname.0*

Number of items in the stemmed array

*stemname.n*

Information about the module and code sections

---

## MODE (CMS only)

Returns the current file mode.

▶▶—EXTRACT—MODE—◀◀

The initial file mode is A1.

It may be change by specifying the MODE option at invocation, or by issuing the MODE command in the PROFILE macro.

### REXX Variables Set

**MODE** The current file mode

---

## MODULES

Returns information about the modules defined to IDF.

▶▶—EXTRACT—MODULES—◀◀

### REXX Variables Set

**MODULES.0**

Number of modules defined to IDF

**MODULES.n**

Name origin size symbols, where:

**NAME** The name of module.

**ORIGIN** The module's origin in memory, eight digit hexadecimal.

**SIZE** The size of the module origin in bytes, eight digit hexadecimal.

**SYMBOLS** The number of symbols defined to IDF that are associated with this module.

---

## MSTATUS

Returns information about the storage used to contain the extract data information which has been loaded with LANGUAGE LOAD commands. This includes:

- number of compile areas
- extract data storage consumption (total, direct, pooled)
- extract data storage pool utilization, including the number of AREAs in the pool which are unused

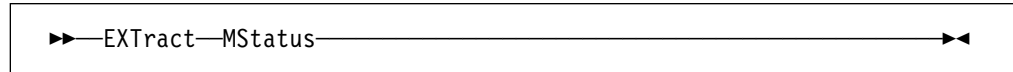

The name of the stemmed variable array defaults to LSM. and may be set by the LANGUAGE STEM command (see “LANGUAGE STEM” on page 130).

The EXLIMIT command (see “EXLIMIT” on page 111) is used to control the maximum stemmed array index value.

### REXX Variables Set

*stemname.0*

Number of items in the stemmed array

*stemname.n*

Information about the extract data storage

---

## NAMES

Returns information about symbol names.

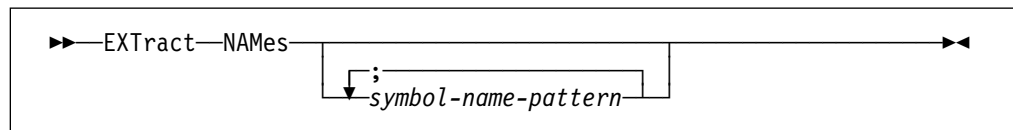

*symbol-name-pattern*

A pattern to match against all the symbol names.

See “NAMES” on page 151 for details about pattern meta-characters. If omitted, all symbol names are returned.

The name of the stemmed variable array defaults to LSM. and may be set by the LANGUAGE STEM command (see “LANGUAGE STEM” on page 130).

The EXLIMIT command (see “EXLIMIT” on page 111) is used to control the maximum stemmed array index value.

### REXX Variables Set

*stemname.0*

Number of items in the stemmed array

*stemname.n*

Information about the symbol names

---

## OPTIONS

Returns a list of all IDF options and their current settings.

```
▶▶—EXTRACT—OPTIONS—◀◀
```

### REXX Variables Set

**OPTION** List of options and their current settings

The contents of variable OPTION have the following format:

CMDLOG=0 COMMAND=0 ... and so on

A value of 1 indicates that the option was last set ON; a value of 0 indicates that the option is OFF. For a list of the options which are returned, see "SET OPTION" on page 177. For information about the meaning of the options, see "IDF Invocation" on page 19.

The string "AMODE31=0" or "AMODE31=1" is included in the data returned by EXTRACT OPTIONS. This provides a means for macros to determine the current addressing mode.

---

## PER (CMS only)

Returns the value of the PER setting.

```
▶▶—EXTRACT—PER—◀◀
```

### REXX Variables Set

**PER** Current PER setting:

- Y if active
- N if inactive
- D if unavailable (TSO, CMS/SP without SET ECMODE ON).

---

## PFK

Extracts all current PFK definitions.

```
▶▶—EXTRACT—PFK—◀◀
```

### REXX Variables Set

**PFK.0 - PFK.24**

Current PFK settings

Where:

- Variable PFK.0 contains the assignment of the **ENTER** key.

## EXTRACT commands

- Variables PFK.1 through PFK.24 contain the assignments of **PF1** through **PF24**.

If a PF key is undefined, its setting is returned as an asterisk (\*).

---

## PLIST

Obtains the arguments provided at IDF invocation.

```
▶▶—EXTRACT—PLIST—————▶▶
```

### REXX Variables Set

**PLIST** Arguments passed to IDF at invocation

---

## PLOCATES

Returns information about variables located through a locator (pointer) variable.

```
▶▶—EXTRACT—PLOCATES—↓;locator-variable-name—————▶▶
```

*locator-variable-name*

A locator variable name.

The name of the stemmed variable array defaults to LSM. and may be set by the LANGUAGE STEM command (see “LANGUAGE STEM” on page 130).

The EXLIMIT command (see “EXLIMIT” on page 111) is used to control the maximum stemmed array index value.

### REXX Variables Set

*stemname.0*

Number of items in the stemmed array

*stemname.n*

Information about the located variables

---

## QUALIFY

Extracts the name of the module that is used with some commands and addresses when no explicit module name is specified.

```
▶▶—EXTRACT—QUALIFY—————▶▶
```

**REXX Variables Set****QUALIFY** The currently qualified module.

---

**QUERY SETTING**

Returns the current value of the indicated indicator or option item.

▶▶—EXTRACT—Query— <i>argument</i> —————▶▶
---

*argument*

The name of the indicator or option item. Information is available for:

AMODE	COMMENTS	IMPMACRO	OLDBREAK	SHOW
APROGMSG	COMPACT	INVPSW	OPTIMIZE	STEM
ASCII	DSECTS	LIBE	PACKED	STOPNOP
AUDIT	DCL/DECLARE	MACROS	PADID	STOPSTMT
AUTH	DEBUG	MACROLOG	PASSPGM	SUBSTRING
AUTOLOAD	DETAIL	MAJOR	PATH	SVC97
AUTOSIZE	DMS0	MODE	PATHFILE	SWAP
BIT	ENUM	MODMAP	QWDUMP	SYSTEM
BCX	EXLIMIT	MSGID	RISK	TRACEALL
BOUNDS	FASTPATH	MSGMODE	RLOG	TRANS
BRIEF	FIXED	NEGATIVE	ROWSTYLE	UNFTDUMP
CHAR	FLOAT	NEST	SALIMIT	VSEP
CKSUBCM	FULLQUAL	NOCODE	SAREGS	XPATH
CMDLOG	HEXDISP	NUCEXT	SCDACTIV	ZONED
CMPEXIT	HEXINPUT	OFFSET	SELFNUCX	1ADSTOP

This command eliminates the need to parse release-dependent information returned by EXTRACT OPTIONS or EXTRACT LANGUAGE OPTIONS.

**REXX Variables Set****QUERY.0** Number of items in the stemmed array**QUERY.n** Information about the indicator or option item current value.

---

**REGS**

Extracts the GPRs, FPRs, and PSW in EBCDIC HEX representation.

▶▶—EXTRACT—REGs—————▶▶
------------------------

**REXX Variables Set****GPR.0 - GPR.15**

Current values of GPRs

**OGPR.0 - OGPR.15**

Previous values of GPRs

**FPR.0 - FPR.15**

Current values of FPRs, if available

**OFPR.0 - OFPR.15**

Previous values of FPRs, if available

**PSW**

Current value of PSW

## EXTRACT commands

<b>OPSW</b>	Previous value of PSW
<b>FPC</b>	Floating point control register, if available

---

## REGSTOPS (CMS only)

Returns a list of registers that have been selected for monitoring.

```
▶▶—EXTRACT—REGSTOPS—————▶▶
```

### REXX Variables Set

#### GPR.0 - GPR.15

Each variable is set to either:

- Y** To indicate that the register is being monitored
- N** To indicate that it is not being monitored.

---

## SCOPE

Returns information about a statement scope block.

```
▶▶—EXTRACT—SCOPE—address—————▶▶
```

#### *address*

An IDF address expression. Defines the statement scope block. If omitted, uses the current execution location as determined from the PSW.

The name of the stemmed variable array defaults to LSM. and may be set by the LANGUAGE STEM command (see “LANGUAGE STEM” on page 130).

The EXLIMIT command (see “EXLIMIT” on page 111) is used to control the maximum stemmed array index value.

### REXX Variables Set

#### *stemname.0*

Number of items in the stemmed array

#### *stemname.1*

Scope block start statement number

#### *stemname.2*

Scope block end statement number

#### *stemname.3*

Scope block owner symbol name (if any)

---

## SCRVAR

Returns the contents of the LSM Information window.

```
▶▶—EXTRACT—SCRVAR—————▶▶
```

The name of the stemmed variable array defaults to LSM. and may be set by the LANGUAGE STEM command (see “LANGUAGE STEM” on page 130).

The EXLIMIT command (see “EXLIMIT” on page 111) is used to control the maximum stemmed array index value.

### REXX Variables Set

*stemname.0*

Number of items in the stemmed array

*stemname.n*

Information about the LSM Information window contents.

## SELFNUCX

Returns the current value of the self-load offset.

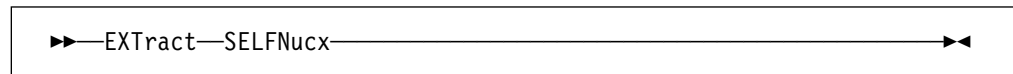

The self-load offset is set by the SELFNUCX symname option at IDF invocation, or by issuing the SET SELFNUCX command.

### REXX Variables Set

**SELFNUCX** Contents are as follows:

- If the program is *not* self-loading, variable SELFNUCX is blank.
- If the self-load offset was specified as a symbol name, the contents of variable SELFNUCX consist of two tokens. The first token is the symbol, and the second is an 8-digit hexadecimal offset.
- If the self-load offset was specified as an absolute value, the contents of variable SELFNUCX consist of two tokens. The first token is the string "<n/a>", and the second token is an 8-digit hexadecimal offset.

## SKIPSTEP

Returns currently skipped subroutines.

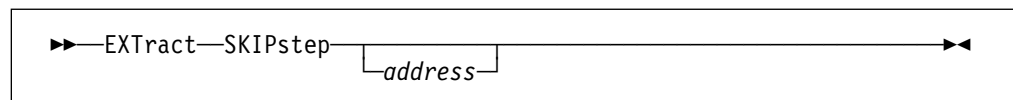

*address*

An IDF expression. Address of subroutine to return. If omitted, all skipped subroutines are returned.

## EXTRACT commands

### REXX Variables Set

**SKIP.0**      Number of subroutines skipped  
**SKIP.n**      The next skipped subroutine

---

## SOURCE

Returns source records.

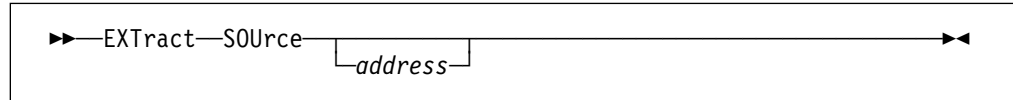

### *address*

The address. May be specified in the form of an IDF address expression. If omitted, uses the current execution location as determined from the PSW.

The name of the stemmed variable array defaults to LSM. and may be set by the LANGUAGE STEM command (see "LANGUAGE STEM" on page 130).

The EXLIMIT command (see "EXLIMIT" on page 111) is used to control the maximum stemmed array index value.

### REXX Variables Set

*stemname.0*

Number of items in the stemmed array

*stemname.n*

The source records for the specified memory address.

---

## STOREMAP

Returns Storage Allocation Map information.

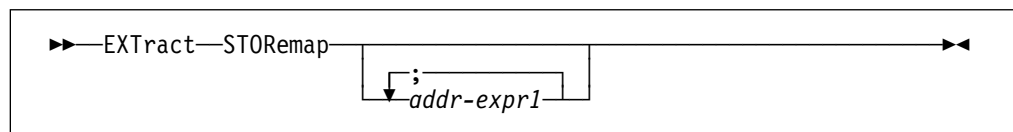

### *addr-expr1*

A storage address expression. If omitted, returns an overall Storage Allocation Map.

The name of the stemmed variable array defaults to LSM. and may be set by the LANGUAGE STEM command (see "LANGUAGE STEM" on page 130).

The EXLIMIT command (see "EXLIMIT" on page 111) is used to control the maximum stemmed array index value.

**REXX Variables Set***stemname.0*

Number of items in the stemmed array

*stemname.n*

Storage Allocation Map information

---

**STRUCTURE**

Returns information about structure or union components.

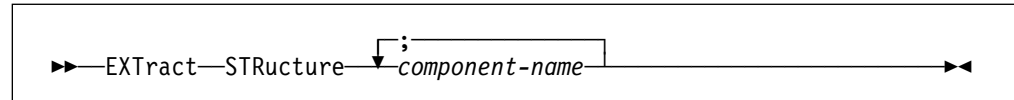
*component-name*

A structure or union component name.

The name of the stemmed variable array defaults to LSM. and may be set by the LANGUAGE STEM command (see “LANGUAGE STEM” on page 130).

The EXLIMIT command (see “EXLIMIT” on page 111) is used to control the maximum stemmed array index value.

**REXX Variables Set***stemname.0*

Number of items in the stemmed array

*stemname.n*

Information about the structure or union components

---

**SVC (CMS only)**

Returns the current SVC tracing state.

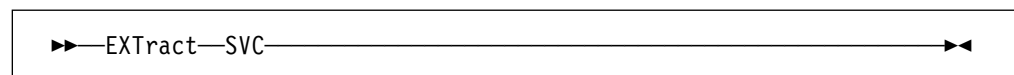
**REXX Variables Set****SVC**

Current SVC tracing state:

**Y** If SVC tracing is in effect**N** If SVC tracing is not in effect.

---

**SYMBOLS**

Returns information about known symbols.

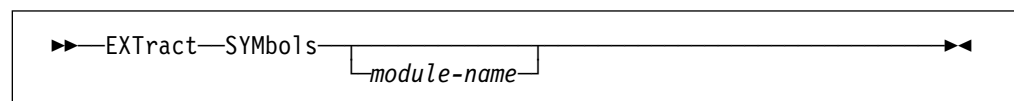

## EXTRACT commands

*module-name*

A module name. Specifies which module's symbols should be returned. If omitted, returns the symbols for the currently qualified module.

### REXX Variables Set

**SYMBOL.0** The number of symbols known to IDF.

Information about individual symbols is returned in SYMBOL.1 to SYMBOL.*nnn*

**SYMBOL.n** Information about one symbol known to IDF.

Each REXX variable containing information about a symbol known to IDF will contain the following information:

(<module.>csect ) symbol reloc addr totlen intext full type

The fields returned have these meanings:

<b>module</b>	The name of the module within which the symbol occurs <ul style="list-style-type: none"><li>• Present if the FULLQUAL option is ON</li><li>• Is followed by a period</li></ul>
<b>csect</b>	The name of the code section within which the symbol occurs.
<b>symbol</b>	The name of the actual symbol.
<b>reloc</b>	The offset of the symbol within the specified CSECT (hex).
<b>addr</b>	The offset of the symbol within the target module (hex).
<b>totlen</b>	The total length associated with the symbol (hex).
<b>intext</b>	One character, either "I" or "E": <ul style="list-style-type: none"><li><b>I</b> means the symbol is an internal symbol</li><li><b>E</b> means the symbol is externally known</li></ul>
<b>full</b>	One character, either "F" or "U": <ul style="list-style-type: none"><li><b>F</b> means the symbol is fully defined.</li><li><b>U</b> means the symbol is not fully defined; this may occur if no information is available to define the start of the CSECT within which the symbol occurs.</li></ul>
<b>type</b>	This is a 2-digit hex value which describes the type of symbol, and is one of: <ul style="list-style-type: none"><li><b>00</b> Space</li><li><b>01</b> CSECT</li><li><b>02</b> DSECT</li><li><b>03</b> COMMON</li><li><b>04</b> Machine Instruction</li><li><b>05</b> CCW</li><li><b>06</b> EQU, LTORG, CNOP, ORG</li><li><b>10</b> C-con</li><li><b>14</b> X-con</li><li><b>18</b> B-con</li><li><b>20</b> F-con</li><li><b>24</b> H-con</li><li><b>28</b> E-con</li><li><b>2C</b> D-con</li><li><b>30</b> A/Q-con</li><li><b>34</b> Y-con</li><li><b>38</b> S-con</li><li><b>3C</b> V-con</li><li><b>40</b> P-con</li><li><b>44</b> Z-con</li></ul>

- 48 L-con
- FE Self-defining, addr is actual value
- FF Unknown, no symbol type available

---

## TASKS

Returns information about the currently executing tasks.

```

▶▶—EXTRACT—TASKS—————▶▶

```

The name of the stemmed variable array defaults to LSM. and may be set by the LANGUAGE STEM command (see “LANGUAGE STEM” on page 130).

The EXLIMIT command (see “EXLIMIT” on page 111) is used to control the maximum stemmed array index value.

### REXX Variables Set

*stemname.0*

Number of items in the stemmed array

*stemname.n*

Task information

---

## TYPE

Returns information about type attributes for variables.

```

▶▶—EXTRACT—TYPE—;—variable-name—————▶▶

```

*variable-name*

A variable names.

The name of the stemmed variable array defaults to LSM. and may be set by the LANGUAGE STEM command (see “LANGUAGE STEM” on page 130).

The EXLIMIT command (see “EXLIMIT” on page 111) is used to control the maximum stemmed array index value.

### REXX Variables Set

*stemname.0*

Number of items in the stemmed array

*stemname.n*

Type information for the specified variables

---

## UNION

A synonym for the command STRUCTURE.

---

## VALUE

Returns the value of an expression.

▶▶—EXTRACT—VALUe—*address*—◀◀

*address*

An IDF address expression.

### REXX Variables Set

**EXPR**           The value of the specified expression

If the address is outside of the programs defined to IDF, the code section (CSECT) name is omitted and the symbolic name is a second hexadecimal value.

If the address is outside the currently qualified module or the FULLQUAL option is ON, then the code section name as defined above is *module.csect*, where *module* is the name of module containing the address.

Numbers in expressions can be specified in explicit (X'123', F'123') or implicit (123) notation. Numbers that do not explicitly specify the base are evaluated according to the current setting of the HEXINPUT option. When writing macros it is recommended that you use explicit base notation.

### Example

```
EXTRACT VALUE ALLOPEN+4(R2)
```

If symbol ALLOPEN was at X'20000' and the target program's R2 contained 8, the value returned would be X'2000C'. This value would be returned in REXX variable EXPR as several tokens, and can be parsed with the following instruction:

```
Parse Var EXPR hexvalue . '(' csect ')' symbolic
```

After this Parse instruction, the following variables would be set:

```
EXPR      0002000C (ALLOPEN) ALLOPEN+12
HEXVALUE  0002000C
CSECT     ALLOPEN
SYMBOLIC  ALLOPEN+12
```

---

## VARIABLE

Returns information about variables.

▶▶—EXTRACT—VARIABLE—*variable-name*—◀◀

*variable-name*

A variable names.

The name of the stemmed variable array defaults to LSM. and may be set by the LANGUAGE STEM command (see “LANGUAGE STEM” on page 130).

The EXLIMIT command (see “EXLIMIT” on page 111) is used to control the maximum stemmed array index value.

### REXX Variables Set

*stemname.0*

Number of items in the stemmed array

*stemname.n*

Information about the variables

---

## VDECLARE | VDCL

Returns attribute information about variables.

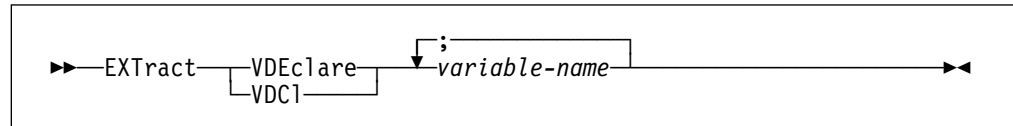

*variable-name*

A variable name.

This command provides information which is independent of display format settings, with the exception of SPACE.

The name of the stemmed variable array defaults to LSM. and may be set by the LANGUAGE STEM command (see “LANGUAGE STEM” on page 130).

The EXLIMIT command (see “EXLIMIT” on page 111) is used to control the maximum stemmed array index value.

### REXX Variables Set

*stemname.0*

Number of items in the stemmed array

*stemname.n*

Attribute information for the specified variables

---

## VERSION

Returns the IDF version information.

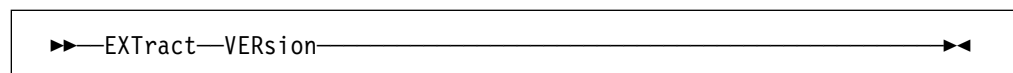

### REXX Variables Set

**VERSION** IDF version information text.

For more information, see “LANGUAGE VERSION” on page 234.

---

## VLOC

Returns location information about the indicated variables.

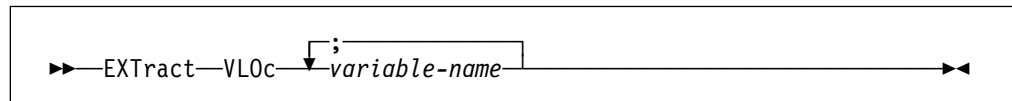

*variable-name*

A variable names.

This command provides information which is independent of display format settings, with the exception of SPACE.

The name of the stemmed variable array defaults to LSM. and may be set by the LANGUAGE STEM command (see “LANGUAGE STEM” on page 130).

The EXLIMIT command (see “EXLIMIT” on page 111) is used to control the maximum stemmed array index value.

### REXX Variables Set

*stemname.0*

Number of items in the stemmed array

*stemname.n*

Location information for the specified variables

---

## VVALUE

Returns data value information about variables.

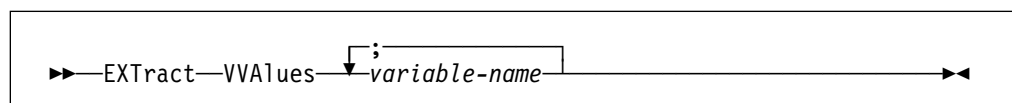

*variable-name*

A variable name.

This command provides information which is independent of the COMPACT and BRIEF settings.

The name of the stemmed variable array defaults to LSM. and may be set by the LANGUAGE STEM command (see “LANGUAGE STEM” on page 130).

The EXLIMIT command (see “EXLIMIT” on page 111) is used to control the maximum stemmed array index value.

**REXX Variables Set***stemname.0*

Number of items in the stemmed array

*stemname.n*

Data value information for the specified variables

---

**WINDOWS**

Returns information about the screen and open windows.

**REXX Variables Set****WINDOW.0** n rows cols

- Where:

**n** The number of windows open on the screen.**rows** The number of rows on the screen that can be filled with windows.**cols** The number of columns on the screen.

- Information about individual windows is returned in variables of the form WINDOW.n.

**WINDOW.n** type orow ocol rows cols start:next

- where:

**type** The type of the open window. It is one of:**ADSTOP** The AdStops window.**AFPR** The Additional Floating-Point Registers window.**BREAK** The Break window.**DISASM** A Disassembly window.**DUMP** A Dump window.**LSMINFO** An LSM Information window.**MINIMIZE** Minimized Windows viewer.**OPTIONS** The Options window.**OREGS** The Old Registers window.**REGS** The Current Registers window.**SKIP** Skipped Subroutines window.**STAT** The Target Status window.**orow** The row on which the upper left corner of the window is located.**ocol** The column on which the upper left corner of the window is located.**rows** The number of rows in the window.**cols** The number of columns in the window.**start** The starting address for storage displayed in the window if it is a Disassembly window or a Dump window.**next** The address of storage to be displayed in the window if it is a Disassembly window or a Dump window and it is scrolled. It is separated from the start address by a colon (:).

---

## Appendix A. ASMLANGX Options

### ASM

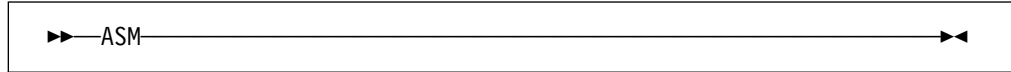

This option indicates that ASM is the language being extracted. Since ASM is the default (and only) language extracted, you need never use this option.

### CONDASM | NOCONDASM

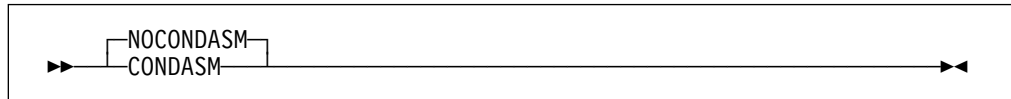

Use CONDASM to include conditional assembly statements and `.*` comments during extraction, NOCONDASM to suppress them.

### DCL | NODCL

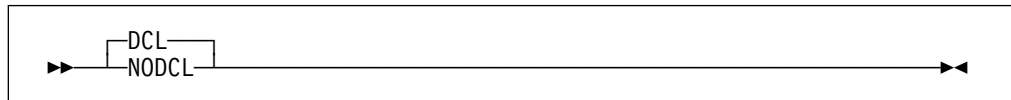

Use DCL to extract source code for declarations, including associated block comments, NODCL to not extract them. (Variable information is extracted regardless.)

### DEBUG

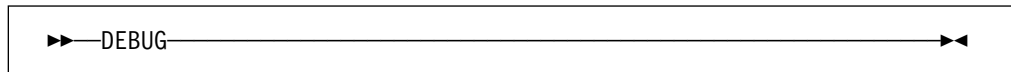

DEBUG is *not* intended for general use. It adds messages to the processing log file. These messages hold internal diagnostic information for IDF Service problem analysis.

### ERROR

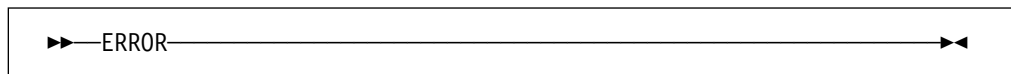

Use ERROR to list variables for which information is incomplete.

## INCL | NOINCL



Use INCL to extract source code for includes, NOINCL to not extract it. (Variable information from included files is extracted regardless.)

## IFM (CMS only)

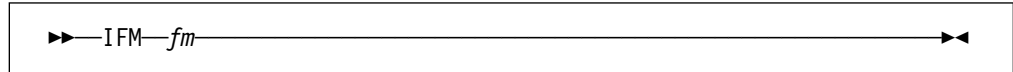

Default: IFM \*

*fm* is the file mode to search initially for all input files, for a non-standard search path. If not found, revert to the standard search path.

## LOUD | QUIET

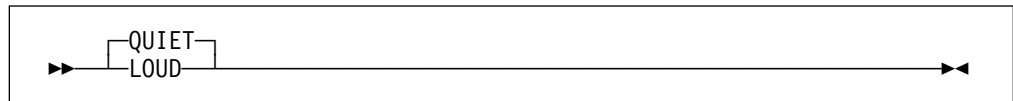

Use LOUD to issue messages to the terminal containing:

- the version and release of ASMLANGX
- the output file identifier
- the input file identifier
- processing progress information

Terminal messages are modified by the execution environment and OS runtime settings:

- On TSO, the messages respect the TSO MSGID setting:
  - MSGID** message identifier and text are displayed
  - NOMSGID** message text is displayed
- On MVS Batch, the messages are written to the JES message log with WT0 ROUTCDE=11. The message identifier and text are shown.
- On CMS, the messages respect the CMS EMSG setting:
  - ON** message identifier and text are displayed
  - TEXT** message text is displayed
  - OFF** message is suppressed
- On VSE Batch, the messages are written to the console log. The message identifier and text are shown.

A header is added to the output file containing:

- the version and release of ASMLANGX
- the input file identifier

Use QUIET to suppress the display of **I** (Informational), **W** (Warning) and **E** (Error) messages. QUIETLY is an alias for QUIET.

## MACDEF | NOMACDEF

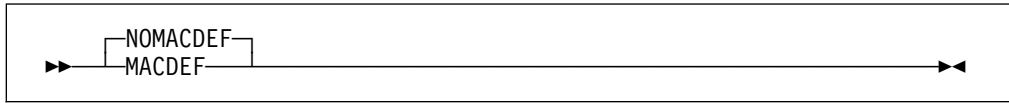

Use MACDEF to include inline macro definitions during extraction, NOMACDEF to suppress them.

## OFM (CMS only)

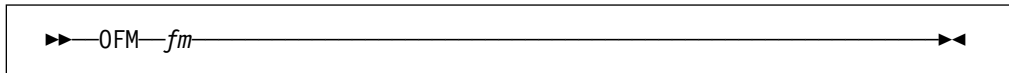

Default: OFM A1

*fm* specifies the file mode (FM) of the output file, if other than the default A1 is desired.

## OFN

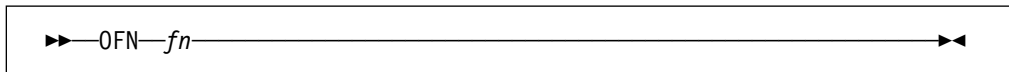

Default: OFN output-file-name

*fn* specifies:

- On TSO, the PDS member name of the output file.
- On CMS, the file name (FN) of the output file.
- On VSE, the librarian member name of the output member.

## OFT

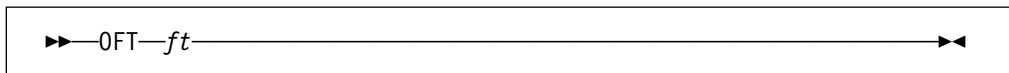

Default: OFT ASMLANGX

*ft* specifies:

- On TSO, the DD name of the output file.
- On CMS, the file type (FT) of the output file.
- On VSE, not used.

## PACK | NOPACK

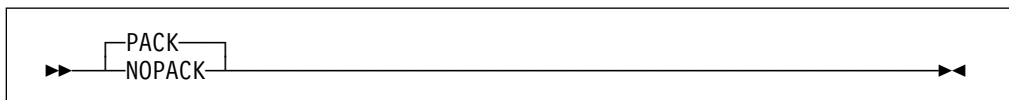

Use PACK to compact redundant characters in source statement text, NOPACK to leave it as is.

## PFM (CMS only)

▶▶—PFM—*fm*————▶▶

Default: PFM \*

*fm* specifies the file mode (FM) to initially search for the input file, if other than the standard search path is desired. If not found, revert to the standard search path. This option overrides the IFM option.

## PFT

▶▶—PFT—*ft*————▶▶

Default: PFT SYSADATA for TSO and CMS, PFT SYSADAT for VSE

*ft* specifies:

- On CMS, the file type (FT) of the input file.
- On TSO, the DD name of the input file.
- On VSE, the DLBL name of the input file.

## SEQ | NOSEQ

▶▶—  
  ┌NOSEQ┐  
  └SEQ  ┘————▶▶

Use SEQ to retain source sequence numbers in columns 73 to 80, NOSEQ to not write them to the extract file. If the PACK option is selected, this significantly reduces the size of a typical extract file.

---

## Appendix B. Diagnostic Messages

---

### Message Numbers and Severity Levels

Each of the messages issued by IDF is of the form:

**Message Format**

**ASMmssnnnnl** text

where:

**ASM** is the component name for IDF and related utilities.

**m** is the program identifier.

This is one of:

**K** ASMLKEDT (VSE Phase MAP Creation Utility)

**L** IDF Language Support

**M** IDF Base Debugger

**X** ASMLANGX (ADATA Extraction Utility)

**ss** is the subsystem identifier.

This identifies the subsystem within the program which issued the message. Its main use is to help IBM Service Personnel in tracking potential problems.

**nnnn** is the message number.

**l** is the message severity level.

This is one of:

**I** Informational message

**A** Action message

Used to prompt for user input

**W** Warning message

**E** Error message

**S** Severe error message

**T** Terminating error message

---

## ASMLKEDT Messages (VSE only)

---

### ASMKxx000W Invalid LNKEDT parameter: *txt1*

**Explanation:** The parameter specified is not a valid LNKEDT parameter.

**User Response:** Correct the parameter to a valid LNKEDT value.

---

### ASMKxx001S No MAP produced

**Explanation:** A MAP file has not been produced.

**User Response:** This message should be accompanied by another error message to explain why this may have occurred.

---

### ASMKxx002S No Librarian DCB generated

**Explanation:** The librarian environment could not be setup to create a MAP.

**User Response:** This is an internal problem. Look for any accompanying messages and if the problem cannot be determined contact your IBM Support Center.

---

### ASMKxx003S OPEN member name: *phasename* failed RC=*retcode*

**Explanation:** A LIBRM OPEN request has failed for the member specified with the return code specified.

**User Response:** See return codes for the LIBRM OPEN macro in the *VSE/ESA System Macro Reference*.

---

### ASMKxx004S PUT member name: *phasename* failed RC=*retcode*

**Explanation:** A LIBRM PUT request has failed for the member specified with the return code specified.

**User Response:** See return codes for the LIBRM PUT macro in the *VSE/ESA System Macro Reference*.

---

### ASMKxx005I Member name: *phasename.MAP* cataloged into sublibrary: *sublib.name*

**Explanation:** Informational message describing the member name and the sublibrary where the member has been cataloged.

**User Response:** None

---

### ASMKxx006S CLOSE member name: *phasename* failed RC=*retcode*

**Explanation:** A LIBRM CLOSE request has failed for the member specified with the return code specified.

**User Response:** See return codes for the LIBRM CLOSE macro in the *VSE/ESA System Macro Reference*.

---

### ASMKxx007S LIBRM STATE for CATALOG library failed RC=*retcode*

**Explanation:** An error has occurred in locating the phase catalog library.

**User Response:** Ensure a // LIBDEF PHASE,CATALOG= statement has been coded. If the statement has been provided then check the return codes for the LIBRM STATE macro in the *VSE/ESA System Macro Reference*.

---

## IDF Language Support Messages

---

### ASMLxx001E Keyword missing

**Explanation:** One or more extra keywords were expected, but were not present.

**User Response:** Change the command specification to add the appropriate keywords.

---

### ASMLxx002E Keyword too long, "*txt1*"

**Explanation:** *txt1* is not recognized as a valid keyword. It exceeds the maximum length of a valid keyword, and may be spelled incorrectly.

**User Response:** Change the command specification to use the appropriate keyword.

---

### ASMLxx003E Keyword not recognized, "*txt1*"

**Explanation:** *txt1* is not recognized as a valid keyword.

**User Response:** Change the command specification to use the appropriate keyword.

---

### ASMLxx004E Keyword not valid in this context, "*txt1*"

**Explanation:** *txt1* is recognized as a valid keyword, but is not valid in the context in which it has been specified.

For example, the command SHOW BOTH is valid, but the command SHOW SHOW will produce this message.

**User Response:** Change the command specification to use the appropriate keyword.

**ASMLxx005E Additional parameters expected**

**Explanation:** One or more extra parameters were expected, but were not present.

**User Response:** Change the command specification to add the appropriate parameters.

**ASMLxx006E Extraneous keyword, "txt1"**

**Explanation:** The keyword *txt1* was specified, but no keyword was expected in this context.

**User Response:** Correct the command specification to eliminate any extraneous keywords.

**ASMLxx010I *txt1*****ASMLxx011I One of: *txt1***

**Explanation:** The "?" keyword was specified in the command, to request command prompting. The list of valid keywords in this context are shown in this message.

**User Response:** Change the command specification to use the appropriate keyword in place of the "?" keyword.

**ASMLxx012I Debug mode is now *txt1***

**Explanation:** A LANGUAGE DEBUG command has been successfully executed. The resulting debug options are shown in this message.

**User Response:** None

**ASMLxx013I *txt1* subsystem not available in this version of *txt2*****ASMLxx020E Unknown color, "txt1"**

**Explanation:** The indicated keyword *txt1* is not recognized as a valid LANGUAGE COLOR keyword.

**User Response:** Change the command specification to use the appropriate keyword.

**ASMLxx030E No Extract data is currently loaded**

**Explanation:** A command has been executed which required that ASMLANGX extract data be previously loaded with LANGUAGE LOAD. None was present, so the command did not complete successfully.

**User Response:** Load the appropriate ASMLANGX extract data files.

**ASMLxx031E Extract file *filename* not LOAded**

**Explanation:** An attempt was made to reference ASMLANGX extract data file *filename*. This file has not yet been loaded with LANGUAGE LOAD.

**User Response:** Load the ASMLANGX extract data file, if required.

**ASMLxx032E Module *txt1* not known to *txt2***

**Explanation:** An attempt was made to reference module *txt1*, which has not been defined to IDF.

**User Response:** Define the module to IDF using the MODULE command.

**ASMLxx033E The PSW indicates an address which is not within any known statement.****ASMLxx034E REXX variable not found: *var1***

**Explanation:** A command has attempted to access the specified REXX variable, but it was not present.

**User Response:** None

**ASMLxx035E Unable to update REXX variable: *var1***

**Explanation:** A command has attempted to update the specified REXX variable, but was unsuccessful.

**User Response:** Ensure sufficient virtual storage is present

**ASMLxx036E Stem ".0" value not positive decimal number: *txt1***

**Explanation:** A command has attempted to access the specified REXX stemmed array variable, but the value of the "stemname.0" control variable was not a positive decimal number.

**User Response:** None

**ASMLxx037E REXX variable data length *dec1* exceeds limit of *dec2* bytes: *var3***

**Explanation:** A command has attempted to access the specified REXX variable, but the contents were too large to fit in the data buffer.

**User Response:** None

**ASMLxx040I Variable separator blank line will be *txt1*****ASMLxx041I Variable location audit will be *txt1*****ASMLxx042I *txt1* variable declaration information will be *txt2*****ASMLxx043I Variable information will be displayed in *txt1* format****ASMLxx050I Structure major component data will be *txt1*****ASMLxx051I LSM window detail level is now "*txt1*, *txt2*"****ASMLxx052E Invalid LSM window detail level, "*txt1*"****ASMLxx053I Structure pad variable names will be *txt1*****ASMLxx060E No Storage Allocation Map information is available**

**Explanation:** A STOREMAP command was executed, but no Storage Allocation Map information was available for display.

**User Response:** None

---

**ASMLxx061E Storage Allocation Map error: *txt1***

**Explanation:** The specified error occurred while building the Storage Allocation Map information display. STOREMAP processing has terminated.

**User Response:** None

---

**ASMLxx065E No Task information is available**

**Explanation:** A TASKS command was executed, but no information about tasks was available for display.

**User Response:** None

---

**ASMLxx066E Task information error: *txt1***

**Explanation:** The specified error occurred while building the Task information display. TASKS processing has terminated.

**User Response:** None

---

**ASMLxx070E No Global Storage stems are currently defined**

**Explanation:** A command has been executed which required that Global Storage stems be defined previously by **SET GLOBAL** commands. None was present, so the command did not complete successfully.

**User Response:** None

---

**ASMLxx072W Global Storage stem not found: *txt1***

**Explanation:** A command has attempted to access the specified Global Storage stem, but it was not defined.

**User Response:** Create the Global Storage stem with the **SET GLOBAL** command.

---

**ASMLxx080I *txt1* checking is now *txt2***

**ASMLxx090I LSM Status/Settings *txt1***

**ASMLxx100E No variable names match pattern: *txt1***

**ASMLxx110E No LongName defined for *txt1* in Module "*txt2*"**

**ASMLxx120I Current *txt1* display format is "*txt2*"**

**ASMLxx121E Unknown *txt1* display format, "*txt2*"**

**ASMLxx122E Display format "*txt1*" not valid for *txt2***

**ASMLxx123E Multiple variables not valid *txt1***

**ASMLxx130I Source at *txt1 txt2* shown**

**ASMLxx131W Unable to perform *txt1* command**

**ASMLxx132E Function not valid if source is suppressed**

**ASMLxx140I Target string displayed at top of DISASM area**

**ASMLxx141W Target not found**

**ASMLxx142E Search not possible, since no source information is available**

**ASMLxx143E Search parameter not recognized: *txt1***

**ASMLxx144E Search string missing or all-blank**

**ASMLxx145E Unexpected characters follow ending delimiter**

**ASMLxx146I Unused extract data memory blocks *txt1***

**ASMLxx147I Unused Global Storage memory blocks *txt1***

**ASMLxx148W Autowrap performed to display target string.**

**ASMLxx150I Display now limited to source code only**

**ASMLxx151I Display of source code disabled**

**ASMLxx152I Interspersed source/disassembly now displayed**

**ASMLxx153I *txt1* will be *txt2***

**ASMLxx154I *txt1* generating code will be shown**

**ASMLxx155I Display reset to show all program information**

**ASMLxx160I LSM window will scroll by *txt1 txt2***

**ASMLxx161I LSM window scrolling disabled**

**ASMLxx162E Invalid LSM window scroll amount, "*txt1*"**

**ASMLxx170I LSM REXX stem variable name is now "*txt1*"**

**ASMLxx171I LSM REXX stem limit is now "*dec1*"**

**ASMLxx172E LSM REXX stem limit *dec1* is outside of range *dec2* to *dec3***

**ASMLxx173E LSM REXX stem index limit reached during EXTRACT**

**ASMLxx180I Maximum Caller level is now *dec1***

**ASMLxx181I CALLERS Save Area registers *txt1***

**ASMLxx182E Caller level *dec1* is outside of range *dec2* to *dec3***

**ASMLxx183E Unable to access Caller level *txt1***

**ASMLxx190I XPATH reset to default value of "*txt1*"**

**ASMLxx191I New XPATH accepted. Review using "LAN OPTIONS"**

**ASMLxx192E Invalid character "*txt1*" in XPATH entry *txt2*. XPATH changes ignored**

**ASMLxx193E Maximum number of XPATH entries (*txt1*) exceeded. XPATH changes ignored**

**ASMLxx200E Var is not *txt1*: *txt2***

**ASMLxx201E Invalid expression syntax: *txt1***

**ASMLxx202E Invalid *txt2* in expression: *txt1***

**ASMLxx203E Missing *txt2* in expression: *txt1***

**ASMLxx204E *txt2* invalid as operand: *txt1***

**ASMLxx205E *txt2* occurred while *txt3* in expression: *txt1***

**ASMLxx206E Expression *txt2* not yet supported: *txt1***

**ASMLxx210E Unknown characters within expression: *txt1***

**ASMLxx211E Extract data is incomplete for: *txt1***

**ASMLxx212E Structure declaration invalid: *txt1***

**ASMLxx213E Array declaration invalid: *txt1***

**ASMLxx214E Internal error processing expression: *txt1***

ASMLxx215E Insufficient free storage to process expression  
ASMLxx220E Error: Var storage at X'*txt1*' not accessible: *txt2*  
ASMLxx221E Automatic storage (DSA) base is R0 - invalid: *txt1*  
ASMLxx222W Warning: Value of *txt1* is *txt2*: *txt3*  
ASMLxx223E Var is a constant but value not extracted: *txt1*  
ASMLxx224W Warning: Bdy(*txt1*) expected for *txt2*: *txt3*  
ASMLxx225W Warning: Optimized var *txt1txt2*  
ASMLxx226E Error: Optimized var *txt1txt2*  
ASMLxx227E Error: Register *txt1* is invalid: *txt2*  
ASMLxx230E No variable name supplied  
ASMLxx231E Variable name exceeds *dec1* chars, or excess data follows variable name  
ASMLxx232E Variable unknown in current compile data: *txt1*  
ASMLxx233E Missing variable name in dot-qualified expression: *txt1*  
ASMLxx234E Ambiguous in current scope; dot-qualify: *txt1*  
ASMLxx235E Not component of indicated structure: *txt1*  
ASMLxx236E Variable unknown in current block: *txt1*  
ASMLxx240E Locating expression required, var is BASED(\*): *txt1*  
ASMLxx241E Var neither based nor part of based structure: *txt1*  
ASMLxx242E Non-pointer specified in locator expression: *txt1*  
ASMLxx243E Pointer name missing from locating expression  
ASMLxx244E Excess locating expressions, maximum allowed is *dec1*  
ASMLxx250E String is not multi-dimensional array: *txt1*  
ASMLxx251W Subscript *txt1* for array dimension *txt2* assumed: *txt3*  
ASMLxx252W Extraneous array subscript *txt1* ignored: *txt2*  
ASMLxx253E Subscripted variable not array or string: *txt1*  
ASMLxx254E Substring valid only for string variables: *txt1*  
ASMLxx255E *txt1 dec2* out of range *dec3* to *dec4* for: *txt5*  
ASMLxx256E Wrap-around substring *dec1:dec2* not allowed: *txt3*  
ASMLxx257E *txt1 dec2* not positive: *txt3*  
ASMLxx258E *txt1 dec2* is below lower bound of *dec3* for: *txt4*  
ASMLxx270E Function argument cannot be evaluated: *txt1*

ASMLxx271E Maximum of *dec2* function argument *txt3* exceeded: *txt1*  
ASMLxx272E Function argument was omitted: *txt1*  
ASMLxx273E Unable to resolve to storage address: *txt1*  
ASMLxx274E Recursive *txt1* ADDR() is not allowed: *txt2*  
ASMLxx300E Read/Only storage at X'*txt1*' - changes ignored, display line *dec2*  
ASMLxx310E All-blank data entered on display line *dec1*  
ASMLxx311E Value entered exceeds maximum allowed by declared precision, display line *dec1*  
ASMLxx312E UnSigned value *txt1* not be negative, display line *dec2*  
ASMLxx313E Length entered exceeds declared string length, display line *dec1*  
ASMLxx320E Non-decimal character entered on display line *dec1*, col *dec2*: *txt3*  
ASMLxx321E Invalid Float syntax detected on display line *dec1*, col *dec2*: *txt3*  
ASMLxx322E Non-hexadecimal character entered on display line *dec1*, col *dec2*: *txt3*  
ASMLxx323E Non-binary character entered on display line *dec1*, col *dec2*: *txt3*  
ASMLxx324E Extraneous bits in last hex character ignored, display line *dec1*  
ASMLxx325E Non-displayable data entered on display line *dec1*, col *dec2*: *txt3*  
ASMLxx326E Non-ASCII character entered on display line *dec1*, col *dec2*: *txt3*  
ASMLxx400E Extra right parenthesis detected  
ASMLxx410E Extract file not found: *txt1*  
ASMLxx411E Extract file DD not allocated: *txt1*  
ASMLxx412E Extract file already LANG LOADED: *txt1*  
ASMLxx413E LongName extract data *txt1* loaded for Module "*txt2*"  
ASMLxx414E Insufficient free storage to LOAD: *txt1*  
ASMLxx420E Extract file version (*txt1*) higher than LSM supports (*txt2*)  
ASMLxx421S Extract file load not successful (RC=*dec1*)  
ASMLxx422E Extract file format invalid: *txt1*  
ASMLxx423E Extract file contains invalid records (RC=*dec1*)  
ASMLxx424E Extract file contains NO supported records  
ASMLxx425E Unable to locate *txt1 txt2* referenced in extract file  
ASMLxx426W Warning: CSECT *txt1* length is X'*txt2*' bytes, X'*txt3*' expected

---

## IDF Base Debugger Messages

---

**ASMMxx001W Operation exception (program check code X'01')**

**ASMMxx002W Privileged operation exception (program check code X'02')**

**ASMMxx003W Execute exception (program check code X'03')**

**ASMMxx004W Protection exception (program check code X'04')**

**ASMMxx005W Addressing exception (program check code X'05')**

**ASMMxx006W Specification exception (program check code X'06')**

**ASMMxx007W Data exception (program check code X'07')**

**ASMMxx008W Fixed-point overflow exception (program check code X'08')**

**ASMMxx009W Fixed-point divide exception (program check code X'09')**

**ASMMxx010W Decimal overflow exception (program check code X'0A')**

**ASMMxx011W Decimal divide exception (program check code X'0B')**

**ASMMxx012W Exponent overflow exception (program check code X'0C')**

**ASMMxx013W Exponent underflow exception (program check code X'0D')**

**ASMMxx014W Significance exception (program check code X'0E')**

**ASMMxx015W Floating-point divide exception (program check code X'0F')**

**Explanation:** IDF received control as a result of the exception which occurred during user program execution.

**User Response:** Determine the cause of the exception, and perform any required corrective action.

The PSW and register values when the exception occurred are available from the Current Registers window.

---

**ASMMxx016W Target program ABENDED; code**

**Explanation:** IDF received control as a result of an ABEND which occurred during user program execution.

**User Response:** Determine the cause of the ABEND, and perform any required corrective action.

More diagnostic information is supplied if available:

- For system ABENDs, the system code value is shown in hexadecimal. If the reason code value is available, it is shown in hexadecimal.
- For user ABENDs, the user code value is shown in decimal. If the reason code value is available, it is shown in decimal.
- For other ABENDs, the ABEND code is shown in decimal.

The PSW and register values when the ABEND occurred are available from the Current Registers window.

---

**ASMMxx017I SVC instruction trapped**

**Explanation:** SVC instruction trapping has been enabled on CMS using the SET SVC Y command, or by changing the SVC setting in the Breakpoint window to "Y".

Subsequently, an SVC instruction has been executed in a user program, and IDF has received control.

**User Response:** None

---

**ASMMxx018I BREAK point has been reached but NOT executed**

**Explanation:** An instruction is about to be executed for which an IDF breakpoint exists. IDF has received control.

**User Response:** None

---

**ASMMxx019I Target program has completed and returned control**

**Explanation:** The initial target program has completed execution. IDF has received control.

**User Response:** None

---

**ASMMxx020W Program exception, code X'xxxx'**

**Explanation:** IDF received control as a result of the exception which occurred during user program execution.

**User Response:** Determine the type and cause of the exception, and perform any required corrective action.

The PSW and register values when the exception occurred are available from the Current Registers window.

---

**ASMMxx021I PER storage alter event by LAST EXECUTED instruction, at *addr***

**Explanation:** IDF received control as a result of the execution of the previous instruction. This instruction had altered a storage location for which an AdStop storage alteration stop range was active.

**User Response:** None

---

**ASMMxx022I PER register alter event by LAST EXECUTED instruction, at *addr***

**Explanation:** IDF received control as a result of the execution of the previous instruction. This instruction had altered a general purpose register (GPR) for which a RegStop register alteration stop was active.

**User Response:** None

---

**ASMMxx023E Requested function is not supported in this environment**

**Explanation:** IDF does not support the requested function in this execution environment.

**User Response:** None

---

**ASMMxx025W Warning: Next instruction is outside of target program's boundaries**

**ASMMxx026W Warning: Can't insert BREAK in R/O storage; IDF may lose control**

**Explanation:** IDF attempted to modify the user program instruction to establish a breakpoint, but was not able to do so as the instruction address is within Read/Only storage.

**User Response:** Establish a suitable breakpoint at an alternate location which can be modified by IDF, and which will be executed as part of the current execution path.

If a suitable alternative location is not available, you must provide a debug execution environment in which this program is in Read/Write storage.

---

**ASMMxx027W No more memory available for PATH function; recording disabled**

**Explanation:** There is insufficient free virtual storage available to allow IDF to record PATH information.

**User Response:** Obtain extra virtual storage.

---

**ASMMxx028E Function not valid when PER is enabled**

**Explanation:** This function is incompatible with the CMS Program Event Recording (PER) feature.

**User Response:** If the function is required, use IDF with PER disabled.

---

**ASMMxx029I Following: *txt1***

**ASMMxx030W FOLLOW address above virtual storage maximum; FOLLOW is now OFF**

**ASMMxx032W Logging of changes to control registers not supported**

**ASMMxx033E IDF initialization failed. Check your environment, or if IDF ABENDED, Logoff, Logon and try again**

**ASMMxx034E IDF is already active**

**ASMMxx035E USER area program not valid in SUBSET mode**

**ASMMxx037E Unable to load target program into user/trans area**

**ASMMxx038E SCBLOCK length value does not match expected value**

**Explanation:** IDF has discovered that its subcommand environment has been damaged. This checking is being performed before executing a REXX exit routine, with the CKSUBCM option specified.

IDF was unable to execute the REXX exit routine for this event, but will try again at the next event.

**User Response:** None.

---

**ASMMxx039E SCBLOCK origin value does not match expected value**

**Explanation:** IDF has discovered that its subcommand environment has been damaged. This checking is being performed before executing a REXX exit routine, with the CKSUBCM option specified.

IDF was unable to execute the REXX exit routine for this event, but will try again at the next event.

**User Response:** None.

---

**ASMMxx040E Nucleus extension is not loaded**

**Explanation:** IDF was invoked with the NUCEXT option, but the target program is not currently present in storage as a CMS Nucleus extension.

IDF processing is terminated.

**User Response:** Use the CMS NUCXLOAD command to load the target program as a CMS Nucleus extension, then invoke IDF.

---

**ASMMxx041E TRANS and NUCEXT options are mutually exclusive**

**Explanation:** IDF was invoked with both the TRANS and NUCEXT options specified. This is not a valid combination.

IDF processing is terminated.

**User Response:** Correct the options specification.

---

**ASMMxx042E NUCEXT specified but file built as transient**

**Explanation:** IDF was invoked with the NUCEXT option specified, but the MODULE file has only one record and is a transient.

IDF processing is terminated.

**User Response:** Correct the options specification.

---

**ASMMxx044E Map origin does not match origin in executable file**

**Explanation:**

**User Response:**

---

**ASMMxx045E MODULE file transient; map/options indicate user**

**Explanation:** IDF was invoked without the TRANS option, but the MODULE file has only one record and is a transient.

IDF processing is terminated.

**User Response:** Correct the options specification.

---

**ASMMxx046E Map/options indicate transient, MODULE file does not**

**Explanation:** IDF was invoked with the TRANS option, but the MODULE file has more than one record and is not a transient.

IDF processing is terminated.

**User Response:** Correct the options specification.

---

**ASMMxx048E Option not recognized or exceeds 8 characters: txt1**

**Explanation:**

**User Response:**

---

**ASMMxx049E No module name specified****ASMMxx050E "txt1" module not found****ASMMxx051E Module name exceeds 8 characters in length****ASMMxx057E COMMAND option specified, but no command was provided****ASMMxx058E Option invalid in this environment: txt1**

**Explanation:** The position of the cursor on the IDF display is not suitable for use as an implicit operand.

**User Response:** Supply an explicit operand, or move the cursor to an acceptable location

---

**ASMMxx060E Unable to load ASMAPOP**

**Explanation:** An error occurred when attempting to load the module ASMAPOP.

**User Response:** Ensure the module ASMAPOP is available to IDF.

---

**ASMMxx061E SELFNUCX specified, but no start symbol provided****ASMMxx062E Start symbol specified on SELFNUCX is not defined: txt1****ASMMxx064E Specified file mode is not valid****ASMMxx065E Not enough free storage; increase virtual memory size and try again****ASMMxx066E Specified PROFILE not found:fn****ASMMxx067E Last option is incomplete****ASMMxx068E Unable to create subcommand environment****ASMMxx069E Unable to load module "txt1" via OS LOAD**

**ASMMxx070E IDF is not supported in this environment; RC=dec1**

**ASMMxx071E Terminal not connected at specified address for txt1; RC=dec2**

**ASMMxx073E Error in screen manager txt1 call; RC=dec2, Diagnostic info: txt3**

**ASMMxx074E Error reading symbol file fn ft; RC=dec2**

**ASMMxx075E Error reading module file fn ft; RC=dec2**

**ASMMxx080E SCBLOCK value: txt1 Expected value: txt2**

**ASMMxx081E SCBLOCK value: txt1 Expected value: txt2 SELFNUCX offset: txt3**

**ASMMxx083E Specified address does not contain a valid instruction**

**ASMMxx084W Main() BREAK adjusted to txt1**

**ASMMxx085E Cursor position not valid for supplying an implicit operand**

**Explanation:** The position of the cursor on the IDF display is not suitable for use as an implicit operand.

**User Response:** Supply an explicit operand, or move the cursor to an acceptable location

---

**ASMMxx087I BREAK set at txt1**

**ASMMxx088I BREAK cleared at txt1**

**ASMMxx089E No BREAK table entries available; clear one and try again**

**ASMMxx090W BREAK already set at txt1**

**ASMMxx091W Warning: Next instruction is a branch-to-here**

**ASMMxx095E No ADSTOP table entries available; clear one and try again**

**ASMMxx096E ADSTOP already set at txt1**

**ASMMxx097E FFFFFFFF is not a valid ADSTOP address**

**ASMMxx098I Start of ADSTOP range dec1 set to txt2**

**ASMMxx100I End of ADSTOP range dec1 set to txt2**

**ASMMxx102E Minimum 22 line screen depth required to run IDF**

**ASMMxx103E SKIPSTEPS may be set from command line or disassembly window only**

**ASMMxx104E No SKIPSTEP table entries available; clear one and try again**

**ASMMxx105I SKIPSTEP set at txt1**

**ASMMxx106I SKIPSTEP cleared at txt1**

**ASMMxx107E Retry count exceeded, txt1 during txt2 operation: txt3**

**ASMMxx108W Segment translation exception (program check code X'10')**

**Explanation:** IDF received control as a result of the exception which occurred during user program execution.

**User Response:** Determine the cause of the exception, and perform any required corrective action.

The PSW and register values when the exception occurred are available from the Current Registers window.

**ASMMxx109W Page translation exception (program check code X'11')**

**Explanation:** IDF received control as a result of the exception which occurred during user program execution.

**User Response:** Determine the cause of the exception, and perform any required corrective action.

The PSW and register values when the exception occurred are available from the Current Registers window.

**ASMMxx112W REPLAY cancelled; terminating as I/O error 99**

**ASMMxx113A Playback ended; press ENTER to continue**

**ASMMxx114E Error reading recorded data; RC=*dec1*; terminating as I/O error 99**

**ASMMxx115E Unknown character entered in *txt1***

**ASMMxx116E Address specified for PSW was not on halfword boundary**

**ASMMxx117E Address specified for PSW was outside of module**

**ASMMxx118E Wait-state and Mode PSW bits may not be changed**

**ASMMxx119E Attempt to modify IDF code; changes discarded from *txt2***

**ASMMxx120E Non-hex character in hex field; changes discarded from *txt2***

**ASMMxx121W Register/PSW display locked out pending execution of startup command**

**ASMMxx126E BREAKs may be cleared on this panel, but not changed**

**Explanation:** An attempt has been made to alter either the address, commands, or conditions associated with a breakpoint or watchpoint using typeover modification on the Break window. The only supported typeover modification is the clearing of a breakpoint by overtyping it with blanks.

**User Response:** Use the BREAK command to alter breakpoint address or command values. Use the WATCH command to alter watchpoint address, command, or condition values.

**ASMMxx127E ADSTOP ranges may be cleared on this panel, but not changed**

**Explanation:** An attempt has been made to alter an AdStop address range using typeover modification on the AdStops window. The only supported typeover modification is the elimination of an AdStop range by overtyping it with blanks.

**User Response:** Use the ADSTOP command to alter the AdStop address range.

**ASMMxx128E RLOG ended because command caused nonzero return code or alarm; RC=*dec1***

**ASMMxx129E Undefined PF/PA key**

**ASMMxx134I Oldest item retrieved; next RETRIEVE will wrap to most recent**

**ASMMxx135E Symbol is undefined**

**ASMMxx136E Symbol is ambiguous; CSECT qualification is required**

**ASMMxx137E Expression contains unknown syntax**

**ASMMxx138E SUBSET is not valid when debugging a transient**

**Explanation:** The SUBSET command is disabled when the target program resides in the CMS transient program area, since the SUBSET command execution would cause the target program storage to be overlaid.

**User Response:** Exit the current IDF debug session before executing the command.

**ASMMxx139I Returned from saved screen image**

**ASMMxx140E No screen image has been saved**

**ASMMxx141E SWAP function is not enabled**

**ASMMxx142A Press QUIT again to return to *txt1***

**Explanation:** IDF protects you from accidentally terminating your debug session by requiring confirmation if the QUIT PF key is pressed.

**User Response:** Press QUIT again to exit IDF, or execute any other command to continue this IDF session.

**ASMMxx143E The exit routine is compiled-code; XEDEXIT is not relevant**

**Explanation:** The CMPEXIT option indicates that the exit routine is a compiled-code routine, not a REXX exit routine. The XEDEXIT command is only used to invoke XEDIT to edit an interpreted REXX exit routine.

**User Response:** Terminate your IDF session and modify your compiled-code exit routine through other means.

---

**ASMMxx144I Storage pointed to by indicated field is now shown**

**Explanation:** The IDF display has been successfully updated to show storage at the address indicated by the cursor.

**User Response:** None

---

**ASMMxx145E No BREAK address specified**

**Explanation:** The breakpoint address value is required, but was not specified.

**User Response:** Specify a breakpoint address expression

---

**ASMMxx146E Non-ASCII character in text field; changes discarded from *txt1***

**Explanation:** The ASCII option is ON, so that the text field uses an ASCII data interpretation. An attempt was made to modify one or more text field characters to values which are not valid ASCII characters. Any modifications of the text field data have been discarded.

**User Response:** Retry using valid ASCII characters, or modify the storage location by typeover of the hexadecimal portion of the DUMP data display

---

**ASMMxx148W Display is at end of virtual storage****ASMMxx149W Display is at location zero****ASMMxx150E Function has no meaning in this display mode****ASMMxx151E Function is not valid while PER is disabled**

**Explanation:** This function requires the CMS Program Event Recording (PER) feature.

**User Response:** If the function is required, enable the IDF PER exploitation using the SET PER Y command, or by changing the PER setting in the Breakpoint window to "Y".

---

**ASMMxx152W PATH option is implied and has been set ON****ASMMxx153I Storage containing the specified data is now shown****ASMMxx154W Specified data does not exist at higher addresses****ASMMxx155W Data not found within target program; repeat to continue search****ASMMxx156E Search argument missing or contains unknown syntax****ASMMxx157E Hexadecimal string must contain even number of digits****ASMMxx158E IDF cannot infer an unambiguous starting location for the search**

**Explanation:** A SEARCH command has been issued without an explicit window specification, or cursor indication of the window at whose start location the search is to begin.

Both Dump and Disassembly windows are open, but each has a different start location. IDF is unable to infer which start address to use in this case.

**User Response:** Specify an explicit window specification or place the cursor in the window with the desired search starting location.

---

**ASMMxx159I Exit exec is now ACTIVE**

**Explanation:** Exit routine processing has been enabled. The exit exec will now receive control when an event occurs.

**User Response:** None

---

**ASMMxx160I Exit exec is now disabled**

**Explanation:** Exit routine processing has been disabled. The exit exec will no longer receive control when an event occurs.

**User Response:** None

---

**ASMMxx161E Command not recognized**

**Explanation:** The keyword is not recognized as a valid command.

**User Response:** Change the command specification to use the appropriate keyword.

---

**ASMMxx162E Missing keyword**

**Explanation:** One or more extra keywords were expected, but were not present.

**User Response:** Change the command specification to add the appropriate keywords.

---

**ASMMxx163E Keyword too long**

**Explanation:** The keyword is not recognized as a valid keyword. It exceeds the maximum length of a valid keyword, and may be spelled incorrectly.

**User Response:** Change the command specification to use the appropriate keyword.

---

**ASMMxx164E Keyword not recognized**

**Explanation:** The keyword is not recognized as a valid keyword.

**User Response:** Change the command specification to use the appropriate keyword.

---

**ASMMxx165E Arguments not recognized**

**Explanation:** One or more arguments were not recognized as valid for this command.

**User Response:** Change the command specification to use the appropriate arguments.

**ASMMxx166E Conditions do not permit successful execution of the given command**

**ASMMxx167W STEP function locked out pending execution of startup command**

**ASMMxx168W Register/PSW display locked out pending execution of startup command**

**ASMMxx169E PFK may not be set to MACRO without macro name**

**ASMMxx172E Address missing or does not contain a valid instruction**

**ASMMxx173I Storage key for address *txt1* is X'*txt2*'**

**ASMMxx176E Specified address *txt1* exceeds virtual storage size *txt2***

**ASMMxx178I Offset reset to *txt1***

**ASMMxx179I Current offset is *txt1***

**ASMMxx180I Instructions executed since last ICOUNT command: *dec1***

**ASMMxx181E Macro not found: *txt1***

**ASMMxx182E SET command RC=*dec1***

**ASMMxx183E Exit macro not found: *txt1***

**ASMMxx185E *txt1* is not supported by the PSWSTEAL command**

**ASMMxx187E Maximum number of PSWSTEALS already set**

**ASMMxx188W PER disabled**

**Explanation:** IDF exploitation of the CMS Program Event Recording (PER) feature has been disabled.

**User Response:** None

**ASMMxx189I PSWSTEAL set at *txt1***

**ASMMxx190E The specified address is in nonexistent or read/only storage**

**ASMMxx191I PSWSTEAL cleared at *txt1***

**ASMMxx192E BREAKs cannot be set within the active copy of IDF**

**ASMMxx193E Replacement PSW is not valid**

**ASMMxx194I IDF interrupt save area is 16 bytes at hex location *txt2***

**ASMMxx195E Wait-state bit may not be set**

**ASMMxx196I *txt1* has been set to *txt2***

**ASMMxx197E No address provided**

**ASMMxx198I Interrupt Save Area modified; breakin recognized**

**ASMMxx199E Macro RC=*dec1***

**ASMMxx200E LOAD RC=*dec1***

**ASMMxx201E RLOG command not allowed while CMDLOG option is set**

**ASMMxx202E Command file "IDF CMDLOG" not found on any disk**

**Explanation:** IDF was invoked with the RLOG parameter, but a log file was not found.

**User Response:** Create a log file before using the RLOG parameter.

**ASMMxx203E Error attempting to read "IDF CMDLOG"; RC=*dec2***

**ASMMxx204I *dec1* commands successfully executed; stopped after first "*txt2*"**

**ASMMxx205I RLOG terminated by normal end-of-file on "IDF CMDLOG"**

**Explanation:** You issued an RLOG command, but there were no more log records on the log file.

**User Response:** None.

**ASMMxx207I Command logging is now active**

**Explanation:** The IDF command logging is now writing commands to the log file.

**User Response:** None.

**ASMMxx208E "Old" data does not match the specified value**

**ASMMxx209E Hex data contains odd number of digits or invalid hex digit**

**ASMMxx210E Missing "/", type not X/C, or mismatching field sizes**

**ASMMxx211E Function is only valid when PATH option is on**

**ASMMxx212E No history available yet**

**ASMMxx213W No more history information available in that direction**

**ASMMxx214E PER bit in PSW may not be changed; when PER=Y, IDF controls PER**

**ASMMxx215E Attempt to access or modify nonexistent or read/only storage**

**ASMMxx216E WATCH comparator not one of: *txt1***

**ASMMxx217E WATCH instruction missing / not one of: *txt1***

**ASMMxx218E WATCH instruction operands are missing**

**ASMMxx219I WATCH condition: *txt1***

**ASMMxx221W Warning: WATCH operand address is not valid; unable to evaluate**

**ASMMxx222E Second operand has incorrect length for the specified opcode**

**ASMMxx223E Specified window number is invalid**

**ASMMxx224E Specified window number is not the right type for the command**

**ASMMxx225E No more windows can be opened**

**ASMMxx226E Window type invalid for OPEN**

**ASMMxx227W Attention interrupt trapped**

**ASMMxx228I Extract file automatically loaded for CSECT *txt1***

**ASMMxx229S IDF *txt2* support component failed to initialize; RC=*dec2***

**Explanation:** This message indicates that a required component failed initialization.

**User Response:** Ensure invocation parameters are correctly specified, or determine reason for failure (eg, check the system log for accompanying messages). If an accompanying message IFA104I is issued, please refer to *OS/390 Planning for Installation GC28-1726* for product enablement.

---

**ASMMxx237E No module name specified**  
**ASMMxx238E Module name too long**  
**ASMMxx239E Macro name too long**  
**ASMMxx241E Module name not valid**  
**ASMMxx242E Option value must be ON or OFF or cleared**  
**ASMMxx243E A Deferred BREAK for module *txt1* failed to install; RC=*dec2***  
**ASMMxx245I Deferred BREAK set at *txt1***  
**ASMMxx246I Deferred BREAK cleared at *txt1***  
**ASMMxx247W Deferred BREAK already set for *txt1***  
**ASMMxx248I Module *txt1* loaded and Deferred BREAKs installed**  
**ASMMxx250E Deferred BREAKs must be set by the DBREAK command**  
**ASMMxx252E SVC 97 used; only the address and ASC bits of PSW may be modified**  
**ASMMxx253E PROGCK supports only decimal codes 1 through 15**  
**ASMMxx254E Invalid number**  
**ASMMxx255E Language support window not open**  
**ASMMxx256E Extraneous parameters**

**Explanation:** One or more extraneous parameters was encountered during processing of the IDF invocation parameters.

IDF processing is terminated.

**User Response:** Correct the invocation parameters specification.

---

**ASMMxx257W Target program check (code X '*txt1*'); intercepted by ESPIE**  
**ASMMxx262W Program apparently self-modifying; IDF BREAK instruction overlaid**  
**ASMMxx264E Target program not yet loaded; command rejected**  
**ASMMxx265E Too late for "*txt1*" command**

**Explanation:** The command cannot be requested after IDF has started.

**User Response:** Include the command as an invocation parameter, or in the PROFILE macro.

---

**ASMMxx266E Conflicting options specified**  
**ASMMxx272I Value is *txt1***

---

## ADATA Extraction Utility Messages

---

### ASMXXx001I ASMLANGX Version 1 (Release 3)

**Explanation:** This message shows the ASMLANGX program identification, version, and release date.

This message, as well as most other ASMLANGX messages, is normally only displayed if the ASMLANGX LOUD option is specified.

**User Response:** None

---

### ASMXXx002I Output file: *fn ft fm*

**Explanation:** This message identifies the file to which the extract data information will be written by ASMLANGX.

- On CMS, this is a standard CMS file identifier
- On MVS, this is mapped as follows:

CMS	Equivalent on TSO
<i>fn</i>	PDS member name (ignored if using sequential file)
<i>ft</i>	DDNAME, which in turn points to the TSO data set name
<i>fm</i>	not used on TSO

**User Response:** None

---

### ASMXXx003I ... scanning *txt1*

**Explanation:** This message indicates that the information specified in *txt1* is being read from the associated file and processed.

**User Response:** None

---

### ASMXXx004I ... checking *txt1*

**Explanation:** This message indicates that the information specified in *txt1* is checked for consistency.

**User Response:** None

---

### ASMXXx005I *txt1* Pass *dec2* processing begins

**Explanation:** This message indicates pass **dec2** of the multi-pass processing task specified in *txt1* is now being performed.

**User Response:** None

---

**ASMxxx006I Post-processing begins**

**Explanation:** This message indicates that all the needed information has been read from the associated files, and post-processing of this information is being performed.

**User Response:** None

---

**ASMxxx007I ... matching *txt1***

**Explanation:** This message indicates that the information specified in *txt1* is now being correlated.

**User Response:** None

---

**ASMxxx008I ... performing *txt1***

**Explanation:** This message indicates that the processing step specified in *txt1* is now being performed.

**User Response:** None

---

**ASMxxx010I *txt1* records scanned: *dec2***

**Explanation:** This message indicates that *dec2* records were read from the *txt1* file when the current compile unit was processed by ASMLANGX.

**User Response:** None

---

**ASMxxx011I ...Symbols *txt1.. dec2***

**Explanation:** This message indicates that the current compile unit contained *dec2* symbols with characteristics of type *txt1*

**User Response:** None

---

**ASMxxx013I ...Total symbols: *dec1***

**Explanation:** This message indicates that the current compile unit contained *dec1* symbols.

**User Response:** None

---

**ASMxxx014I Records written to output file: *dec1***

**Explanation:** This message shows the number of records of extract data information which were written to the output file.

**User Response:** None

---

**ASMxxx015I Operation completed for this compile unit**

**Explanation:** Processing has completed for the current compile unit. If more compile units are present, processing continues.

**User Response:** None

---



---

**ASMxxx016I *txt1 txt2***

**Explanation:** This message identifies the input files which were processed by ASMLANGX

The *txt1* field is normally "Input file:" or "Input files:".

See the explanation for message ASMxxx002I for a full description of the *txt2* information.

**User Response:** None

---

**ASMxxx017I Operation completed for this extract file**

**Explanation:** This is the last message to be displayed by ASMLANGX, and indicates that processing has completed for this ASMLANGX extract data file.

**User Response:** None

---

**ASMxxx018I *txt1* bytes scanned: *dec2***

**Explanation:** This message indicates that *dec2* bytes of data were read from the *txt1* file when the current compile unit was processed by ASMLANGX.

**User Response:** None

---

**ASMxxx050W Argument missing for *txt1* option. *txt2***

**Explanation:** The argument for ASMLANGX option *txt1* was not found during processing of the ASMLANGX invocation parameters.

The default argument for the *txt1* option is assumed.

**User Response:** Specify the missing argument, or remove the option from the invocation parameters.

---

**ASMxxx051S Argument/Option too long, "*txt1*"**

**Explanation:** The invocation parameter *txt1* is not recognized as a valid ASMLANGX argument (or option). It exceeds the maximum length of a valid argument (or option), and may be spelled incorrectly.

ASMLANGX processing is terminated.

**User Response:** Correct the invocation parameter.

---

**ASMxxx052S Argument/Option not recognized, "*txt1*"**

**Explanation:** The invocation parameter *txt1* is not recognized as a valid ASMLANGX argument (or option).

ASMLANGX processing is terminated.

**User Response:** Correct the invocation parameter.

---

---

**ASMXxx054S File mode is too long, "txt1"**

**Explanation:** The CMS file mode specification *txt1*, which is longer than 2 characters, was encountered during processing of the ASMLANGX invocation parameters.

ASMLANGX processing is terminated.

**User Response:** Correct the file mode specification.

---

**ASMXxx055S A left parenthesis was found inside options**

**Explanation:** An extra left parenthesis, after the initial left parenthesis which signals the start of the ASMLANGX options, was encountered during processing of the ASMLANGX invocation parameters.

ASMLANGX processing is terminated.

**User Response:** Correct the options specification.

---

**ASMXxx056S No file name was specified**

**Explanation:** The file name (on CMS, PDS member name on TSO) of the primary program information file from which source and variable data is to be extracted was not found during processing of the ASMLANGX invocation parameters.

ASMLANGX processing is terminated.

**User Response:** Specify the name of the primary program information file.

---

**ASMXxx057S Argument/Option already specified, "txt1"**

**Explanation:** The argument (or option) *txt1* has been encountered more than once during processing of the ASMLANGX invocation parameters.

ASMLANGX processing is terminated.

**User Response:** Remove the duplicate argument (or option).

---

**ASMXxx058S Argument/Option "txt1" conflicts with previous Argument/Option**

**Explanation:** A conflict between the argument (or option) *txt1* and another previously specified argument (or option) has been detected during processing of the ASMLANGX invocation parameters.

ASMLANGX processing is terminated.

**User Response:** Remove the conflicting argument (or option).

---

**ASMXxx059I Application language not specified, option "txt1" assumed**

**Explanation:** In the absence of an ASMLANGX option which explicitly specifies the application programming language, the ASMLANGX option *txt1* was assumed.

ASMLANGX processing continues.

**User Response:** Specify the application language, using the appropriate ASMLANGX option.

---

**ASMXxx100S *txt1* contains NO recognized records**  
**ASMXxx101W Warning - *txt1* file newer than *txt2* file**  
**ASMXxx102T *txt1* file has more *txt2* than *txt3* file**  
**ASMXxx103S *txt1* has unrecognized records following last valid section**

**ASMXxx104W** Expected: *dec1*, actual: *dec2* at line *dec3*

**ASMXxx105W ...Symbols *txt1*.. *dec2***

**ASMXxx111S** *txt1* not supported - fatal

**ASMXxx114S** *txt1* required for source support - fatal

**ASMXxx115W** *txt1* required for symbol support

**ASMXxx116W** *txt1* required for structure/union support

**ASMXxx120W *txt1* detected. *txt2* option assumed**

**Explanation:** The format of the input file indicates that the specified option is no longer in effect.

ASMLANGX processing continues, assuming an appropriate option to match the format of the input file.

**User Response:** Use the correct compiler option, or make the compiler directive which adjusted the compiler option visible to ASMLANGX, as appropriate.

---

**ASMXxx130S File not found "txt1"**

**Explanation:** The ASMLANGX extract data file *txt1* could not be found to allow ASMLANGX processing to begin.

ASMLANGX processing is terminated.

**User Response:** Correct the file specification, or make the file available to ASMLANGX, as appropriate.

---

**ASMXxx131S Files not found "txt1", and "txt2"**

**Explanation:** The ASMLANGX extract data file could not be found using either the primary file identifier *txt1*, or the alternative file identifier *txt2* to allow ASMLANGX processing to begin.

ASMLANGX processing is terminated.

**User Response:** Correct the file specification, or make the file available to ASMLANGX, as appropriate.

---

---

**ASMxxx132S Input or Output file format invalid**

**Explanation:** The attributes or contents of a file have been found to be inappropriate, during ASMLANGX processing.

One or more preceding messages will identify the file which was being processed when the error occurred.

ASMLANGX processing is terminated.

**User Response:** Correct the problem identified in the preceding message.

---

**ASMxxx133S File DD not allocated "txt1"**

**Explanation:** The Data Definition (DD) for the *txt1* file was found to be unallocated.

ASMLANGX processing is terminated.

**User Response:** Allocate the file, using a JCL DD statement, or TSO ALLOCATE statement, as appropriate.

---

**ASMxxx134S File DDs not allocated "txt1", and "txt2"**

**Explanation:** The Data Definitions (DDs) for the both the primary *txt1* file and the alternative *txt2* file were found to be unallocated.

ASMLANGX processing is terminated.

**User Response:** Allocate the file, using a JCL DD statement, or TSO ALLOCATE statement, as appropriate.

---

**ASMxxx135S txt1 file incorrectly defined**

**Explanation:** The attributes of the *txt1* file have been examined, and found to be inappropriate.

ASMLANGX processing is terminated.

**User Response:** Ensure that the correct data set has been specified in the *txt1* file allocation. If the correct data set was specified, the data set has been allocated with incorrect attributes, in which case it must be reallocated.

---

**ASMxxx136S Premature txt1 End-of-File encountered**

**Explanation:** ASMLANGX had begun scanning the *txt1* file data, but the file ended before all expected data records had been scanned.

ASMLANGX processing is terminated.

**User Response:** Ensure that the correct data set has been specified in the *txt1* file allocation. If the correct data set was specified, the file may have been truncated and must be replaced with the complete data.

---

**ASMxxx137S txt1 disk/directory is full**

**Explanation:** There is insufficient space to write further records to the *txt1* file.

- On CMS, this may be caused by:
  - minidisk free space being exhausted
- On MVS, this may be caused by:
  - PDS directory having no free entries
  - data set having maximum number of extents
  - insufficient free space on the DASD volume for another extent
- On VSE, this may be caused by:

ASMLANGX processing is terminated.

**User Response:** Determine the resource which has been exhausted, and correct as appropriate.

---

**ASMxxx138T Insufficient virtual memory available**

**Explanation:** There is insufficient free storage for ASMLANGX to continue processing.

ASMLANGX processing is terminated.

**User Response:** Free up virtual storage which is currently in use, or make more virtual storage available, as appropriate.

ASMLANGX exploits storage above the 16MB line, if it is available.

---

**ASMxxx139S File is TERSEd or PACKed "txt1"**

**Explanation:** The specified file was found to have a Fixed record format, and 1024-byte record length. It was likely compressed using TERSE or COPYFILE.

ASMLANGX processing is terminated.

**User Response:** Restore the file to its original format, using the appropriate utility program.

---

**ASMxxx150T Maximum number of symbols exceeded**

**Explanation:** The maximum number of symbols that a single compile unit can contain is 65534. This limit is exceeded by the current compile unit.

ASMLANGX processing is terminated.

**User Response:** Reduce the number of symbols below the limit.

---

**ASMxxx151T Extract information not available for symbol dec1**

**Explanation:**

**User Response:**

---

**ASMxxx152W Incomplete information for symbol  
"txt1" (ident: dec2)**

**Explanation:** During the extraction process, complete information was not available for the symbol shown. The extract data for unrelated symbols and program source is not affected.

ASMLANGX processing continues.

---

**ASMxxx153W Declared at line dec1,  
stmt dec2**

**Explanation:** This message is associated with ASMxxx152W, and provides more information to allow the symbol to be easily identified.

**User Response:** None

---

**ASMxxx154W Unknown txt1 txt2 token, "txt3" at line  
dec4 of txt5**

**ASMxxx155W Member txt1 dot qualification invalid  
at line dec2 of txt3**

**ASMxxx156W Incomplete txt1 information detected  
at line dec2 of txt3**

**ASMxxx157W No ESD entry for external definition  
"txt1"**

**ASMxxx159W Pseudo-Assembly synchronization  
error at line dec1 of txt2**

**ASMxxx160W Unable to locate txt1 for label "txt2"**

**ASMxxx161W txt1 ignored at line dec2 of txt3**

**ASMxxx162W - check for txt1 suppression via txt2**

**ASMxxx163W Possible candidate  
procedure/functions:**

**ASMxxx164W - name: txt1**

**ASMxxx165W defined at txt1 (txt2)**

**ASMxxx166W cross reference entry at line dec1 of  
listing**

**ASMxxx167W Within dead code, txt1**

**ASMxxx168W txt1 attribute conflict for symbol "txt2"  
(ident: dec3)**

**ASMxxx200W txt1. Contact IBM Support Center**

**ASMxxx201T txt1 is terminated. Contact IBM  
Support Center**

**ASMxxx210S Extraction for txt1 is not supported (by  
this version of txt2)**

**ASMxxx211W Extraction for your release of txt1 is  
not supported (by this version of txt2)**

**ASMxxx212W The txt1 which produced txt2 could  
not be identified**

**ASMxxx213W Verify that mandatory txt1  
maintenance has been applied**

**ASMxxx214S txt1 error messages detected at record  
dec2 of txt3**

**ASMxxx220W txt1 overflowed**

**ASMxxx221W txt1 overflowed at record dec2 of txt3**

**ASMxxx222W txt1 encountered at record dec2 of txt3**

**ASMxxx223W txt1 encountered for stmt dec2 at  
record dec3 of txt4**

**ASMxxx224W txt1dec2 encountered for stmt dec3 at  
record dec4 of txt5**

**ASMxxx225W txt1 txt2 encountered at record dec3 of  
txt4**

**ASMxxx226W txt1 dec2 mismatch at record dec3 of  
txt4**

**ASMxxx228W Alias missing, id=dec1**

**ASMxxx229W No txt1 were detected**

**ASMxxx231S Missing txt1 ESD information**

**ASMxxx232S Unable to determine location of  
program code/data**

**ASMxxx233S Unable to determine identity of  
unnamed PC Section**

**ASMxxx235W The DSA base reg txt1 is not defined  
to txt2**

**ASMxxx240S txt1 extraction is only supported for  
txt2**

**ASMxxx241S For txt1, enable the txt2 "txt3" option  
ASMxxx242S and make the txt1 file available to  
ASMLANGX**

## Appendix C. Abbreviations

The following list shows the minimum abbreviation for all IDF keywords in UPPER case. Keywords added or changed in this version are flagged with an asterisk:

\$\$	CMDMsg	LSM	PATH	R5
\$WHERE	CMPEXIT	LSMDebug	PATHFile	R6
?	COLors	LSMProf	PAUSe	R7
=	COMmand	LUtype	PER	R8
ABEND	CREGs	MACro	PFK	R9
ADStops	CURsor	MACROLog	PFKDisp	SBORDER
AFPR	DFLTLsm	MODE	PLIST	SCDactiv
ALArm	DISasm	MODMap	Previous	SELFNucx
ALet	DMS0	MODUles	PROfile	SET
AMODE24	DROp	MOVE	PROGck	SIZE
AMODE31	DUMP	MRUn	PSW	SKIPstep
AREGS	DUMPMode	MSG	PSWSTEAL	STATus
ARGument	EPOffset	MSG1	QUALify	STAY
AR0	EVEnt	MSG2	QUIT	STEP
AR1	EXItexec	MSTep	QWDump	STMTstep
AR10	EXTRact	Next	RCQuit	STOKey
AR11	FASTPath	NLS	REFresh	STOPNOP
AR12	FINd	NOAUTOLd	REGs	STOPSTmt
AR13	FOLLOW	NOAUTOSz	REGSTops	STRucture
AR14	FPC	NOBcx	RETRieve	SUBset
AR15	FPR	NODSects	RiGht	SVC
AR2	FULLQual	NOIMPMac	RISk	SVC97
AR3	GLObal	NOINVPsw	RLog	SWAp
AR4	GPR	NOMODMap	ROWstyle	SYMBols
AR5	HEXDisp	NOPROfil	RUN	SYStem
AR6	HEXInput	NOSTOPNp	RUNExit	TRACeall
AR7	HISTory	NOSTOPSt	R0	TRANs
AR8	ICount	NOSVC97	R1	UNFtdump
AR9	IMPMacro	NUCext	R10	UNTIl
ASCii	INVPsw	OFF	R11	VALue
AUTOLoad	ISA	OFFSet	R12	VARiable
AUTOSize	KWDSYN	OLDBREAK	R13	VChangE
BACK	LANguage	ON	R14	VERsion
BASE	LASTmsg	OPCODE	R15	VS
BCX	LEft	OPEn	R2	WATch
BREak	LIBE	OPTion	R3	WINDows
CDE	LIKE	OPTions	R4	XEDexit
CKSubcm	LINE	ORDer		1ADStop
CLOse	LOAd	OREGs		
CMDLog	LOCATIon	PASspgm		

**Note:** The following keywords are used for maintenance commands and can therefore not be used as macro names: \$WHERE, \$\$.

---

## Appendix D. Performance Considerations

When IDF displays an area of memory, in either disassemble or dump format, the screen display is created dynamically, but a page-forward operation should occur at essentially the data transfer rate of the terminal.

If statement source is being displayed, the actual source text is obtained dynamically from the IDF Language extract data file. The extra overhead compared to pure disassembly is minimized by the design of the IDF Language Support.

Some delays may be noticed on heavily loaded systems, but these are generally in the nature of scheduling delays, where IDF is waiting its turn at the processor.

There is a general belief that using PER will cause a serious system-wide performance impact. When using CP PER this belief is probably well justified, since there is significant processing for any instruction that modifies storage, because CP performs a partial disassembly to determine where storage was modified. Since this processing is happening on the CP level it can seriously affect performance on a system-wide basis.

When IDF is used for a similar function, there should be no significant system-wide performance penalty above that imposed by any processor-bound application. Instead of disassembling instructions, CP needs only to report an interrupt to the virtual machine in which IDF is operating.

When the PATH option is OFF, the target program runs at what amounts to full speed between breakpoints. When the PATH option is ON, IDF causes an interrupt following every target program instruction.

Overhead per breakpoint varies in the approximate range of 300-500 IDF instructions per breakpoint. This includes prioritized breakpoint insertion, target activation, interrupt occurrence, event recognition, and saving the target program's state. The variation is as follows, with the first item shown being the least costly and the last item shown being the most costly:

1. PER OFF, PATH OFF
2. PER ON, PATH OFF
3. PER OFF, PATH ON
4. PER ON, PATH ON

Even though the PATH option can be relatively costly in terms of processor usage, it is extremely useful both for collecting code coverage information and for "back-tracking" by means of the HISTORY command.

Exit routines should also be used with some caution, since a REXX exec is executed each time a breakpoint event occurs.

When the list of subroutines to be skipped when single-stepping, statement stepping, or running with PATH or FASTPATH active is not empty there is more overhead on every "subroutine call instruction" (for example, BALR, BAL, BASSM) that is executed. There is a binary search of the list of subroutines to be skipped to determine if the subroutine being called is supposed to be skipped.

---

## Appendix E. Migrating from TSO/E TEST to IDF

This section describes some considerations for those users of IDF who are migrating from a debug setup which used the TSO/E TEST debugger.

### General Considerations

TSO/E TEST and IDF have very different command syntaxes. This section does not provide a detailed comparison of the two command sets. However, procedures are described to perform operations equivalent to those under TSO/E TEST.

The expression syntaxes are somewhat different. Instead of TSO/E TEST's "modname.csect.address" IDF uses "(modname.csect)address". The CSECT name may be omitted if the address is unique within the module. The module name may be omitted, if the address is in the qualified module, which is set by the QUALIFY command. For register specifications in expressions IDF uses "n(Rn)" instead of TSO/E TEST's "nR%+n". IDF supports the same "%" and "?" indirection operators as TSO/E TEST. However, the first indirection operator following a register specification is used to determine the size of the address in the register. For more details on expressions in IDF see "Address Expressions" on page 73.

Some significant advantages of IDF over TSO/E TEST are:

- IDF is a full screen debugger
- IDF can single-step
- IDF is easy to customize through its REXX macro capabilities.
- IDF has a sophisticated cursor addressing support which minimizes the amount of typing you have to do. For more details see "Intelligent Cursor Sensing" on page 4.

TSO/E TEST does have some advantages over IDF:

- TSO/E TEST has automatic symbol support for all load modules loaded.

ASMIDF provides the following alternatives:

- For dynamically loaded modules, the IDF DBREAK command should be used. When the module is fetched into storage, IDF *will* automatically load symbols.
- The process of manually identifying extra modules in storage to IDF and loading symbols requires only two commands: MODULE CDE and LOAD SYMBOLS.

### Invoking the target program

Properly invoking IDF can easily get you breakpoints in modules that get loaded by another. For example, if you wanted to debug the program XYZZY that runs as an ISPF dialog, using TSO TEST you would:

```
TEST 'SYS1.ISP.LINKLIB(ISPF)' CP
ISPSTART PGM(XYZZY)
AT XYZZY.XYZZY.+0 DEFER
```

Figure 25. Invoking an ISPF dialog using TSO TEST

While using ASMIDF you would:

```
ASMIDF XYZZY (COMMAND/ISPSTART PGM(XYZZY)
once in IDF,
BREAK (XYZZY)
```

*Figure 26. Invoking an ISPF dialog using IDF*

This can only be done if you are using SVC 97 for breakpoints.

## Specifying the target program parameters

As shown in the example above, another difference between IDF and TSO/E TEST is in the debugging of TSO command processors. With TSO/E TEST adding the option CP to the TEST command tells TSO/E TEST that the program being debugged is a TSO command processor. TSO/E TEST then prompts you for the command to be passed to the target in the form of a Command Processor Parameter List (CPPL). Under IDF, the COMMAND option instructs IDF that the parameter string is not a parameter for the target but is a command that should be executed when the target is first started (with the RUN or MRUN commands). If the command being executed is the target program, then you can debug a TSO command which is passed a CPPL. A few examples may help illustrate this:

1. If you wanted to debug a REXX/TSO function package, RXLOCFN in this case.

Using TSO TEST you would:

```
TEST 'SYS1.LINKLIB(REXX)' CP
EXEC REXTRY
AT RXLOCFN.RXLOCFN.+0 DEFER
```

While using IDF you would:

```
ASMIDF RXLOCFN (COMMAND/EXEC REXTRY
once in IDF, BREAK (RXLOCFN).
```

In this example IDF is not passing control to RXLOCFN but to EXEC and the parameter string that is passed as a CPPL is for EXEC.

2. If you wanted to debug a command processor, INVOKE in this case.

Using TSO TEST you would:

```
TEST LOAD(INVOKE) CP
INVOKE IEBGENER
```

While using IDF you would:

```
ASMIDF INVOKE (COMMAND/INVOKE IEBGENER
```

In this example IDF is passing control to INVOKE and the parameter string that is passed as a CPPL is for INVOKE.

---

# Notices

This information was developed for products and services offered in the U.S.A.

IBM may not offer the products, services, or features discussed in this document in other countries. Consult your local IBM representative for information on the products and services currently available in your area. Any reference to an IBM product, program, or service is not intended to state or imply that only that IBM product, program, or service may be used. Any functionally equivalent product, program, or service that does not infringe any IBM intellectual property right may be used instead. However, it is the user's responsibility to evaluate and verify the operation of any non-IBM product, program, or service.

IBM may have patents or pending patent applications covering subject matter described in this document. The furnishing of this document does not give you any license to these patents. You can send license inquiries, in writing, to:

IBM Director of Licensing  
IBM Corporation  
North Castle Drive  
Armonk, NY 10504-1785  
U.S.A.

Licensees of this program who wish to have information about it for the purpose of enabling: (i) the exchange of information between independently created programs and other programs (including this one) and (ii) the mutual use of the information which has been exchanged, should contact:

IBM Corporation  
Mail Station P300  
522 South Road  
Poughkeepsie New York 12601-5400  
U.S.A.

Such information may be available, subject to appropriate terms and conditions, including in some cases, payment of a fee.

The licensed program described in this document and all licensed material available for it are provided by IBM

under terms of the IBM Customer Agreement, IBM International Program License Agreement or any equivalent agreement between us.

For license inquiries regarding double-byte (DBCS) information, contact the IBM Intellectual Property Department in your country or send inquiries, in writing, to:

IBM World Trade Asia Corporation  
Licensing  
2-31 Roppongi 3-chome, Minato-ku  
Tokyo 106, Japan

The following paragraph does not apply to the United Kingdom or any other country where such provisions are inconsistent with local law: INTERNATIONAL BUSINESS MACHINES CORPORATION PROVIDES THIS PUBLICATION "AS IS" WITHOUT WARRANTY OF ANY KIND, EITHER EXPRESS OR IMPLIED, INCLUDING, BUT NOT LIMITED TO, THE IMPLIED WARRANTIES OF NON-INFRINGEMENT, MERCHANTABILITY OR FITNESS FOR A PARTICULAR PURPOSE. Some states do not allow disclaimer of express or implied warranties in certain transactions, therefore, this statement may not apply to you.

This information could include technical inaccuracies or typographical errors. Changes are periodically made to the information herein; these changes will be incorporated in new editions of the publication. IBM may make improvements and/or changes in the product(s) and/or the program(s) described in this publication at any time without notice.

Any references in this information to non-IBM Web sites are provided for convenience only and do not in any manner serve as an endorsement of those Web sites. The materials at those Web sites are not part of the materials for this IBM product and use of those Web sites is at your own risk.

If you are viewing this information softcopy, the photographs and color illustrations may not appear.

---

## Trademarks

The following are trademarks of International Business Machines Corporation in the United States, or other countries, or both:

CICS  
DB2  
DFSMS/MVS  
FAA  
IBM  
MVS/DFP  
MVS/ESA  
OpenEdition  
OS/390  
S/370  
S/390  
SP  
System/370  
VM/ESA  
VSE/ESA  
VTAM  
400

---

# Glossary

## A

**ABEND.** An acronym for ABnormal END, the termination of a task or job before its completion because of an error condition that cannot be resolved by error recovery facilities while the task or job is running.

**Access Register.** Specialized high speed storage location, 32 bits in size. An S/370™ (or S/390) processor has 16 ARs, A0-A15. The AR contents are used in ESA/370 (or ESA/390) mode to specify the dataspace to be used by an ESA-exploitative machine instruction.

**active block.** The currently executing block that invokes the Interactive Debug Facility or any of the blocks in the CALL chain that leads up to this one.

**Address Stop.** See *Storage Alteration Stop*.

**AdStop.** See *Storage Alteration Stop*.

**AdStops window.** The IDF window which lists the currently active Storage Alteration Stops (AdStops) and Register Alteration Stops (RegStops). This window is only available on CMS, when IDF's of PER is enabled.

**alias.** An alternative name for a field.

**AR.** See *Access Register*.

**argument.** Data passed from one program or procedure to another. Contrast with *parameter*.

| **ASMIDF.** See *Interactive Debug Facility*.

**assemble.** To translate a program written in assembly language into a machine-language program.

**assembler.** A program that translates instructions written in assembly language into machine language.

**attention interrupt.** An I/O interrupt caused by a terminal or workstation user pressing an attention key, or its equivalent.

**attention key.** A function key on terminals or workstations that, when pressed, causes an I/O interrupt in the processing unit.

**attribute.** A characteristic or trait you can specify.

## B

**batch.** Pertaining to a predefined series of actions performed with little or no interaction between a user and the system. Contrast with *interactive*.

**batch job.** A job submitted for batch processing. See *batch*. Contrast with *interactive*.

**block.** In programming languages, a compound statement that coincides with the scope of at least one of the declarations contained within it.

**Break window.** The IDF window which lists the currently active breakpoints. These include those breakpoints set by the BREAK, DBREAK, and WATCH commands.

**breakpoint.** A place in a program, usually specified by a command or a condition, where execution can be interrupted and control given to the user or to the Interactive Debug Facility.

## C

**Command window.** The IDF window which contains the command input area, the message display areas, and (optionally) the display of the PF key captions.

**Common Programming Interface (CPI).** Definitions of those application development languages and services that have (or are intended to have) implementations on and a high degree of commonality across SAA environments. See also *Systems Application Architecture*.

**compile.** To translate a program written in a high level language into a machine-language program.

**compile unit.** A sequence of statements that make a portion of a program complete enough to compile (or assemble, as appropriate) correctly. Each language has different rules for what comprises a compile unit.

**compiler.** A program that translates instructions written in a high level programming language into machine language.

**condition.** Any synchronous event that may need to be brought to the attention of an executing program or the language routines supporting that program. Conditions fall into two major categories: conditions detected by the hardware or operating system, which result in an interrupt; and conditions defined by the programming language and detected by

language-specific generated code or language library code. See also *exception*.

**constant.** A name used to represent a data item whose value cannot be changed while the program is running. Contrast with *variable*.

**Control Register.** Specialized control facility, 32 bits in size. A S/370 (or S/390) processor has 16 GPRs, C0-C15. The CR contents are used to control processor modes and facilities.

**CR.** See *Control Register*.

**CPI.** See *Common Programming Interface*.

**Current Registers window.** The IDF window which displays the current PSW and registers. By default, the current General Purpose Registers (GPRs) and Floating Point Registers (FPRs) are shown, but the current Access Registers (ARs) or Control Registers (CRs) may be shown instead.

**currently-qualified.** See *qualification*.

## D

**data type.** A characteristic that determines the kind of value that a field can assume.

**data set.** The major unit of data storage and retrieval, consisting of a collection of data in one of several prescribed arrangements and described by control information to which the system has access.

**DBCS.** See *double-byte character set*.

**DCSS.** DisContiguous Shared Segment (CMS).

**debug.** To detect, diagnose, and eliminate errors in programs.

**default.** A value assumed for an omitted operand in a command. Contrast with *initial setting*.

**disassemble.** To translate machine language into assembly language instructions and data statements.

**disassembler.** A program that translates machine language into assembly language instructions and data statements.

**disassembly.** (1) The assembly language instructions and data statements which result from using a disassembler to disassemble machine language. (2) The act of using a disassembler.

**Disassembly window.** The IDF windows which display the results of an IDF DISASM command. This storage display will normally take the form of

disassembled machine instructions. If IDF Language extract data for these storage locations has been loaded with LANGUAGE LOAD, then program source statements will be shown interleaved with the machine instructions. You can control the display of source and disassembly with various IDF commands.

**display.** A visual presentation of information on a workstation, usually in a specific format. Sometimes called a screen or panel.

**display attribute.** A characteristic that determines how an item appears on the display. Display attributes can include the color of an item. See also *type style*.

**display line.** A viewable line of text in a window, whose exact appearance is determined by factors such as window size.

**DLBL.** VSE only. Disk label information. Further information is available in the *VSE/ESA System Control Statements* book.

**double-byte character set (DBCS).** A set of characters in which each character is represented by two bytes. Languages such as Japanese, which contain more symbols than can be represented by 256 code points, need double-byte character sets. Because each character needs two bytes, the typing, displaying, and printing of DBCS characters needs hardware and programs that support these characters.

**dump.** (1) The formatted display of storage contents. Typically formatted with a hexadecimal representation of the data on the left, and a character interpretation on the right. (2) A file or data set containing storage contents, intended for use in offline debug. See also *postmortem debug*.

**Dump window.** The IDF windows which display the results of an IDF DUMP command. This storage display will take the form of a dump, with the left side of the display containing the storage contents in hexadecimal, and the right side containing a character interpretation.

**dynamic.** In programming languages, pertaining to properties that can only be established during the execution of a program; for example, the length of a variable-length data object is dynamic. Contrast with *static*.

## E

**entry point.** The address or label of the first instruction executed on entering a computer program, routine, or subroutine. A computer program may have a number of different entry points, each perhaps corresponding to a different function or purpose.

## Glossary

**exception.** An abnormal situation in the execution of a program which typically alters its normal flow. See also *condition*.

**execute.** To cause a program, utility, or other machine function to carry out the instructions contained within. See also *run*.

**execution time.** See *run time*.

**execution-time environment.** See *run-time environment*.

**exit exec.** The same as an *exit routine*.

**exit routine.** A customization feature which associates an IDF macro or another program with a particular event.

**expression.** A group of constants or variables separated by operators that yields a single value. An expression can be arithmetic, relational, logical, or a character string.

## F

**file.** (1) A named set of records stored or processed as a unit. (2) A system object containing records: for example, a VM file, or an MVS member or partitioned data set. See *data set*.

**Floating Point Register.** Specialized high speed storage location, 64 bits in size. A S/370 (or S/390) processor has 4 FPRs, F0, F2, F4 and F6, though support is now available for 16. The FPR contents may be used as a 32 bit *Short S/370* floating point value, or as a 64 bit *Long S/370* floating point value depending on the machine instruction.

**FPR.** See *Floating Point Register*.

**font.** A set of characters or symbols of a given size, shape, and style.

**frequency count.** In the Interactive Debug Facility, a count of the number of times statements in the currently qualified program unit have been run.

**Frequency.** A choice located on the Compact Source or Compact Listing window action bar that allows you to monitor the frequency with which program statements are carried out.

**full-screen mode.** An interface mode for use with a non-programmable terminal which displays a variety of information about the program you are debugging.

## G

**General Purpose Register.** Specialized high speed storage location, 32 bits in size. A S/370 (or S/390) processor has 16 GPRs, R0-R15. The GPR contents may be used as a counter, index, or address value, depending on the machine instruction.

**GPR.** See *General Purpose Register*.

**group.** A set of records that are associated together as a logical unit.

## H

**high level language (HLL).** A programming language such as C, PL/I or COBOL.

**HLL.** See *high level language*.

**HLASM.** Acronym for High Level Assembler.

## I

**IBM Language Environment for MVS and VM (LE/370).** An IBM software product that provides a common run-time environment and common run-time services for IBM SAA High Level Language compilers.

**Interactive Debug Facility.** The IBM product informally known as IDF, an application development and maintenance facility for debugging assembly language programs.

**Interactive Debug Facility macro.** A REXX EXEC which contains Interactive Debug Facility commands.

**inactive block.** A block that is not currently executing, or is not in the CALL chain leading to the active block. See also *active block*, *block*.

**initial setting.** A value in effect when the user's Interactive Debug Facility session begins. Contrast with *default*.

**interactive.** Pertaining to a program or system that alternately accepts input and then responds. An interactive system is conversational; that is, a continuous dialog exists between a user and the system. Contrast with *batch*.

**I/O.** Input/output.

## L

**Language Support Module.** The IDF subsystem which provides Language Support extensions to the basic machine-level (object-level, disassembly-level) debug capabilities of IDF, originally packaged as a separate module.

**LE/370.** See *IBM Language Environment for MVS and VM*.

**library routine.** A routine maintained in a program library.

**line mode.** An interface mode for use with a non-programmable terminal which uses a single command line to accept Interactive Debug Facility commands.

**link-edit.** To create a loadable computer program using a linkage editor.

**linkage editor.** A program that resolves cross-references between separately compiled object modules and then assigns final addresses to create a single relocatable load module.

**listing.** A printout that lists the source language statements of a program with all preprocessor statements, includes, and macros expanded.

**load module.** A program in a form suitable for loading into main storage for execution.

**LUname.** Defines the VTAM logical unit name of the terminal used by IDF in VSE.

**LSM.** See *Language Support Module*.

**LSM Information window.** The IDF windows which contains information generated by IDF Language Support commands.

## M

**MainFrame Interface (MFI).** This refers to the use of a nonprogrammable terminal such as an IBM 3270.

**Maximize.** The action used to remove a window entry from the Minimized Windows Viewer, and restore it to its previous position on the display.

**MFI.** See *MainFrame Interface*.

**Minimize.** The action used to remove an IDF window from the display and replaces it with an entry in the Minimized Windows Viewer.

**Minimized Windows Viewer.** An IDF window which contains entries which represent minimized IDF windows.

**module.** The "package" which contains the executable code and data for a program. This may be in the form of a file, or an area of storage.

**multitasking.** A mode of operation that enables the concurrent performance, or interleaved execution, of two or more tasks.

## N

**name pattern.** A set of criteria used to display a list of variable names.

## O

**Old Registers window.** The IDF window which displays the PSW and registers contents from the previous point when IDF had control. By default, the previous General Purpose Registers (GPRs) and Floating Point Registers (FPRs) are shown, but the previous Access Registers (ARs) or Control Registers (CRs) may be shown instead.

**Options window.** The IDF window which contains current values of the IDF options and settings.

## P

**panel.** In the MFI Interactive Debug Facility, an area of the screen used to display a specific type of information.

**parameter.** Data received by a program or procedure from another. Contrast with *argument*.

**partitioned data set (PDS).** A data set in direct access storage that is divided into partitions, called members, each of which can contain a program, part of a program, or data.

**path point.** A point in the program where control is about to be transferred to another location or a point in the program where control has just been given.

**PDS.** See *partitioned data set*.

**PER.** Program Event Recording

**postmortem debug.** To detect, diagnose and eliminate errors in programs after the program has ABENDED. This is typically performed offline, using a dump file or data set.

## Glossary

**prefix area.** The eight columns to the left of the program source or listing containing line numbers. In the Interactive Debug Facility, statement breakpoints can be set in the prefix area.

**primary entry point.** See *entry point*.

**Processor Status Word.** This register describes the current S/370 (or S/390) processor execution state. Various fields contain the current:

- addressing mode
- execution address
- condition-code setting
- storage access key
- problem or supervisor state indicator
- other state indicators

**procedure.** (1) In a programming language, a block, with or without formal parameters, whose execution is invoked by means of a procedure call. (2) A set of related control statements. For example, a VM/370 exec, or an MVS CLIST.

**profile.** A group of customizable settings that govern how the user's session appears and operates.

**Profile.** A choice that allows you to change some characteristics of the working environment, such as the pace of statement execution in the Interactive Debug Facility.

**program.** A sequence of instructions suitable for processing by a computer. Processing can include the use of an assembler, a compiler, an interpreter, or a translator to prepare the program for execution, as well as to execute it.

**program part.** A compile unit associated with an application program. All program parts known to the Interactive Debug Facility are displayed in the MAP window.

**program unit.** See *compile unit*.

**programmable workstation (PWS).** A workstation that has some degree of processing capability and that allows you to change its functions (for example, a small computer such as an IBM Personal System/2<sup>®</sup> (PS/2<sup>®</sup>) as a terminal device along with appropriate 3270 emulation software).

**PSW.** See *Processor Status Word*.

**PWS.** See *programmable workstation*.

## Q

**qualification.** A method used to specify to what procedure or load module a particular variable name, function name, label, or statement id belongs. The SET QUALIFY command changes the current implicit qualification.

## R

**record.** A group of related data, words, or fields treated as a unit, such as one name, address, and telephone number.

**record format.** The definition of how data is structured in the records contained in a file. The definition includes record name, field names, and field descriptions, such as length and data type. The record formats used in a file are contained in the file description.

**reference.** (1) In programming languages, a language construct designating a declared language object. (2) A subset of an expression that resolves to an area of storage; that is, a possible target of an assignment statement. It can be any of the following: a variable, an array or array element, or a structure or structure element. Any of the above can be pointer-qualified where applicable.

**Register.** Specialized high speed storage location or control facility. See *General Purpose Register, Floating Point Register, Access Register, and Control Register*.

**Register Alteration Stop.** This is a special breakpoint available when IDF on CMS has exploitation of the virtual machine Program Event Recorder (PER) mode enabled. IDF will receive control when any of the specified registers is altered.

**Register Stop.** See *Register Alteration Stop*.

**RegStop.** See *Register Alteration Stop*.

**run.** (1) To cause a program, utility, or other machine function to execute. (2) An action that causes a program to begin execution and continue until a run-time exception occurs. If a run-time exception occurs, you can use debug windows to interact with the Interactive Debug Facility.

**run time.** Any instant at which a program is being executed.

**run-time environment.** A set of resources that are used to support the execution of a program.

**run unit.** A group of one or more object programs that are run together.

## S

**SAA.** See *Systems Application Architecture*.

**SBCS.** See *single-byte character set*.

**semantic error.** An error in the implementation of a program's specifications. The semantics of a program refer to the meaning of a program. Unlike syntax errors, semantic errors (since they are deviations from a program's specifications) can be detected only at run time.

**sequence number.** A number that identifies the records within a VM file, or an MVS member or partitioned data set.

**session.** The events that take place between the time you start an application and the time you exit the application.

**shortcut keys.** A key or combination of keys that starts an application-defined function. The IDF user interface term for accelerator keys or *hot keys*.

**single-byte character set (SBCS).** A character set in which each character is represented by a one-byte code.

**Skipped Subroutines window.** The IDF window which lists the currently active "Skipped Subroutine" breakpoints. These are set by the SKIPSTEP command.

**source.** (1) The statements in a file that make up a program. (2) In Interactive Debug Facility, the representation of a program's source statements displayed in the Disassembly window.

**static.** In programming languages, pertaining to properties that can be established before execution of a program; for example, the length of a fixed length variable is static. Contrast with *dynamic*.

**status area.** An area appended to a window that shows the keyboard shift state for DBCS on a DBCS-enabled workstation.

**Target Status window.** The IDF window which lists information about the program modules which are currently defined to IDF.

**step.** (1) One statement in a computer routine. (2) To cause a computer to execute one or more statements.

**storage.** (1) A unit into which recorded text can be entered, in which it can be retained, and from which it can be retrieved. (2) The action of placing data into a storage device. (3) A storage device.

**Storage Alteration Stop.** This is a special breakpoint available when IDF on CMS has exploitation of the virtual machine Program Event Recorder (PER) mode enabled. IDF will receive control when storage within the specified address ranges is altered.

**subroutine.** A sequenced set of instructions or statements that can be used in one or more computer programs at one or more points in a computer program.

**suffix area.** A variable-sized column to the right of the program source or listing statements, containing frequency counts for the first statement or verb on each line. In the Interactive Debug Facility, the MFI optionally displays the suffix area in the Disassembly window. See also *prefix area*.

**synchronous.** Pertaining to two or more processes that depend on the occurrence of specific events. Contrast with *batch*, *interactive*.

**syntactic analysis.** An analysis of a program done by a compiler to determine the structure of the program and the construction of its source statements to determine whether it is valid for a given programming language. See also *syntax error*.

**syntax.** The rules governing the structure of a programming language and the construction of a statement in a programming language.

**syntax error.** Any deviation from the grammar (rules) of a given programming language appearing when a compiler performs a syntactic analysis of a source program. See also *syntactic analysis*.

**Systems Application Architecture (SAA).** A set of IBM software interfaces, conventions, and protocols that provide a framework for designing and developing applications that are consistent across systems.

## T

**token.** A character string in a specific format that has some defined significance in a programming language.

**triglyph.** A group of three characters which, taken together, are equivalent to a single special character.

**type style.** A form of highlighting of characters and symbols within a font set. For example, bold, italic, strikeout, or underscore. See also *display attribute*.

## U

**utility.** A computer program in general support of computer processes; for example, a diagnostic program, a trace program, or a sort program.

## Glossary

### V

**variable.** A name used to represent a data item whose value can be changed while the program is running. Contrast with *constant*.

### W

**window.** A division of the display screen in which one of several IDF commands can concurrently display information.

**windowing.** Dividing a display screen into distinct areas in which different display images can be viewed at the same time.

**workstation.** One or more programmable or nonprogrammable devices, usually connected to a host or a network, at which you can run applications. See also *programmable workstation*.

---

## Bibliography

---

### High Level Assembler Publications

*HLASM General Information*, GC26-4943

*HLASM Installation and Customization Guide*, SC26-3494

*HLASM Language Reference*, SC26-4940

*HLASM Licensed Program Specifications*, GC26-4944

*HLASM Programmer's Guide*, SC26-4941

---

### Toolkit Feature Publications

*HLASM Toolkit Feature User's Guide*, GC26-8710

*HLASM Toolkit Feature Debug Reference Summary*, GC26-8712

*HLASM Toolkit Feature Interactive Debug Facility User's Guide*, GC26-8709

*HLASM Toolkit Feature Installation Guide*, GC26-8711

---

### Related Publications (Architecture)

*Enterprise Systems Architecture/390 Principles of Operation*, SA22-7201

*Vector Operations*, SA22-7207

*System/370 Enterprise Systems Architecture Principles of Operation*, SA22-7200

*System/370 Principles of Operation*, GA22-7000

*System/370 Extended Architecture Principles of Operation*, SA22-7085

---

### Related Publications for MVS

**OS/390 MVS:**

*OS/390 MVS JCL Reference*, GC28-1757

*OS/390 MVS JCL User's Guide*, GC28-1758

*OS/390 MVS Programming: Assembler Services Guide*, GC28-1757

*OS/390 MVS Programming: Assembler Services Reference*, GC28-1910

*OS/390 MVS Programming: Authorized Assembler Services Guide*, GC28-1763

*OS/390 MVS Programming: Authorized Assembler Services Reference ALE-DYN*, GC28-1764

*OS/390 MVS Programming: Authorized Assembler Services Reference ENF-IXG*, GC28-1765

*OS/390 MVS Programming: Authorized Assembler Services Reference LLA-SDU*, GC28-1766

*OS/390 MVS Programming: Authorized Assembler Services Reference SET-WTO*, GC28-1767

*OS/390 MVS System Codes*, GC28-1780

*OS/390 MVS System Commands*, GC28-1781

*OS/390 MVS System Messages, Vol 1 (ABA-ASA)*, GC28-1784

*OS/390 MVS System Messages, Vol 2 (ASB-ERB)*, GC28-1785

*OS/390 MVS System Messages, Vol 3 (EWX-IEB)*, GC28-1786

*OS/390 MVS System Messages, Vol 4 (IEC-IFD)*, GC28-1787

*OS/390 MVS System Messages, Vol 5 (IGD-IZP)*, GC28-1788

#### **MVS/ESA Version 5:**

*MVS/ESA JCL Reference*, GC28-1479

*MVS/ESA JCL User's Guide*, GC28-1473

*MVS/ESA Programming: Assembler Services Guide*, GC28-1466

*MVS/ESA Programming: Assembler Services Guide*, GC28-1474

*MVS/ESA Programming: Authorized Assembler Services Guide*, GC28-1467

*MVS/ESA Programming: Authorized Assembler Services Reference Volumes 1 - 4*, GC28-1475, GC28-1476, GC28-1477, GC28-1478

*MVS/ESA System Codes*, GC28-1486

*MVS/ESA System Commands*, GC28-1442

*MVS/ESA System Messages Volumes 1 - 5*, GC28-1480, GC28-1481, GC28-1482, GC28-1483, GC28-1484

#### **MVS/ESA OpenEdition®:**

*MVS/ESA OpenEdition MVS User's Guide*, SC23-3013

#### **OS/390 OpenEdition:**

*OS/390 UNIX System Services User's Guide*, SC28-1891

**MVS/DFP™:**

## Bibliography

*MVS/DFP Version 3.3: Utilities*, SC26-4559

*MVS/DFP Version 3.3: Linkage Editor and Loader*, SC26-4564

### **DFSMS/MVS®:**

*OS/390 DFSMS Program Management*, SC27-0806

### **TSO/E (MVS):**

*TSO/E Command Reference*, SC28-1881

### **TSO/E (OS/390):**

*OS/390 TSO/E Command Reference*, SC28-1969

### **MVS SMP/E:**

*SMP/E Messages and Codes*, SC28-1108

*SMP/E Reference*, SC28-1107

*SMP/E Reference Summary*, SX22-0006

*SMP/E User's Guide*, SC28-1302

### **OS/390 SMP/E:**

*OS/390 SMP/E Messages and Codes*, SC28-1738

*OS/390 SMP/E Reference*, SC28-1806

*OS/390 SMP/E User's Guide*, SC28-1740

---

## Related Publications for VM

*VM/ESA CMS Application Development Guide*, SC24-5761

*VM/ESA CMS Application Development Guide for Assembler*, SC24-5763

*VM/ESA CMS Application Development Reference*, SC24-5762

*VM/ESA CMS Application Development Reference for Assembler*, SC24-5764

*VM/ESA CMS User's Guide*, SC24-5775

*VM/ESA XEDIT Command and Macro Reference*, SC24-5780

*VM/ESA XEDIT User's Guide*, SC24-5779

*VM/ESA CP Command and Utility Reference*, SC24-5750

*VM/ESA Planning and Administration*, SC24-5773

*VMSES/E Introduction and Reference*, SC24-5837

*VM/ESA Service Guide*, SC24-5838

*VM/ESA CMS Command Reference*, SC24-5776

*VM/ESA CMS File Pool Planning, Administration, and Operation*, SC24-5751

*VM/ESA System Messages and Codes Reference*, SC24-5841

---

## Related Publications for VSE

*VSE/ESA Administration*, SC33-6505

*VSE/ESA Guide to System Functions*, SC33-6511

*VSE/ESA Installation*, SC33-6504

*VSE/ESA Planning*, SC33-6503

*VSE/ESA System Control Statements*, SC33-6513

---

## General Publications

*BRIEF OS/390 Software Management Cookbook*, SG24-4775

# Index

## Special Characters

? command 167

/ command 137

## Numerics

1ADSTOP option

at invocation 21

## A

abbreviations

list of 272

ABEND

causing 88

ABEND command 88

ABNEXIT 49

Access registers

initial contents 32

addresses

displayed by IDF 75

ADSTOP command 88

AdStops

availability of 51

clearing 60

ADSTOPS command 89

AFPR command 89

alarm

sound from macro 89

ALARM command 89

ALET command 90

ALET for a Dump window

setting 90

allocation map

storage

display 187

extraction 244

obtaining 244

alteration

variable

optimized 100

AMODE24 option

at invocation 21

AMODE31 option

at invocation 21

APROGMSG command 90

APROGMSG option

setting 90

AREGS command 91

arguments 73, 75

passing to CMS program 44

passing to TSO program 36

arguments (*continued*)

passing to VSE program 54

ARRAY 91

display scrolling 121

ARRAY command 91

array element

based 81, 91

data attributes

obtaining 224

data display

obtaining 224

extraction 224

information

obtaining 224

array elements

data display 91

arrow, as base indicator 73

ASCII

storage

displayed in 63, 65

modified in 63, 66

ASCII option

at invocation 21

ASM ASMLANGX option 252

ASMIDF

See IDF

ASMLANGX

extraction file

allocation on TSO 15

optimum BLKSIZE 15

return codes 18

ASMLANGX options

ASM 252

CONDASM 252

DCL 252

DEBUG 252

ERROR 252

IFM 253

INCL 253

LOUD 253

MACDEF 254

NOCONDASM 252

NODCL 252

NOINCL 253

NOMACDEF 254

NOPACK 254

NOSEQ 255

OFM 254

OFN 254

OFT 254

PACK 254

PFM 255

## Index

### ASMLANGX options (*continued*)

- PFT 255
- QUIET 253
- SEQ 255

### ASMLKEDT

- JCL Requirements for VSE 15

### assembly

- needed option 14
- preparation 14
- requirements 14

### asynchronous events 51

### asynchronous program-checks

- trapping 90

- attention key 42, 57

- AUDIT command 92

### AUDIT option

- setting 92

- AUTOLOAD option 186

- at invocation 21

- AUTOSIZE option 60

- at invocation 22

## B

- BACK command 93

### base address of program

- setting 93

- BASE command 93

- base for data input 73

### based

- array element 81, 91

- structure 81, 188

- union 81, 188

- variable 81, 82

### basing expression

- display 92

### batch mode

- See Interface modes

### BCX option

- at invocation 22

- BINARY command 113

- BIT command 94

### block comment

- display 123

- BOTTOM command 94

- BREAK command 95

### break-in event

- CMS 50

- TSO 42

- VSE 57

### breakpoints

- clearing 61

- examining from a macro 225

- execute until next reached 169

- exit routine 214

- missed 51

### breakpoints (*continued*)

- name 214

- RC from exit routine to accept or ignore 216

- set from macro 173

- setting 95

- types of 51, 95, 96

- when taken 95

- BRIEF command 97, 103

### BRIEF option

- setting 97

## C

### call chain

- display 98, 170, 171

- extraction 225

- save areas 98, 170, 171

### call hierarchy

- display 98, 170, 171

- extraction 225

- save areas 98, 170, 171

- CALLERS command 98

- capabilities 2

### chains

- following storage 110

- CHARACTER command 99

- CHECK command 100

### CICS

- on VSE 56

- CKSUBCM option

- at invocation 22

- CLOSE command 101

- CMDLOG option 29, 72, 141

- at invocation 22, 29

- CMPEXIT option

- at invocation 23

- loading exit routing 217

### CMS programs

- debugging 44

- preparation 44

### CMS SUBSET

- obtaining 189

### CMS User Area

- programs, debugging 45

- COLOR command 122

### colors

- examining current setting 227

- redefining

- at invocation 23

- in macro 101

- COLORS command 101

### COLORS option

- at invocation 23

- COLOUR command 122

### COLOURS option

- at invocation 23

command 167  
   as PF key function 85  
   cross-reference 85  
   entering on command line 102  
   retrieve previous 167  
 COMMAND command 102  
 command line  
   entering addresses on 73  
   obtaining contents from within a macro 226  
   placing text on from a macro 174  
   processing 102  
 COMMAND option 37, 39, 47  
   at invocation 23  
 commands 85  
   ? 167  
   / 137  
   ABEND 88  
   ADSTOP 88  
   ADSTOPS 89  
   AFPR 89  
   ALARM 89  
   ALET 90  
   APROGMSG 90  
   AREGS 91  
   ARRAY 91  
   AUDIT 92  
   BACK 93  
   BASE 93  
   BINARY 113  
   BIT 94  
   BOTTOM 94  
   BREAK 95  
   BRIEF 97, 103  
   CALLERS 98  
   CHARACTER 99  
   CHECK 100  
   CLOSE 101  
   COLORS 101  
   COMMAND 102  
   COMPACT 102  
   CREGS 103  
   CURSOR 104  
   DBREAK 104  
   DETAIL 106  
   DISASM 107  
   DOWN 152  
   DROP GLOBAL 108  
   DROP MODULE 108  
   DROP SYMBOLS 109  
   DUMP 109  
   DUMPMODE 64, 110  
   EPOFFSET 110  
   EXITEXEC 110  
   EXLIMIT 111  
   EXTRACT  
     ADSTOPS 222  
     ALET 223

commands (*continued*)  
 EXTRACT (*continued*)  
   AREGS 223  
   ARGS 223  
   ARGUMENT 223  
   ARRAY 224  
   BREAK 225  
   CALLERS 225  
   CMDMSG 226  
   COLORS 227  
   CURSOR 227  
   DISASM 228  
   EVENT 230  
   EXITEXEC 230  
   GLOBAL 230  
   GLOBAL STEM 230  
   GLOBAL STEMS 231  
   GSTATUS 231  
   ICOUNT 231  
   LANGUAGE ARGS 232  
   LANGUAGE ARGUMENTS 232  
   LANGUAGE CMDS 232  
   LANGUAGE COMMANDS 232  
   LANGUAGE OPTIONS 232  
   LANGUAGE STATUS 233  
   LANGUAGE STEM 233  
   LANGUAGE VERSION 234  
   LASTMSG 234  
   LOAD 235  
   LOCATION 235  
   LOCATION ALET 236  
   MAP 236  
   MODE 237  
   MODULES 237  
   MSTATUS 238  
   NAMES 238  
   OPTIONS 239  
   PER 239  
   PFK 239  
   PLIST 240  
   PLOCATES 240  
   QUALIFY 240  
   QUERY 241  
   REGS 241  
   REGSTOPS 242  
   SCOPE 242  
   SCRVAR 242  
   SELFNUCX 243  
   SKIPSTEP 243  
   SOURCE 244  
   STOREMAP 244  
   STRUCTURE 245  
   SVC 245  
   SYMBOLS 245  
   TASKS 247  
   TYPE 247  
   UNION 248

## Index

### commands (*continued*)

EXTRACT (*continued*)  
  VALUE 248  
  VARIABLE 248  
  VDCL 249  
  VDECLARE 249  
  VERSION 249  
  VLOC 250  
  VVALUE 250  
  WINDOWS 251  
FIND 111  
FIRST 113  
FIXED 113  
FLOAT 114  
FMT 115  
FOLLOW 114  
FORMAT 115  
FPC 116  
FPR 117  
GLOBALS 117  
GOTO 117  
GPACK 118  
GPR 118  
GSTATUS 118  
HIDE 119  
HISTORY 120  
ICOUNT 121  
KWDSYN 121  
LANGUAGE  
  + 121  
  COLOR 122  
  COMMENTS 123  
  DCLS 124  
  DEBUG 123  
  DECLARES 124  
  DROP 124  
  LOAD 125  
  MACROS 127  
  OPTIONS 128  
  SCROLL 128  
  STATUS 129  
  STEM 130  
  VERSION 130  
  XPATH 131  
LAST 131  
LASTMSG 132  
LEFT 132  
LIBE 133  
LOAD 134  
LOCATE 137  
LOCATION 137  
LOCATION ALET 138  
MACRO 138  
MAJOR 139  
MAP 139  
MAXIMIZE 67, 140

### commands (*continued*)

MINIMIZE 67, 140  
MODE 141  
MODULE BASE 142  
MODULE CDE 141  
MODULE NUCEXT 141  
MODULE SIZE 143  
MODULE TRANS 141  
MOVE 60, 144  
MPACK 146  
MRUN 6, 146  
MSG 148  
MSGID 148  
MSGMODE 149  
MSTATUS 150  
MSTEP 6, 150  
NAMES 151  
NEXT 152  
OFFSET 153  
OPEN 154  
OPTIONS 155  
ORDER 59, 155  
OREGS 156  
PACKED 156  
PARMS 156  
PAUSE 157  
PER 157  
PFK 8, 158  
PFKDISP 158  
PLOCATES 159  
PRESERVE 159  
PREVIOUS 160  
PROGCHK 161  
PROGCK 161  
PSW 117  
PSWSTEAL 162  
QQUIT 165  
QUALIFY 164  
QUIET 164  
QUIETLY 164  
QUIT 165  
R0-R15 170  
RCQUIT 165  
REFRESH 166  
REGS 167  
REGSTOPS 89  
RESTORE 167  
RETRIEVE 167  
RIGHT 168  
RLOG 73, 168, 196  
RUN 169  
RUNEXIT 169  
SALIMIT 170  
SAREGS 171  
SAVE 159  
SEARCH 171

commands (*continued*)

SELFNUCX 172  
 SET  
   ADSTOP 173  
   AREG 173  
   BREAK 173  
   COMMAND 174  
   EXITEXEC 174, 214, 217  
   GLOBAL 176  
   GLOBAL STEM 175  
   ICOUNT 176  
   OFFSET 176  
   OPTION 5, 177  
   OPTION AUTOSIZE 60  
   PSW 178  
   REGSTOP 179  
   SET MODULE 141  
   SET PSW 25  
   SIZE 179  
 SET OPTION 5  
 SHOW 179  
 SIZE command 181  
 SKIPSTEP 34, 79, 151, 183  
 SPACE 184  
 STATUS 184  
 STEP 185  
 STMTSTEP 185  
 STOKEY 186  
 STOREMAP 187  
 STRUCTURE 187  
 SUBSET 189  
 SVC 189  
 SWAP 189  
 SYMBOL 190  
 TASKS 191  
 TITLE 191  
 TOP 192  
 TRIGGER LOAD 192  
 TYPE 193  
 UNION 187, 194  
 UNTIL 194  
 UP 160  
 VALUE 194  
 VARIABLE 80, 195  
 VCHANGE 196  
 VERSION 196  
 VS 197  
 VSEP 197  
 WATCH 197  
 WHERE 199  
 XEDEXIT 200  
 ZONED 200  
 comments  
   display  
     enabling 179  
     excluding 119

COMMENTS command 123  
 COMPACT command 102  
 COMPACT option  
   setting 102  
 compaction  
   extract file storage 146  
   Global Storage data storage 118  
 CONDASM ASMLANGX option 252  
 Controlling 79  
 CREGS command 103  
 CSECT  
   specifying 73  
 current screen contents  
   extraction 242  
   obtaining 242  
 cursor  
   determining position of from macro 227  
   setting position from macro 104  
 CURSOR command 104  
 cursor position  
   rules used by IDF 75  
 customization  
   screen 122

**D**

data address  
   extraction 250  
   variable  
     obtaining 250  
 data attributes  
   array element  
     obtaining 224  
   display 193  
   extraction 224, 245, 247, 248, 249  
   structure  
     obtaining 245  
   variable  
     display 193  
     obtaining 247, 248, 249  
 data display  
   array element  
     obtaining 224  
   extraction 248, 249, 250  
   structure 187  
     obtaining 245  
   union 187  
   variable 80, 195  
     obtaining 248, 249, 250  
 data format  
   bit variables  
     \* 94  
     BIT 94  
     default 94  
     HEX 94  
   character variables  
     \* 99

## Index

- data format (*continued*)
  - character variables (*continued*)
    - ASCII 99
    - CHARACTER 99
    - default 99
    - EBCDIC 99
    - HEX 99
    - PACKED 99
    - ZONED 99
  - fixed variables
    - \* 113
    - DECIMAL 113
    - default 113
    - HEX 113
  - float variables
    - \* 114
    - default 114
    - FIXED 114
    - HEX 114
    - SCIENCE 114
    - STANDARD 114
    - STD 114
  - packed decimal variables
    - \* 156
    - DECIMAL 156
    - default 156
    - HEX 156
  - Zoned decimal variables
    - \* 200
    - DECIMAL 200
    - default 200
    - HEX 200
- data location
  - extraction 250
  - variable
    - obtaining 250
- data value
  - extraction 250
  - variable
    - obtaining 250
- dataset conventions
  - TSO 35
  - VSE 54
- DB2
  - debugging programs in 41
- DBREAK command 104
- DCL ASMLANGX option 252
- DD conventions
  - TSO 35
- dead code 32
- DEBUG ASMLANGX option 252
- DEBUG command 123
- debugging
  - CMS programs 44
  - TSO programs 35
  - VSE programs 54
- debugging support
  - LSM 123
- declarations
  - display
    - enabling 179
    - excluding 119
- declare display 124
- DECLARES command 124
- default
  - dump format
    - changing at invocation 31
  - ENTER key function 72
  - PF key definitions 72
- delaying execution 157
- DETAIL command 106
- DISASM command 107
- disassembly
  - display
    - enabling 179
    - excluding 119
  - obtaining from macro 228
- display
  - Access registers 91
  - allocation map
    - storage 187
  - array elements 91
  - IDF Language Support
    - options 128
    - settings 128
  - location
    - symbolic name 199
  - registers
    - Access 91
  - storage
    - allocation map 187
  - task information 191
  - value of expression 194
  - variable
    - data attributes 193
    - information 193
    - type attributes 193
- display scrolling
  - array display 121
  - LSM Information window 121
  - status display 121
  - structure display 121
  - union display 121
  - variable display 121
- DMSO option
  - at invocation 23
- documentation
  - High Level Assembler 285
  - related publications 286
- DOWN command 152
- DROP command 124

DROP GLOBAL command 108  
 DROP MODULE command 108  
 DROP SYMBOLS command 109  
 dump  
   automatic adjustment of 114  
   format  
     changing 110  
     symbolic and unformatted 65  
     differences 65  
 DUMP command 109  
 DUMP MODE command 64, 110  
 dynamically loaded programs  
   CMS 48  
   TSO 39  
   VSE 55

## E

ENTER  
   default setting 72  
 entrypoint offset of program  
   setting 110  
 environments supported 5  
 EPOFFSET command 110  
 ERROR ASMLANGX option 252  
 ESTAE exit 42  
 EVALBLOK 41, 49  
 execute to next breakpoint 169  
 execution  
   instruction counts 32, 33, 34  
   reviewing previous 120  
 exit from IDF 165  
 exit from IDF with RC 165  
 exit routine  
   arguments passed at invocation 214  
   communication between 175, 176, 230  
   compiled language 23, 216  
   conditions for execution 214  
   current  
     naming 174  
   determining current 230  
   enabling and disabling 110  
   information available to 216, 222  
   invoking by PF key 169  
   last event causing 230  
   naming at IDF invocation 24  
   writing 214  
   XEDIT the current 200  
 EXITEXEC command 110  
 EXITEXEC option 214  
   at invocation 24  
 EXLIMIT command 111  
 expression 73  
   displaying value of 194  
   indirection operators 74  
   locating 81, 82, 91

expression (*continued*)  
   obtaining value of from a macro 248  
   placing on command line from a macro 174  
 expressions  
   based 188  
   locating 188  
 extended branch mnemonics 64  
 external calls  
   hierarchy  
     display 98, 170, 171  
     extraction 225  
     save areas 98, 170, 171  
 EXTRACT 222  
   return codes from 222  
 EXTRACT ADSTOPS command 222  
 EXTRACT ALET command 223  
 EXTRACT AREGS command 223  
 EXTRACT ARGUMENT command 223  
 EXTRACT ARRAY command 224  
 EXTRACT BREAK command 225  
 EXTRACT CALLERS command 225  
 EXTRACT CMDMSG command 226  
 EXTRACT COLORS command 227  
 EXTRACT CURSOR command 227  
 EXTRACT DISASM command 228  
 EXTRACT EVENT command 230  
 EXTRACT EXITEXEC command 230  
 extract file  
   association  
     querying 139  
   dropping  
     all 124  
     individual 124  
   loading 125  
   memory compaction 146  
   memory status information 150  
     obtaining 150  
   querying loaded files 129, 150  
   search path 131  
 EXTRACT GLOBAL command 230  
 EXTRACT GLOBAL STEM command 230  
 EXTRACT GLOBAL STEMS command 231  
 EXTRACT GSTATUS command 231  
 EXTRACT ICOUNT command 231  
 EXTRACT LANGUAGE ARGUMENTS command 232  
 EXTRACT LANGUAGE COMMANDS command 232  
 EXTRACT LANGUAGE OPTIONS command 232  
 EXTRACT LANGUAGE STATUS command 233  
 EXTRACT LANGUAGE STEM command 233  
 EXTRACT LANGUAGE VERSION command 234  
 EXTRACT LASTMSG command 234  
 EXTRACT LOAD command 235  
 EXTRACT LOCATION ALET command 236  
 EXTRACT LOCATION command 235  
 EXTRACT MAP command 236

## Index

- EXTRACT MODE command 237
  - EXTRACT MODULES command 237
  - EXTRACT MSTATUS command 238
  - EXTRACT NAMES command 238
  - EXTRACT OPTIONS command 239
  - EXTRACT PER command 239
  - EXTRACT PFK command 239
  - EXTRACT PLIST command 240
  - EXTRACT PLOCATES command 240
  - EXTRACT QUALIFY command 240
  - EXTRACT QUERY command 241
  - EXTRACT REGS command 241
  - EXTRACT REGSTOPS command 242
  - EXTRACT SCOPE command 242
  - EXTRACT SCRVAR command 242
  - EXTRACT SELFNUCX command 243
  - EXTRACT SKIPSTEP command 243
  - EXTRACT SOURCE command 244
  - EXTRACT STOREMAP command 244
  - EXTRACT STRUCTURE command 245
  - EXTRACT SVC command 245
  - EXTRACT SYMBOLS command 245
  - EXTRACT TASKS command 247
  - EXTRACT TYPE command 247
  - EXTRACT UNION command 248
  - EXTRACT VALUE command 248
  - EXTRACT VARIABLE command 248
  - EXTRACT VDECLARE command 249
  - EXTRACT VERSION command 249
  - EXTRACT VLOC command 250
  - EXTRACT VVALUE command 250
  - EXTRACT WINDOWS command 251
  - extracting currently qualified module 240
  - extraction
    - allocation map
      - storage 244
    - current screen contents 242
    - Global Storage
      - status information 231
    - Global Storage status information
      - obtaining 231
    - ICOUNT 231
    - IDF Language Stem Name 233
    - IDF Language Support settings 232, 241
    - IDF Language Support version 234
    - IDF settings 241
    - LANGUAGE arguments 232
    - LANGUAGE commands 232
    - memory status information 238
      - obtaining 238
    - module
      - location 236
    - pointer Located variables 240
    - source records 244
    - statement scope 242
    - status information 233
  - extraction (*continued*)
    - storage
      - allocation map 244
      - task information 247
      - variable names 238
  - extraction file
    - ASMLANGX
      - allocation on TSO 15
      - optimum BLKSIZE 15
- ## F
- FASTPATH option 32
    - at invocation 24
  - file mode
    - obtaining current from macro 237
    - setting 141
  - FIND command 111
  - FIRST command 113
  - FIXED command 113
  - flag byte (R1) 44
  - FLOAT command 114
  - float variable 114
  - Floating Point registers
    - initial contents 32
  - FMT command 115
  - FOLLOW command 114
  - Following linked list 110
  - FORMAT command 115
  - format notation, description xiii—xv
  - FPC command 116
  - FPR
    - initial contents 32
  - FPR command 117
  - full-screen applications
    - debugging 43, 52, 58
  - FULLQUAL option 75, 228, 229
    - at invocation 24
- ## G
- getting started 8
    - program debug 8
    - program preparation 8
  - Global Storage
    - deleting stem 108
    - dynamically loaded
      - deleting stem 108
    - memory compaction 118
    - querying defined stems 117, 231
    - querying stem definitions 118
    - status information 118
      - extraction 231
      - obtaining 118
  - GLOBALS command 117

GOTO command 117  
 GPACK command 118  
 GPR command 118  
 GPR registers  
   initial contents 31  
 GSTATUS command 118

## H

HEXDISP option  
   at invocation 24  
   showing displacements 229  
 HEXINPUT option 248  
   at invocation 25  
 HIDE command 119  
 HISTORY command 120  
 HLASM  
   assembly  
     preparation 14  
     program build  
       requirements 14  
 HNDEXT 49, 52  
 hostspot 32

## I

ICOUNT command 121  
 IDF  
   invoking 19  
 IDF Language Stem Name  
   obtaining 233  
 IDF Language StemName  
   extraction 233  
 IDF Language Support  
   debugging information 26  
   Logical Unit name 26  
 IDF Language Support settings  
   extraction 232, 241  
   obtaining 232  
 IDF Language Support version  
   extraction 234  
   obtaining 234  
 IDF settings  
   extraction 241  
   preserving 159  
   restoring 167  
   saving 159  
   stack 159, 167  
 IMF ASMLANGX option 253  
 IMPMACRO option  
   at invocation 25  
 INCL ASMLANGX option 253  
 indirection operators 74  
 information  
   array element  
     obtaining 224

information (*continued*)  
   structure  
     obtaining 245  
   variable  
     display 193  
     obtaining 247, 248, 249, 250  
 informational message display  
   controlling 164  
 input checks  
   bounds 100  
   disabling 100  
   enabling 100  
   negative values 100  
   substring 100  
   unsigned variables 100  
 instructions  
   counting execution of 121  
   reviewing previous 120  
 Interface modes  
 interrupt routines 28  
 interrupts 51  
   handled by CMS 49  
 invocation  
   user area programs 19  
   validity checking at 19  
 invocation options 20  
 invoking IDF 19  
 invoking IDF on TSO  
   from a CLIST 35, 38  
   from a REXX EXEC 35, 38  
   from the TSO/E READY prompt 35, 38  
 IDF files  
   ALLOC of DDs 38  
   FREE of DDs 38  
   under ISPF 35, 38  
   user files  
     ALLOC of DDs 38  
     FREE of DDs 38  
 invoking IDF on VSE  
   IDF files 54  
 INVPSW option 178  
   at invocation 25  
 ISA location 50  
 ISA option  
   at invocation 25  
 ISPF  
   debugging programs in 41

## J

JCL Requirements for VSE  
 ASMLKEDT 15

## Index

### K

key  
  storage 186  
keywords  
  abbreviations for 272  
  synonyms of 121  
KWDSYN command 121

### L

LANGUAGE  
  + 121  
  COLOR 122  
  COMMENTS 123  
  DEBUG 123  
  DECLARES 124  
  DROP 124  
  LOAD 125  
  OPTIONS 128  
  SCROLL 128  
  STATUS 129  
  STEM 130  
  VERSION 130  
  XPATH 131  
LANGUAGE + command 121  
LANGUAGE COLOR command 122  
LANGUAGE commands  
  extraction 232  
  obtaining 232  
LANGUAGE COMMENTS command 123  
LANGUAGE DCLS command 124  
LANGUAGE DEBUG command 123  
LANGUAGE DECLARES command 124  
LANGUAGE DROP command 124  
LANGUAGE LOAD command 125  
LANGUAGE MACROS command 127  
LANGUAGE OPTIONS command 128  
LANGUAGE SCROLL command 128  
LANGUAGE STATUS command 129  
LANGUAGE STEM command 130  
language support  
  additional capabilities 78  
LANGUAGE VERSION command 130  
LANGUAGE XPATH command 131  
LAST command 131  
LASTMSG command 132  
LEFT command 132  
LIBE option  
  at invocation 25  
license inquiry 276  
limitations  
  on CMS 6  
  on TSO 5  
  on VSE 7  
limits  
  program's  
    CMS 50  
    TSO 42  
    VSE 57  
line address  
  terminal 26  
line numbers  
  source code  
    display 179  
LINE option 52  
  at invocation 26  
linked list  
  following 110  
LOAD command 125, 134  
loading programs 141, 142, 143  
LOADLIB  
  specifying in PROFILE macro 133  
LOCATE command 137  
locating expressions 188  
location  
  displaying  
    symbolic name 199  
LOCATION ALET command 138  
LOCATION command 137  
locator variable  
  displaying Located variables 159  
  extracting Located variables 240  
  obtaining Located variables 240  
logging 168  
LOUD ASMLANGX option 253  
LPSW Fastpath 146  
LSM  
  debugging support 123  
  index limit 111  
  named 130  
LSM Information window  
  scrolling 121  
LSM Information window scrolling 128  
LSMDEBUG option  
  at invocation 26  
LUNAME option  
  at invocation 26, 54

### M

MACDEF ASMLANGX option 254  
machine instructions, publications 285  
macro  
  options  
    examining 239  
    setting within 177  
MACRO command 138  
macro expansions  
  display  
    enabling 179  
    excluding 119

- MACROLOG option 141, 208
  - at invocation 26
- macros
  - IDF 111, 130
    - communication between 230
    - invocation by operator 138
    - return codes from 138
  - invocation of 207
  - writing 207
- macros, IDF
  - communication between 175, 176
  - restrictions
    - MRUN 6
    - MSTEP 6
- MAJOR command 139
- MAJOR option
  - setting 139
- manuals
  - High Level Assembler 285
  - related publications 286
- MAP command 139
- MAXIMIZE command 67, 140
- memory constrained environments
  - optimum BLKSIZE 16
  - XA Exploitation 16
- memory status information
  - extract file 150
  - extraction 238
- message
  - format 256
  - numbers 256
  - obtaining contents from within a macro 226
  - obtaining current value of 226
  - severity levels 256
  - trapping programs 52
- message display
  - controlling 148, 149, 164
- messages 256
  - ASMKxxxE 257
  - ASMKxxxI 257
  - ASMKxxxS 257
  - ASMKxxxT 257
  - ASMKxxxW 257
  - ASMLANGX 267
  - ASMLKEDT 257
  - ASMLxxxE 257
  - ASMLxxxI 257
  - ASMLxxxS 257
  - ASMLxxxT 257
  - ASMLxxxW 257
  - ASMMxxxE 260
  - ASMMxxxI 260
  - ASMMxxxS 260
  - ASMMxxxT 260
  - ASMMxxxW 260
  - ASMxxxE 267
- messages (*continued*)
  - ASMxxxI 267
  - ASMxxxS 267
  - ASMxxxT 267
  - ASMxxxW 267
  - IDF 260
  - IDF Language Support 257
  - issuing from a macro 148
  - obtaining contents from within a macro 234
  - retrieving previous 132
- MINIMIZE command 67, 140
- Minimized Windows Viewer 140
- missed breakpoints 51
- mnemonics
  - extended branch 64
- MODE command 141
- MODE option 72
  - at invocation 26
  - changing value 237
  - checking value 237
- MODMAP option
  - at invocation 27
- module
  - deleting definition 108
  - displaying definition 69
  - dynamically loaded
    - defining to IDF 141, 142, 143
    - deleting definition 108
  - extracting currently qualified 240
  - extracting information about 237
  - location
    - extraction 236
    - obtaining 236
    - querying 139
  - preventing IDF from loading 141
  - setting qualified 164
  - specifying 73
- MODULE BASE command 142
- MODULE CDE command 141
- MODULE NUCEXT command 141
- MODULE SIZE command 143
- MODULE TRANS command 141
- MOVE command 60, 144
- MPACK command 146
- MRUN command 146
- MSG command 148
- MSGID command 148
- MSGID option
  - interaction with CMDMSG 226
  - interaction with LASTMSG 234
  - setting 148
- MSGMODE command 149
- MSGMODE option
  - setting 149
- MSTATUS command 150

## Index

MSTEP command 150

## N

names

variable

displaying list 151

extracting list 238

NAMES command 151

NEXT command 152

NOAUTOLD option 186

at invocation 21

NOAUTOSZ option 60

at invocation 22

NOBCX option 64

at invocation 22

NOCONDASM ASMLANGX option 252

NODCL ASMLANGX option 252

NODSECTS option

at invocation 27

NOIMPMAC option

at invocation 25

NOINCL ASMLANGX option 253

NOINVPSW option 178

at invocation 25

NOMACDEF ASMLANGX option 254

NOMODMAP option

at invocation 27

NOPACK ASMLANGX option 254

NOPROFIL option

at invocation 28

NOSEQ ASMLANGX option 255

NOSTOPNP option 151, 185, 186

at invocation 29

NOSTOPST option 185

at invocation 30

NOSVC97 option 5, 36

at invocation 30

notation, description xiii—xv

NUCEXT option 46

at invocation 27

Nucleus Extensions

self loading, debugging 46

Nucleus Extensions (CMS only)

explicitly loaded, debugging 46

## O

obtaining

allocation map

storage 244

array element

data attributes 224

data display 224

information 224

current screen contents 242

obtaining (*continued*)

Global Storage status information

extraction 231

IDF Language Stem Name 233

IDF Language Support settings 232

IDF Language Support version 234

IDF settings 232

LANGUAGE arguments 232

LANGUAGE commands 232

memory status information

extract file 150

extraction 238

module

location 236

pointer Located variables 240

source records 244

statement scope 242

status information 233, 241

Global Storage 118

storage

allocation map 244

structure

data attributes 245

data display 245

information 245

task information 247

variable

data address 250

data attributes 247, 248, 249

data display 248, 249, 250

data value 250

information 247, 248, 249, 250

type attributes 247

obtaining IDF Language Support version 130

OFFSET

extracting current 235

referring to in expressions 75

setting or querying 153

OFFSET command 153

OFFSET option 153

at invocation 27

OFM ASMLANGX option 254

OFN ASMLANGX option 254

OFT ASMLANGX option 254

OLDBREAK option

at invocation 27

OPEN command 154

operating IDF 59

operators

indirection 74

optimum BLKSIZE

memory constrained environments 16

options

1ADSTOP

at invocation 21

AMODE24

at invocation 21

options (*continued*)

AMODE31  
     at invocation 21  
 APROGMSG  
     setting 90  
 ASCII  
     at invocation 21  
 ASMLANGX  
     See ASMLANGX option  
 at invocation 28  
 AUDIT  
     setting 92  
 AUTOLOAD 186  
     at invocation 21  
 AUTOSIZE 60  
     at invocation 22  
 BCX  
     at invocation 22  
 BRIEF  
     setting 97  
 CKSUBCM  
     at invocation 22  
 CMDLOG 72, 141  
     at invocation 22, 29  
 CMPEXIT  
     at invocation 23  
     loading exit routing 217  
 COLORS  
     at invocation 23  
 COLOURS  
     at invocation 23  
 COMMAND 37, 39, 47  
     at invocation 23  
 COMPACT  
     setting 102  
     described 177  
     displaying 68  
 DMSO  
     at invocation 23  
 EXITEXEC 214  
     at invocation 24  
 FASTPATH 32, 33  
     at invocation 24  
 FULLQUAL 75, 228, 229  
     at invocation 24  
 HEXDISP  
     at invocation 24  
     showing displacements 229  
 HEXINPUT  
     at invocation 25  
 IDF Language Support  
     display 128  
 IMPMACRO  
     at invocation 25  
 INVPSW 178  
     at invocation 25

options (*continued*)

ISA  
     at invocation 25  
 LIBE  
     at invocation 25  
 LINE 52  
     at invocation 26  
 LSMDEBUG  
     at invocation 26  
 LUNAME  
     at invocation 26, 54  
 macro  
     examining from within 239  
     setting from 177  
 MACROLOG 141, 208  
     at invocation 26  
 MAJOR  
     setting 139  
 MODE 72  
     at invocation 26  
     changing value 237  
     checking value 237  
 MODMAP  
     at invocation 27  
 MSGID  
     interaction with CMDMSG 226  
     interaction with LASTMSG 234  
     setting 148  
 MSGMODE  
     setting 149  
 NOAUTOLD 186  
     at invocation 21  
 NOAUTOSZ 60  
     at invocation 22  
 NOBCX 64  
     at invocation 22  
 NODSECTS  
     at invocation 27  
 NOIMPMAC  
     at invocation 25  
 NOINVPSW 178  
     at invocation 25  
 NOMODMAP  
     at invocation 27  
 NOPROFIL  
     at invocation 28  
 NOSTOPNP 151, 185, 186  
     at invocation 29  
 NOSTOPST 185  
     at invocation 30  
 NOSVC97 5, 36  
     at invocation 30  
 NUCEXT 46  
     at invocation 27  
 OFFSET 153  
     at invocation 27

## Index

### options (*continued*)

OLDBREAK  
  at invocation 27  
PASSPGM  
  at invocation 28  
PATH 32, 63  
  at invocation 24  
PATHFILE 32, 33, 63  
  at invocation 24  
PROFILE 204  
  at invocation 28  
QWDUMP  
  at invocation 28  
RISK 138, 178, 236  
  at invocation 28  
RLOG 73, 169  
  at invocation 28  
ROWSTYLE  
  at invocation 29  
SAREGS  
  setting 171  
SBORDER  
  at invocation 29  
SCDACTIV  
  at invocation 29  
SELFNUCX 46, 47  
  at invocation 29  
SPACE  
  setting 184  
STOPNOP 151, 185, 186  
  at invocation 29  
STOPSTMT 185  
  at invocation 30  
SVC97 5, 36  
  at invocation 30  
SWAP 43, 52, 58, 189  
  at invocation 30  
SYSTEM  
  at invocation 30  
TRACEALL 138, 178, 236  
  at invocation 31  
TRANS 45  
  at invocation 31  
UNFTDUMP  
  at invocation 31  
OPTIONS command 128, 155  
ORDER command 59, 155  
OREGS command 156

## P

PA1 key 50  
PACK ASMLANGX option 254  
PACKED command 156  
parameter  
  variable  
    displaying list 156

parameter list  
  passed to IDF 19  
parameter list passed to IDF 240  
parameters  
  passing to CMS program 44  
  passing to TSO program 36  
  passing to VSE program 54  
PARMS command 156  
PASSPGM option  
  at invocation 28  
PATH option 32, 50, 63  
  at invocation 24  
PATHFILE option 32, 63  
  at invocation 24  
pattern matching a variable name 151  
PAUSE command 157  
PER 21  
  advantages and disadvantages of use 51  
  disabled 47  
  enabling 51  
  examining setting from within a macro 239  
  operating 61  
  performance impact 273  
PER command 157  
PF keys  
  commands invoked by 85  
  default settings 72  
  examining settings from within a macro 239  
  redefining 158  
  redefinition of 72  
  settings  
    displayed 158  
PFK command 8, 158  
PFKDISP command 158  
PFM ASMLANGX option 255  
PFT ASMLANGX option 255  
PLOCATES command 159  
pointer variable  
  displaying Located variables 159  
  extracting Located variables 240  
  obtaining Located variables 240  
preparation  
  assembly 14  
PRESERVE command 159  
preserving  
  IDF settings 159  
PREVIOUS command 160  
PROFILE macro  
  invocation option overrides setting in macro 36  
  loading module and symbols 135  
  loading target program with LIBE 133  
  loading target program with LOAD 134  
  passing options as invocation parameters 19, 20  
  setting MODE 237  
  setting PSWSTEAL breakpoints 163  
  writing 204

PROFILE option 204  
   at invocation 28  
 PROGCHK command 161  
 PROGCK command 161  
 program build  
   requirements  
     HLASM 14  
 program checks  
   passing to CMS 28  
   passing to MVS 28  
   passing to VSE 28  
 program debug  
   getting started 8  
 program preparation  
   getting started 8  
 programmed symbol sets  
   used by target program 52, 58  
 programmed symbol sets used by target program 43  
 PSW  
   changing from within a macro 178  
   modifying 62  
   obtaining contents from a macro 241  
   obtaining display of 62  
   stealing 53  
 PSW command 117  
 PSWSTEAL command 162, 225  
 publications  
   general 286  
   High Level Assembler 285  
   HLASM Toolkit 285  
   machine instructions 285  
   MVS 285

## Q

QQUIT command 165  
 QUALIFY command 164  
 QUIET ASMLANGX option 253  
 QUIET command 164  
 QUIETLY command 164  
 QUIT command 165  
 QWDUMP option  
   at invocation 28

## R

R0-R15 commands 170  
 R1, flag byte 44  
 railroad track format, how to read xiii—xv  
 RCQUIT command 165  
 Read Buffer command 43, 52, 58  
 REFRESH command 166  
 registers  
   Access  
     change contents from a macro 173  
     display 91  
     initial contents 32

registers (*continued*)  
   Access (*continued*)  
     modifying 62  
     obtaining contents from a macro 223  
     obtaining display of 62  
 AR  
   referring to in expressions 74  
 Control  
   modifying 62  
   obtaining display of 62, 103  
 Floating Point  
   initial contents 32  
 FPC  
   changing contents from a macro 116  
 FPR  
   changing contents from a macro 117  
   initial contents 32  
   modifying 62  
   obtaining contents from a macro 241  
   obtaining display of 62, 156, 167  
 GPR  
   changing contents from a macro 118  
   initial contents 31  
   modifying 62  
   monitoring 60  
   obtaining contents from a macro 241  
   obtaining display of 62, 167  
   referring to in expressions 74  
   monitoring 88  
     determining registers from a macro 242  
   not displayed 39, 47  
   obtaining display of 156  
 REGS command 167  
 REGSTOP  
   setting from within a macro 179  
 RegStops  
   availability of 51  
 REGSTOPS command 89  
 requirements  
   assembly 14  
   program build  
     HLASM 14  
 RESTORE command 167  
 restoring  
   IDF settings 167  
 RETRIEVE command 167  
 return codes  
   ASMLANGX 18  
   EXTRACT 222  
   passing at exit from IDF 165  
 REXX  
   commands available to 207  
   debugging CMS programs invoked by 49  
   debugging TSO programs invoked by 41  
   default ADDRESS 207  
   functions  
     debugging 6

## Index

- REXX (*continued*)
    - functions, debugging 6
    - macros 111, 130
    - variables 111, 130
  - RIGHT command 168
  - RISK option 138, 178, 236
    - at invocation 28
  - RLOG command 73, 168, 196
  - RLOG option 73, 169
  - ROWSTYLE option
    - at invocation 29
  - RUN command 169
  - RUNEXIT command 169
- S**
- SALIMIT command 170
  - SAREGS command 171
  - SAREGS option
    - setting 171
  - SAVE command 159
  - saving
    - IDF settings 159
  - SBORDER option
    - at invocation 29
  - SCDACTIV option
    - at invocation 29
  - screen
    - customization 122
  - scroll
    - backward a window 160
    - forward a window 152
  - SCROLL command 128
  - scrolling
    - array display 121
    - LSM Information window 121
    - status display 121
    - structure display 121
    - union display 121
    - variable display 121
  - search
    - limits of 171
    - memory for a string 171
  - SEARCH command 171
  - self-load offset
    - setting 172
  - SELFNUCX command 172
  - SELFNUCX offset
    - controlling start offset with SELFNUCX 172
    - obtaining from macro 243
    - PROFILE macro
      - setting 172
  - SELFNUCX option 37, 46, 47
    - at invocation 29
  - SEQ ASMLANGX option 255
  - SET ADSTOP command 173
  - SET AREG command 173
  - SET BREAK command 173
  - SET COMMAND command 174
  - SET EXITEXEC command 174, 214
    - issuing before CMPEXIT option 217
  - SET GLOBAL command 176
  - SET GLOBAL STEM command 175
  - SET ICOUNT command 176
  - SET MODULE command 141
  - SET OFFSET command 176
  - SET OPTION command 177
  - SET PSW command 178
  - SET REGSTOP command 179
  - SET SIZE command 179
  - setting file mode 141
  - setting qualified module 164
  - settings
    - IDF Language Support
      - display 128
  - SHOW command 179
  - simulating a program check 161
  - SIZE command 181
  - size of program
    - setting 179
  - skipped subroutines
    - examining from a macro 243
    - setting and clearing 183
  - SKIPSTEP command 34, 79, 151, 183
  - SKIPSTEPS
    - how to clear 69
  - source code
    - display
      - BOTH source and DISASM 119, 179
      - comments 119, 179
      - declarations 119, 179
      - DISASM only 119, 179
      - enabling 179
      - excluding 119
      - macro expansions 119, 179
      - positioning 94, 113, 131, 192
      - source line numbers 179
      - source only 119, 179
      - source statement numbers 179
    - locate string in 137
    - locating specific 111
    - search
      - forward 111, 137
      - ISPF editor style 111
      - reverse 111, 137
      - XEDIT style 137
  - source records
    - extraction 244
    - obtaining 244
  - SPACE command 184

- SPACE option
  - setting 184
- stack
  - IDF settings 159, 167
- stacked items xiv
- statement numbers
  - source code
    - display 179
- statement scope
  - extraction 242
  - obtaining 242
- status
  - display 128
    - scrolling 128
  - display scrolling 121
- STATUS command 129, 184
- status information
  - extraction 233
  - Global Storage 118
  - obtaining 233, 241
- STEM command 130
- STEP command 185
- STMTSTEP command 185
- STOKEY command 186
- STOPNOP option 151, 185, 186
  - at invocation 29
- STOPSTMT option 185
  - at invocation 30
- storage
  - allocation map
    - display 187
    - extraction 244
    - obtaining 244
  - displaying
    - in disassembly format 63, 107
    - in dump format 64, 109
  - examining from within a macro 235, 236
  - key 186
  - modifying
    - from a macro 137, 138
    - from a window 4, 63, 66
- storage areas
  - monitoring 88
- STOREMAP command 187
- string
  - locate 137
  - searching for 171
- structure
  - based 81, 188
  - data attributes
    - obtaining 245
  - data display 187
    - obtaining 245
  - display 128
    - detail 106, 139
    - intermediate components 106
    - levels visible 106, 139
  - structure (*continued*)
    - display (*continued*)
      - major component 139
      - scrolling 128
    - display scrolling 121
    - extraction 245
    - information
      - obtaining 245
- STRUCTURE command 187
- STXIT code
  - on VSE 56
- STXIT OC 57
- SUBSET
  - access to 46
- SUBSET command 189
- SUBSET, CMS
  - access to 46
- subtasks
  - on VSE 56
- SVC
  - obtaining trace status from macro 245
- SVC command 189
- SVC trapping
  - enabling and disabling from macro 189
- SVC97 option 5, 36
  - at invocation 30
- SWAP command 189
- SWAP option 43, 52, 58, 189
  - at invocation 30
- SYMBOL command 190
- symbolic dump 65
- symbols 245
  - dropping 109
  - user-defined 190
- synonyms 121
- syntax notation, description xiii—xv
- SYSTEM option
  - at invocation 30

## T

- task information
  - display 191
  - extraction 247
  - obtaining 247
- TASKS command 191
- terminal
  - device address 26
- TITLE command 191
- title text of window 191
- TOP command 192
- TRACEALL option 138, 178, 236
  - at invocation 31
- TRANS option 45
  - at invocation 31

## Index

Transient Area  
  programs, debugging 45  
TRIGGER LOAD command 192  
TSO  
  dataset conventions 35  
  DD conventions 35  
  IKJSCAN 37  
  programs, debugging 37  
TSO programs  
  debugging 35  
TSO TEST  
  CP option 37  
TSOEXEC 35, 38  
type attributes  
  display 193  
  extraction 247  
  variable  
    display 193  
    obtaining 247  
TYPE command 193

## U

unformatted dump 65  
UNFTDUMP option  
  at invocation 31  
union  
  based 81, 188  
  data display 187  
  display  
    detail 106, 139  
    intermediate components 106  
    levels visible 106, 139  
    major component 139  
  display scrolling 121  
UNION command 194  
UNTIL command 194  
UP command 160

## V

VALUE command 194  
VARIABLE 80  
  based 81, 82  
  data address  
    obtaining 250  
  data attributes  
    display 193  
    obtaining 247, 248, 249  
  data display 80, 195  
    obtaining 248, 249, 250  
  data location  
    obtaining 250  
  data value  
    obtaining 250  
  display 97, 102, 121, 128, 184  
  declarations 97, 102, 184

VARIABLE (*continued*)  
  display (*continued*)  
    minimal 102  
    scrolling 121, 128  
    single line 102  
  display scrolling 121  
  extraction 247, 248, 249, 250  
  information  
    obtaining 247, 248, 249, 250  
  locator  
    displaying Located variables 159  
    extracting Located variables 240  
    obtaining Located variables 240  
  names  
    displaying list 151  
    extracting list 238  
  optimized  
    alteration 100  
  parameter  
    displaying list 156  
  pointer  
    displaying Located variables 159  
    extracting Located variables 240  
    obtaining Located variables 240  
  type attributes  
    display 193  
    obtaining 247  
VARIABLE command 195  
variable data  
  format  
    bit variables 94  
    character variables 99  
    class 115  
    default 115  
    displaying 115  
    fixed variables 113  
    float variables 114  
    individual 115  
    inherited 115  
    packed decimal variables 156  
    Zoned decimal variables 200  
Variables  
  REXX  
    set by EXTRACT command 219  
VCHANGE command 196  
VERSION command 130, 196  
version of IDF  
  obtaining from macro 249  
versions supported 5  
VS command 197  
VSE  
  dataset conventions 54  
  programs  
    debugging 54  
VSE programs  
  debugging 54

VSEP command 197

## W

WATCH command 197

watchpoints 197

WHERE command 199

windows

Additional Floating-Point Registers window 61

opening and closing 89

AdStops window 60

opening and closing 88, 89

as target of command 71

Break window 61

opening and closing 95, 104

closing 101

controlling title text 191

Current Registers window 62, 167

Disassembly window 63, 107

Dump mode 64

Dump window 109

display previous data 93

examples 70

LSM information 187

LSM Information window 66, 91, 195

maximizing 140

Minimized Windows Viewer 67

minimizing on the screen 140

moving 144

moving to top of screen 155

Old Registers window 68, 156

opening 154

Options window 68

refreshing contents 166

scrolling left 132

scrolling right 168

selecting 71

sizing 181

Skipped Subroutines window 69

opening and closing 183

summary of types 59

Target Status 184

Target Status window 69

Window Specification 71

writing macros 207

## X

XA Exploitation

memory constrained environments 16

XEDEXIT command 200

XPATH command 131

## Z

ZONED command 200

---

## We'd Like to Hear from You

High Level Assembler for MVS® & VM & VSE  
Toolkit Feature  
Interactive Debug Facility User's Guide  
Release 4  
Publication No. GC26-8709-03

Please use one of the following ways to send us your comments about this book:

- Mail—Use the Readers' Comments form on the next page. If you are sending the form from a country other than the United States, give it to your local IBM branch office or IBM representative for mailing.
- Fax—Use the Readers' Comments form on the next page and fax it to this U.S. number: 800-426-7773.
- Electronic mail—Use one of the following network IDs:
  - IBMLink: HLASMPUB at STLV27
  - Internet: COMMENTS@VNET.IBM.COM

Be sure to include the following with your comments:

- Title and publication number of this book
- Your name, address, and telephone number if you would like a reply

Your comments should pertain only to the information in this book and the way the information is presented. To request additional publications, or to comment on other IBM information or the function of IBM products, please give your comments to your IBM representative or to your IBM authorized remarketer.

IBM may use or distribute your comments without obligation.

---

# Readers' Comments

**High Level Assembler for MVS® & VM & VSE  
Toolkit Feature  
Interactive Debug Facility User's Guide  
Release 4**

**Publication No. GC26-8709-03**

How satisfied are you with the information in this book?

	Very Satisfied	Satisfied	Neutral	Dissatisfied	Very Dissatisfied
Technically accurate	<input type="checkbox"/>	<input type="checkbox"/>	<input type="checkbox"/>	<input type="checkbox"/>	<input type="checkbox"/>
Complete	<input type="checkbox"/>	<input type="checkbox"/>	<input type="checkbox"/>	<input type="checkbox"/>	<input type="checkbox"/>
Easy to find	<input type="checkbox"/>	<input type="checkbox"/>	<input type="checkbox"/>	<input type="checkbox"/>	<input type="checkbox"/>
Easy to understand	<input type="checkbox"/>	<input type="checkbox"/>	<input type="checkbox"/>	<input type="checkbox"/>	<input type="checkbox"/>
Well organized	<input type="checkbox"/>	<input type="checkbox"/>	<input type="checkbox"/>	<input type="checkbox"/>	<input type="checkbox"/>
Applicable to your tasks	<input type="checkbox"/>	<input type="checkbox"/>	<input type="checkbox"/>	<input type="checkbox"/>	<input type="checkbox"/>
Grammatically correct and consistent	<input type="checkbox"/>	<input type="checkbox"/>	<input type="checkbox"/>	<input type="checkbox"/>	<input type="checkbox"/>
Graphically well designed	<input type="checkbox"/>	<input type="checkbox"/>	<input type="checkbox"/>	<input type="checkbox"/>	<input type="checkbox"/>
Overall satisfaction	<input type="checkbox"/>	<input type="checkbox"/>	<input type="checkbox"/>	<input type="checkbox"/>	<input type="checkbox"/>

Please tell us how we can improve this book:

May we contact you to discuss your comments?  Yes  No

\_\_\_\_\_  
Name

\_\_\_\_\_  
Address

\_\_\_\_\_  
Company or Organization

\_\_\_\_\_  
Phone No.



Fold and Tape

Please do not staple

Fold and Tape



NO POSTAGE  
NECESSARY  
IF MAILED IN THE  
UNITED STATES

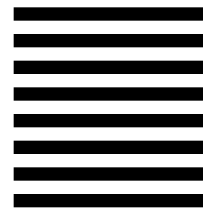

# BUSINESS REPLY MAIL

FIRST-CLASS MAIL PERMIT NO. 40 ARMONK, NEW YORK

POSTAGE WILL BE PAID BY ADDRESSEE

Department J58  
International Business Machines Corporation  
PO BOX 49023  
SAN JOSE CA 95161-9945



Fold and Tape

Please do not staple

Fold and Tape





Program Number: 5696-234



Printed in the United States of America  
on recycled paper containing 10%  
recovered post-consumer fiber.

#### **High Level Assembler Publications**

SC26-4941 *HLASM Programmer's Guide.*  
GC26-4943 *HLASM General Information.*  
GC26-4944 *HLASM Licensed Program Specifications.*  
SC26-4940 *HLASM Language Reference.*  
SC26-3494 *HLASM Installation and Customization Guide.*

---

#### **High Level Assembler Toolkit Feature Publications**

GC26-8709 *HLASM Toolkit Feature Interactive Debug Facility User's Guide.*  
GC26-8710 *HLASM Toolkit Feature User's Guide.*  
GC26-8711 *HLASM Toolkit Feature Installation Guide.*  
GC26-8712 *HLASM Toolkit Feature Debug Reference Summary.*

GC26-8709-03





HLASM

IDF User's Guide

*Release 4*